



18681 Lake Drive East
Chanhassen, MN 55317
952-607-6512
www.rpbcwd.org

Riley Purgatory Bluff Creek Watershed District Permit Application Review

Permit No: 2024-013

Considered at Board of Managers Meeting: May 8, 2024

Received complete: April 8, 2024

Applicant: City of Chanhassen

Representative: Kimley Horn – Adam Tjaden

Project: The applicant proposes a combination of street reconstruction and rehabilitation for the roadways in the Chan View neighborhood. Stormwater management will be provided by a regional reuse system, four biofiltration basins, two rain gardens, and an existing manufactured treatment device (EcoStorm 3) to provide volume control, water quality, and rate control.

Location: South of Santa Fe Trail, north of Chan View, west of Laredo Drive and east of Great Plains Boulevard in Chanhassen, MN.

Reviewer: Scott Sobiech, P.E., Barr Engineering Co.

Potential Board Variance Action

Manager _____ moved and Manager _____ seconded adoption of the following resolution based on the permit report that follows, the presentation of the matter at the May 8, 2024, meeting of the managers and the managers' findings, as well as the factual findings in the permit report that follows:

Resolved that the variance requests for Permit 2024-013 from compliance with Rule J, subsection 3.6b and the need to provide stormwater management within the permit term are approved, based on the facts and analysis provided by the RPBCWD engineer below and placed in the record at the May 8, 2024 meeting of the managers, and the managers' findings in the record of the May 8 meeting, and subject to the following conditions: 1. [CONDITION(S)]

Proposed Board Action

Manager _____ moved and Manager _____ seconded adoption of the following resolutions based on the permit report that follows and the presentation of the matter at the May 4, 2022 meeting of the managers:

Resolved that the application for Permit 2024-013 is approved, subject to the conditions and stipulations set forth in the Recommendations section of the attached report;

Resolved that on determination by the RPBCWD administrator that the conditions of approval of the permit have been affirmatively resolved, the RPBCWD president or administrator is authorized and directed to sign and deliver to the applicant, Permit 2024-013 on behalf of RPBCWD.

Upon vote, the resolutions were adopted, _____ [VOTE TALLY].

Applicable Rule Conformance Summary

Rule	Issue	Conforms to Rule?	Comments	
C	Erosion Control Plan	See comment.	See rule-specific permit condition C1 related to providing name and contact information for the individual responsible for erosion control.	
J	Stormwater Management	Rate	Yes	
		Volume	See Comment	See stipulation #5 related in infiltration testing during construction.
		Water Quality	See Comment	See Rule Specific Permit Condition J1 related to providing updated plans
		Low Floor Elev.	No	See Rule K variance request
		Maintenance	See Comment	See Rule Specific Permit Condition J2 and J3 related to maintenance agreement execution
		Chloride Management	See Comment	See stipulation #6 related in providing a chloride management plan prior to close-out.
		Wetland Protection	N/A	
K	Variances and Exceptions	See comment.	See variance request related to low floor elevation and timing of stormwater management construction.	
L	Permit Fee	N/A	Governmental Entity	
M	Financial Assurance	N/A	Governmental Entity	

Background

The applicant proposes a combination of street reconstruction and rehabilitation for roughly three miles of roadways in the Chan View neighborhood located the northern portion of the Rice Marsh Lake watershed and southwestern portion of the Lotus Lake watershed. The project site is bounded by Santa Fe Trail to the north, Chan View to the south, Laredo Drive to the east (no work on Laredo Drive as part of this project), and Great Plains Boulevard to the west as shown in the adjacent figure.

Stormwater management will be provided by a regional reuse system, four biofiltration basins, two rain gardens, and an existing manufactured treatment device (EcoStorm 3) to provide volume control,

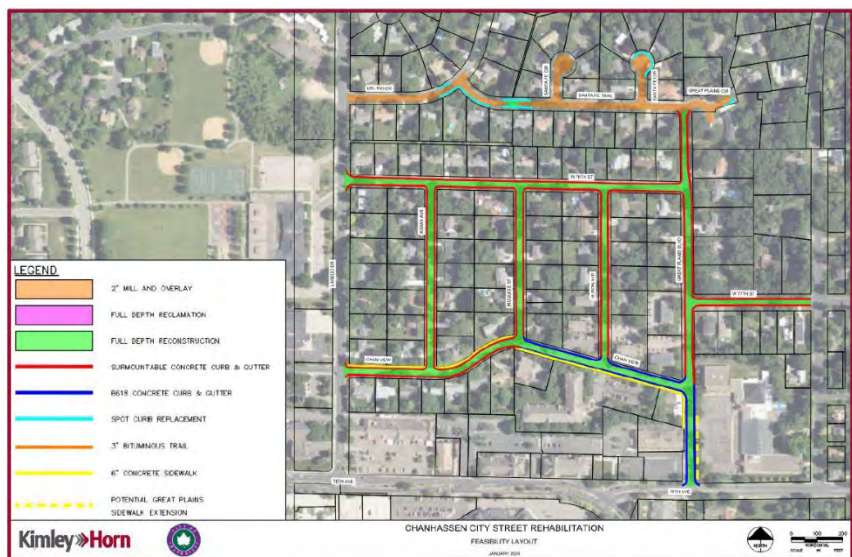

water quality, and rate control. Under existing and proposed conditions, the existing manufactured treatment device (EcoStorm 3) will treat runoff in the northwest corner of the site from Del Rio Drive. The water resources within the project site or downgradient of the proposed activities are summarized in Table 1.

Table 1 Water resource impacted by project

Water Resource	Projected resource impacts
Lotus Lake	Lotus Lake (public water basin 10000600) receives discharge from the site

Relevant project site information is provided in Table 2.

Table 2 Relevant Project Information

	Total Project
Total Site Area (acres)	8.33
Existing Site Impervious (acres)	6.23
Post Construction Site Impervious (acres)	6.41
New (Increase) in Site Impervious Area (acres)	0.18
Disturbed impervious surface (acres)	4.56
Exempt Rehabilitated Impervious Surface and sidewalks (acres)	1.85
Regulated Impervious Surface (acres)	4.56
Total Disturbed Area (acres)	7.0

The following materials were reviewed in support of the permit request:

1. Permit application dated March 8, 2024 (Notified applicant on March 18, 2024 that submittal was incomplete, materials completing the application received April 8, 2024)
2. Galpin Stormwater Management Report dated March 8, 2024 (revised March 29, 2020)
3. Downtown Chanhassen Regional Stormwater Framework dated March 2024 (Revised April 2024)
4. Construction Drawings (188 sheets) dated February 29, 2024
5. Geotechnical/Pavement Evaluation Report by Bruan Intertec dated January 31, 2024 (attached to SWM Report)
6. Double ring infiltrometer testing results dated January 4, 2024 (attached to SWM Report)
7. Electronic HydroCAD models for existing and proposed conditions received March 9, 2024 (revised March 29, 2024 and April 19, 2024)
8. Electronic MIDS modeling received March 9, 2024 (revised April 19, 2024)
9. Residential Rain Garden locations and Representative MIDS modeling received April 19, 2024
10. Electronic SHSAM modeling received April 10, 2024
11. Variance request dated April 11, 2024
12. Response to Comments from Kimley Horn dated March 29, 2024
13. Response to Comments from Kimley Horn dated April 19, 2024

Rule Specific Permit Conditions

Rule C: Erosion Prevention and Sediment Control

Because the project will involve 7.0 acres of land-disturbing activity, the project must conform to the requirements set forth by the RPBCWD Erosion Prevention and Sediment Control rule (Rule C, Subsection 2.1a).

The erosion control plans prepared by Kimley Horn includes installation of silt fence, sediment control logs, stabilized construction entrances, inspection, staging areas, riprap at flared ends, placement of a minimum of 6 inches of topsoil with a minimum 5% organic matter, decompaction of areas compacted during construction, and retention of native topsoil onsite to the greatest extent possible. To conform to RPBCWD Rule C requirements, the following revisions are needed:

- C1. The Applicant must provide the name, address and phone number of the individual who will remain liable to the District for performance under this rule and maintenance of erosion and sediment-control measures from the time the permitted activities commence until vegetative cover is established.

Rule J: Stormwater Management

Because the project will alter more than 7.0 acres of surface area, conformance with RPBCWD's Stormwater Management Rule (Rule J) is required.

The project entails construction and reconstruction that altogether amounts to 6.41 acres of linear impervious surface entirely within linear corridors and independent of a larger development or redevelopment; therefore, stormwater management for this linear project must be provided in accordance with the criteria of Subsection 3.2 (Rule J, Subsection 2.4). The 6.41 acres of impervious surface includes 1.5 acres of pavement rehabilitation and sidewalks less than 10 feet wide and bordered downgradient by pervious surface which are exempt from RPBCWD's stormwater management rule (Rule J, Subsection 2.2c and 2.2d). Therefore, the requirements of Rule J apply to 4.91 acres of proposed new and reconstructed impervious surface within the site.

Stormwater management will be provided by a regional reuse system, four biofiltration basins (two of which have elevated driantile to promote infiltration), two rain gardens, and an existing manufactured treatment device (EcoStorm 3) to provide volume control, water quality, and rate control.

Rate Control

In order to meet the rate control criteria listed in Subsection 3.1.a, the 2-, 10-, and 100-year post development peak runoff rates must be equal to or less than the existing discharge rates at all locations where stormwater leaves the site.

The applicant used HydroCAD to simulate runoff rates for pre- and post-development conditions for the 2-, 10-, and 100-year frequency storm events using a nested rainfall distribution, and a 100-year frequency, 10-

day snowmelt event. The existing and proposed 2-, 10-, and 100-year frequency discharges from the site are summarized in Table 3. Except for the slight increased discharge leaving the site at RM 3-6 Laredo, the proposed project is in conformance with RPBCWD Rule J, Subsection 3.1.a. Because the proposed discharge increase leaving the site at RM 3-6 Laredo is less than 0.05 cubic feet per second (cfs) which is within the accuracy of the modeling, the RPBCWD engineer finds the proposed project conforms with RPBCWD Rule J, Subsection 3.1.a.

Table 3. Rate control summary:

Modeled Discharge Location ¹	2-Year Discharge (cfs)		10-Year Discharge (cfs)		100-Year Discharge (cfs)		10-Day Snowmelt (cfs)	
	Ex	Prop	Ex	Prop	Ex	Prop	Ex	Prop
RM 3-6P	18.5	17.8	29.9	28.1	56.0	54.6	3.0	3.0
RM 3-6 Laredo	0.3	0.3	0.44	0.48	0.82	0.86	<0.1	<0.1
LL 6-2 GP	4.0	3.0	6.7	6.3	12.8	12.4	0.6	0.6
LL 6-2 76th	1.2	1.2	1.9	1.9	3.6	3.6	0.2	0.2
LL 1-25 SF	3.3	1.7	5.4	3.6	10.4	7.9	0.5	0.2
LL 1-25 77th	2.0	2.0	3.4	3.4	6.5	6.5	0.3	0.3

¹ LL indicates discharges toward Lotus Lake and RM indicates discharges to a regional wet detention pond to be used for rainwater harvest. Stormwater leaving the regional wet detention pond is conveyed to Rice Marsh Lake.

Volume Abstraction

Subsection 3.2c of Rule J requires the abstraction onsite of the larger of 0.55 inches of runoff from the new and fully reconstructed linear impervious surfaces or 1.1 inches from the net increase in linear impervious area. In this case 0.55 inches of runoff from the new and fully reconstructed impervious surfaces – 9,101 cubic feet – is the larger volume. An abstraction volume of 9,101 cubic feet is required from the 4.56 acres of new and reconstructed linear impervious surface on the site. The applicant is proposing four biofiltration basins (two of which have elevated drintile to promote infiltration), and two rain gardens to provide the required abstraction volume. Pretreatment for the biofiltration basins and rain gardens will be provided using an engineered settling bay constructed with splash blocks.

Soil boring information collected by Braun Intertec at 42 locations across the site indicate the soils are predominately sandy lean clay under varying depth of lean clay fill. The subsurface investigation information summarized in the table below supports a determination that groundwater is at least 3 feet below the bottom of the proposed biofiltration stormwater facilities (Rule J, Subsection 3.1.b.2.a).

Proposed BMP	Nearest Subsurface Investigation	Boring is within footprint?	Groundwater Elevation (feet)	BMP Bottom Elevation (feet)	Separation (feet)
WT-RG-1	P-3	Yes	Redoximorphic conditions observed at el. 984.3 ft	987.5	3.2
GP- RG-1	B-4	No - In Street Adjacent to BMP	No groundwater observed at boring bottom (approx. el 977 ft)	987	10
GP- RG-2	B-4	No - In Street Adjacent to BMP	No groundwater observed at boring bottom (approx. el 977 ft)	984.5	7.5
SF- RG-1	P-5	No - In Street Adjacent to BMP	Redoximorphic conditions observed at el. 975 ft	978.4	3.4

Braun Intertec performed 5 double ring infiltrometer tests at the site in January 2024. The testing revealed infiltration rates of 0.0-1.43 in/hr at the proposed biofiltration basins. Four of the five tests yielded no infiltration but were collected when ground temperatures were below freezing. The fifth test displayed atypical results of increasing infiltration over time and was also collect with ground temperatures at freezing. While these results suggest the infiltration capacity of the underlying soils on this site is limited and are suspect due to the temperature conditions during testing, the close proximity of existing homes with low floor below the proposed basin bottoms present additional restrictions for infiltrating stormwater at WT-RG-1 and SF-RG-1.

The engineer concurs that the clay soils have limited infiltration capacity, there are areas of seasonally high groundwater indicated by redoximorphic soils, and the close proximity of existing homes indicate the site is restricted and stormwater runoff volume can be managed in accordance with subsection 3.3 of Rule J. For restricted sites, subsection 3.3 of Rule J requires rate control in accordance with subsection 3.1.a and that abstraction and water quality protection be provided in accordance with the following sequence:

- (a) Abstraction of 0.55 inches of runoff from site impervious surface determined in accordance with paragraphs 2.3, 3.1 or 3.2, as applicable, and treatment of all runoff to the standard in paragraph 3.1c; or
- (b) Abstraction of runoff onsite to the maximum extent practicable and treatment of all runoff to the standard in paragraph 3.1c; or
- (c) Off-site abstraction and treatment in the watershed to the standards in paragraph 3.1b and 3.1c.

Because the project area is primarily clay soils with limited to no infiltration capacity, there are areas of seasonally high groundwater indicated by redoximorphic soils, and the close proximity of existing homes with low floors lower than the indicated seasonally high ground water, the engineer concurs the standard in Subsection 3.3a of Rule J cannot practicably be achieved from runoff from regulated impervious and the Applicant is providing abstraction of 399 cubic feet of runoff from the regulated impervious surface, which

the engineer finds to be the maximum extent practicable (see Table 4) and the proposed activity conforms to Rule J, Subsection 3.3b.

Table 4. Volume abstraction summary

Subwatershed	Required Abstraction Depth (inches)	Required Abstraction Volume (cubic feet)	Provided Abstraction Depth (cubic feet)	Provided Abstraction Volume (cubic feet)
Lotus Lake	0.55	1,796	0.11	373
Rice Marsh Lake	0.55	7,305	<0.01	36

Because of the biofiltration BMP locations within the boulevard and the cold temperatures during the infiltration testing, the applicant was unable to excavate to the required depths to conduct infiltration tests at the BMP bottoms prior to construction. The engineer concurs with the applicant’s design infiltration rates of 0.06 inches per hour based on the guidelines provided in the Mn Stormwater Manual. Based on the design infiltration rate, the engineer concurs that the proposed infiltration systems will draw down within 48 hours (Rule J, subsection 3.1b.3). Per Rule J, Subsection 3.1.b.2.c measured infiltration capacity of the soils at the bottom of the infiltration systems must be provided. The applicant must submit documentation verifying the infiltration capacity of the soils and that the volume control capacity is calculated using the measured infiltration rate at biofiltration basin GP- RG-1 and GP- RG-2. If infiltration capacity is less than 0.06 inches per hour, or there is inadequate separation to groundwater, design modifications to achieve compliance with RPBCWD requirements will need to be submitted (in the form of an application for a permit modification or new permit).

Water Quality Management

Subsection 3.1.c of Rule J (made applicable by 3.2c) requires the Applicant to provide for at least 60 percent annual removal efficiency for total phosphorus (TP), and at least 90 percent annual removal efficiency for total suspended solids (TSS) onsite or within the same subwatershed as the land-disturbing activities, as well as no net increase in pollutant loading from existing conditions. The Applicant is proposing the following stormwater management facilities to treat runoff from the site:

1. Lotus Lake Subwatershed
 - a. Biofiltration Basin GP-1
 - b. Biofiltration Basin GP-2
 - c. Biofiltration Basin SF-1
 - d. Two Rain Gardens
 - e. Existing manufactured treatment device (EcoStorm 3)
2. Rice Marsh Lake Subwatershed
 - a. Biofiltration Basin WT-1
 - b. Regional Reuse System within the same subwatershed

Because the city proposes to use an off-site regional reuse system to provide water quality within the same subwatershed for the portion of the project site within the Rice Marsh Lake subwatershed, the applicant provided the Downtown Chanhassen Regional Stormwater Framework report to support the analysis. (This is the same analysis framework discussed at the Board of Managers January 25, 2024 workshop.)

Downtown Chanhassen Regional Stormwater Framework outlines the city's use of a regional reuse system to provide abstraction beyond that required for compliance with subsection 3.3b discussed above and water quality treatment for the Chan View Street Reconstruction (RPBCWD Permit 2024-013), Chanhassen Civic Campus reconstruction (RPBCWD Permit 2024-023, currently under review) and Market Boulevard improvements (future application, expected 2025). The following image shows the areas associated with the above referenced permits are tributary area to the proposed regional reuse system.

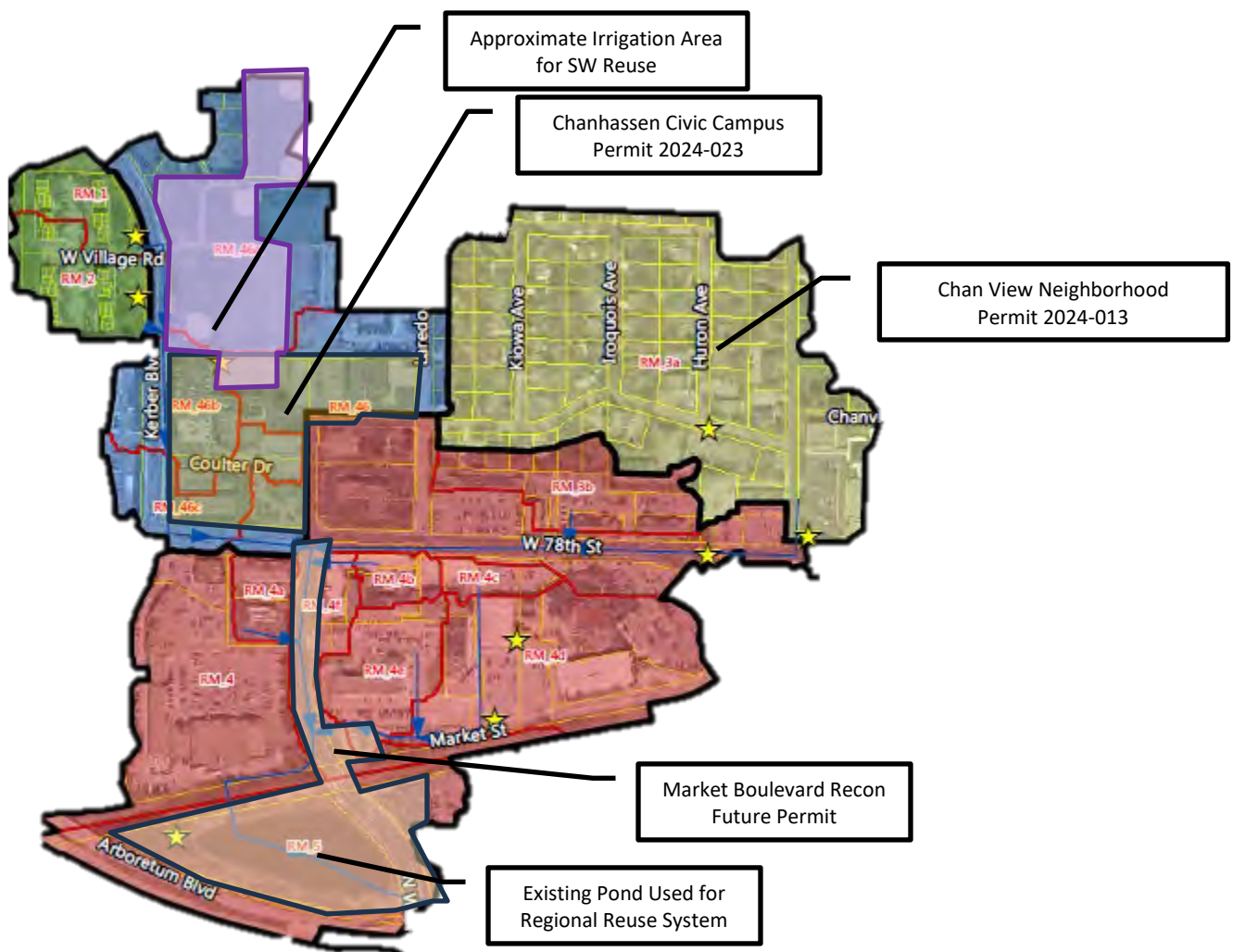

To qualify for approval, a stormwater-management plan must provide for compliance with RPBCWD stormwater-management criteria in conjunction with implementation of the permitted work. Here, the city plans to construct the reuse system with the Market Boulevard improvements project anticipated for 2025,

while the proposed road redevelopment proceeds in 2024 with some site restoration in 2025. The regional reuse system will likely not be implemented prior to completion of the work that is the subject of permit application 2024-013, which represents a shortfall from compliance with all relevant criteria, The applicant is requesting a variance to allow delayed compliance with the RPBCWD stormwater requirements. (Because the regional reuse system is intended to support stormwater compliance with select parcels and right of way projects rather than all parcels within the study region, the regional stormwater management approach in Rule J, subsection 4 is not applicable.)

The applicant provided proof of concept drawings demonstrating that the **stormwater for reuse** from the roads proposed to be reconstructed under the project would be collected in the existing stormwater pond located in the NW quadrant of Highway 5 and Market Boulevard. The reuse water would be pumped under Market Boulevard right of way to irrigate the existing ballfields located north of Chanhassen City Hall, the planned Chanhassen Civic Campus, and potentially the boulevards along Market Boulevard (see below image showing irrigation areas).

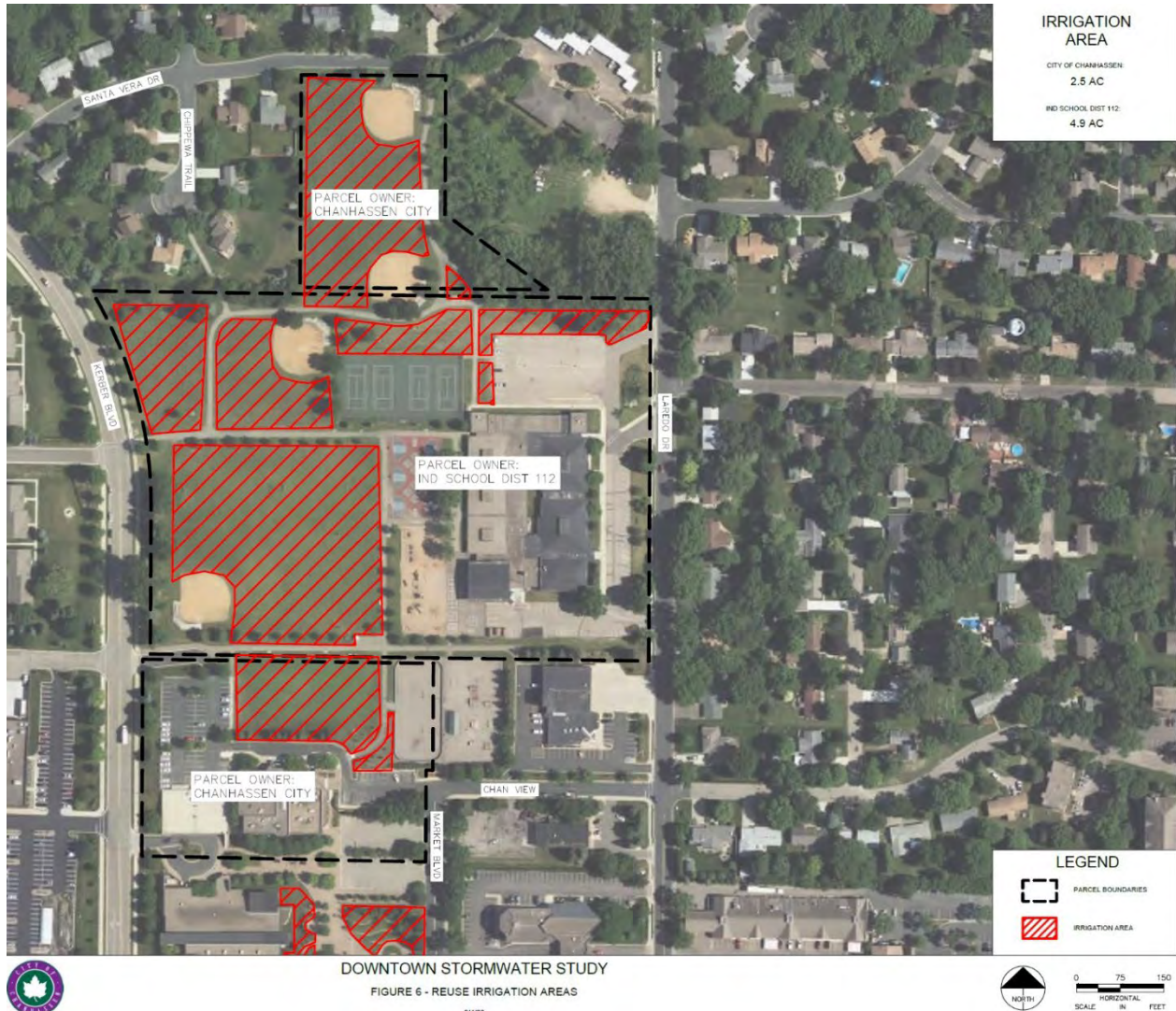

The applicant submitted 18 Modified Philip & Dunne(MPD) infiltration test result collected within the proposed irrigation areas to support the determination of the selected irrigation rate. The testing results indicate the infiltration rates of the surface soils range between 0.006 inches per hour to 16.1 inches per hour with an average rate of 1.71 inches per hour, which is indicative of a sandy soil. Seven of the 18 tests yielded no viable results using the MPD methodology and were excluded from the average. Reviewing the data collected at these 7 locations indicate the water level in the MPD unit typically dropped less than 0.24-2.96 cm over a roughly 3 hour duration, suggesting a lower infiltration rate. The engineer concurs with the applicant use of the MIDS model to estimate the pollutant reduction by irrigating the areas shown on the above image. Table 5 summarizes how the irrigation rate influences the pollutant reduction provided by the proposed reuse system.

Table 5. Influence of Irrigation Rate on Pollutant Reduction

Irrigation (inches)	Abstraction Volume (cubic feet)	TSS (lbs/yr)	TP (pbs/yr)
1.0	19,809	1,571	8.6
1.65	33,595	2,784	15.3
2.0	40,992	3,230	17.8

The applicant intends to reuse as much water as the conditions will allow while maintaining the areas in useable condition and requested approval of a 1.65 inch per week irrigation rate based on surface infiltration testing in the irrigation areas. The MIDS model estimates abstraction volume based on the amount of water that is used for irrigation over a three-day period (timeframe is the typical time between rainfall event in Minneapolis). Rather than irrigating 0.22 inches three times per week has suggested by the MIDS calculator, the applicant will need to irrigate an equivalent of 0.37 inches three times per week to maximize the abstraction volume provided by the system. Because of the infiltration testing conducted in the irrigation area, the engineer concurs with the use of a 1.65 inch per week irrigation rate to produce an available abstraction volume of 33,595 cubic feet and provide 15.3 pounds per year of total phosphorus reduction and 2,784 pounds per year of total suspended solids reduction. Because the required pollutant reductions for the regulated loads in the Rice Marsh Lake subwatershed (see Table 6) are less than the total produced by the reuse system, there may be excess pollutant reduction available for the applicant to use to demonstrate compliance for other permit applications (depending on actual irrigation rates achieved). If the monitored irrigation rates are less than 1.65 inches per week, design modifications to demonstrate compliance with RPBCWD requirements will need to be submitted to RPBCWD for review and approval in the form of a permit modification. Application of any extra pollutant reduction or volume abstraction used on other permits by this application will be analyzed under a separate permit application. Approval of permit 2024-013 by the Board of Managers does not constitute future approval of other permits.

MIDS water quality models and a SHSAM models were developed to estimate the TP and TSS loading from the watersheds and the removal capacity of the proposed BMPs. The results of this modeling are summarized in Table 6 and Table 7 below. The results show the proposed project will remove sufficient TSS and TP to achieve an overall pollutant reduction in accordance with the required annual removals (Rule J, Subsection 3.2c).

Table 6. Annual TSS and TP removal summary:

Subwatershed	Pollutant of Interest	Regulated Site Loading (lbs/yr)	Required Load Removal (lbs/yr) ¹	Provided Load Reduction (lbs/yr)
Lotus Lake	Total Suspended Solids (TSS)	351	316 (90%)	324 (92.3%)
	Total Phosphorus (TP)	1.93	1.16 (60%)	1.2 (62.2%)
Rice Marsh Lake ²	Total Suspended Solids (TSS)	1,340	1,206 (90%)	1,206 (90%)
	Total Phosphorus (TP)	7.38	4.43 (60%)	4.43 (60%)

¹Required load reduction is calculated based on the criteria in Rule J, Subsection 3.1c and the new and reconstructed impervious area site loading.

²Pollutant removals reflect the proposed BMPs only and exclude the treatment provided by the existing regional pond used to collect runoff for reuse.

Table 7. Summary of net change in TSS and TP leaving the site

Subwatershed	Pollutant of Interest	Existing Loading (lbs/yr)	Proposed Load after Treatment (lbs/yr)	Change (lbs/yr)
Lotus Lake	Total Suspended Solids (TSS)	349	27	-322
	Total Phosphorus (TP)	1.92	0.73	-1.19
Rice Marsh Lake ¹	Total Suspended Solids (TSS)	1,328	134	-1,194
	Total Phosphorus (TP)	7.31	2.95	-4.36

¹Pollutant removals reflect the proposed BMPs only and exclude the treatment provided by the existing regional pond and the enhanced removals that could occur by increased detention resulting from water withdrawals from the pond for irrigation purposes.

Because the final layout and configuration of two proposed rain gardens used to comply with RPBCWD criteria in the Lotus Lake watershed are being coordinated with the adjacent land owners through the city's rain garden initiative program, the applicant will need to provide final details during construction confirming the design is consistent with RPBCWD approvals (i.e, pollutant reductions and low floor separation). Because the proposed stormwater reuse system requires consistent use at a specified rate to meet District water quality requirements via abstractions, performance monitoring for the site will be required to ensure that the project provides the proposed volume abstraction. While the models were updated to reflect design revisions during the review process, to conform to RPBCWD Rule J requirements, the following revisions are needed:

- J1. The applicant must provide updated drawings to ensure the proposed stormwater facilities are constructed in a manner consistent with the submitted modeling.
- J2. The maintenance and operations agreement must also include a stormwater reuse monitoring and reporting plan that includes protection of the greenspace to be irrigated and metering of the volume of reuse, as well as maintenance specifics provided by the manufacturer(s) or installer(s) for the proprietary system.

Low floor Elevation

No structure may be constructed or reconstructed such that its lowest floor elevation is less than 2 feet above the 100-year event flood elevation according to Rule J, Subsection 3.6. In addition, a stormwater-management facility must be constructed at an elevation that ensures that no adjacent habitable building will be brought into noncompliance with a standard in this subsection 3.6. Because the project does not propose to construct or reconstruct structures that have low-floor elevations, subsection 3.6a does not

impose requirement on the project. However, the project will construct stormwater management facilities in proximity to existing habitable structures. The low floor elevations of the proposed houses and the 100-year high water elevation of the biofiltration basins are summarized in

Table 8. Because the low floor elevations of the existing structures are below the 100-year high water elevation of the adjacent stormwater facility, an alternative low floor analysis was conducted as outlined in Rule J, Appendix J.1 – Low-Floor Elevation Assessment. The results of the low floor analysis using Appendix J1 Plot 2: Minimum Depth to Water Table for No Further Evaluation is summarized in

Table 8. The results demonstrate the provided separation is greater than the minimum required, thus meeting the habitable structure requirements in Rule J, Subsection 3.6 except for the structures at 502 76th street and 7554 Great Plains Blvd, which the applicant is requesting a variance from the low floor criteria. (see Rule K analysis below)

Table 8. Low Floor Evaluation of Existing Structures

Structure Address	Stormwater Facility	100-year Event Flood Elevation of Feature (feet)	Lowest Floor Elevation of Building (feet)	Freeboard Provided (feet)	Distance from Building to Adj. Facility (ft)	Seasonal Water Table Elevation (ft)	Minimum Allowable Depth to Water Table (ft)	Provided Depth from Low Floor Elevation to Water Table (ft)
502 76th St.	WT-RG-1	990.58	984.2	-6.38	15	984	6	0.2
400 76th St.	GP-RG-1	990.71	986	-4.71	70	977	2	9
7601 Great Plains Blvd.	GP-RG-1	990.71	986.2	-4.51	100	977	1	9.2
401 Santa Fe Tr.	GP-RG-2	988.37	982	-6.37	65	977	2	5
7561 Great Plains Blvd.	GP-RG-2	988.37	983	-5.37	135	977	0.5	6
7554 Great Plains Blvd.	SF-RG-1	982.44	975.6	-6.84	80	975	1.6	0.6
400 Santa Fe Tr.	SF-RG-1	982.44	979.5	-2.94	135	975	0.5	4.5

Maintenance

Subsection 3.7 of Rule J requires the submission of maintenance plan. All stormwater management structures and facilities must be designed for maintenance access and properly maintained in perpetuity to assure that they continue to function as designed.

- J3. Because the applicant proposes reliance on irrigating greenspace on ISD 112 property, as part of the maintenance and operating agreement the applicant must provide information demonstrating the necessary property rights to use the greenspace into perpetuity for irrigation.
- J4. Permit applicant must provide a draft maintenance, inspection, and operating plan for review and approval by RPBCWD. As a public entity, the city of Chanhassen may comply with this requirement by entering into a maintenance agreement with the RPBCWD. The agreement must also include a

stormwater reuse monitoring and reporting plan that includes protection of the greenspace to be irrigated and metering of the volume of reuse.

Chloride Management

Subsection 3.8 of Rule J requires the submission of chloride management plan that designates the individual authorized to implement the chloride management plan and the MPCA-certified salt applicator engaged in implementing the plan. To close out the permit, Permit applicant must provide a chloride management plan that designates the individual authorized to implement the chloride management plan.

Wetland Protection

Because the proposed activities discharge to Lotus Lake and a downstream stormwater pond, Rule J, subsection 3.10 does not impose requirements on the project.

Rule K: Variances and Exceptions

The applicant requested the following two variances from the Rule J.

- Subsection 3.6b for the placement of a stormwater management facility.
- Allowing the stormwater management compliance to be deferred until the Market Boulevard project occurs in 2025, likely after the close-out of this permit 2024-013.

The attached variance request letter submitted on behalf of the applicant cites several facts related to the development in support of the request. Rule K requires the Board of Managers to find that because of unique conditions inherent to the subject property the application of rule provisions will impose a practical difficulty on the Applicant. Assessment of practical difficulty is conducted against the following criteria:

1. how substantial the variation is from the rule provision;
2. the effect of the variance on government services;
3. whether the variance will substantially change the character of or cause material adverse effect to water resources, flood levels, drainage or the general welfare in the District, or be a substantial detriment to neighboring properties;
4. whether the practical difficulty can be alleviated by a technically and economically feasible method other than a variance. Economic hardship alone may not serve as grounds for issuing a variance if any reasonable use of the property exists under the terms of the District rules;
5. how the practical difficulty occurred, including whether the landowner, the landowner's agent or representative, or a contractor, created the need for the variance; and
6. in light of all of the above factors, whether allowing the variance will serve the interests of justice.

It is the applicant's obligation to address these criteria to support a variance request (see attached variance memo). Following is the RPBCWD engineer's assessment of information received relevant to the applicant's variance requests.

Variance Request #1

The applicant requested a variance from the requirements of subsection 3.6b of the stormwater management rule (Rule J) which states stormwater-management facility must be constructed at an elevation that ensures that no adjacent habitable building will be brought into noncompliance with the low

floor elevation criteria. For purposes of the Board of Managers’ consideration, the following factors were analyzed based on Rule K.

- The applicant is proposing to construct two biofiltration basins (WT-RG-1 and SF-RG-1) on city property or within right of way to provide rate control at the site boundaries and water quality treatment of runoff prior to discharging downstream. The proposed location of these two basins results in the low floor of the structures at 502 76th St. and 7554 Great Plains Blvd. to be in noncompliance with subsection 3.6b, the freeboard criteria, as summarized below.

Structure Address	Stormwater Facility	100-year Event Flood Elevation of Feature (feet)	Lowest Floor Elevation of Building (feet)	Freeboard Provided (feet)	Distance from Building to Adj. Facility (ft)	Seasonal Water Table Elevation ¹ (ft)	Minimum Allowable Depth to Water Table (ft)	Provided Depth from Low Floor Elevation to Water Table (ft)
502 76th St.	WT-RG-1	990.58	984.2	-6.38	15	984	6	0.2
7554 Great Plains Blvd.	SF-RG-1	982.44	975.6	-6.84	80	975	1.6	0.6

¹ Groundwater was not observed in the borings so the evidence of redoximorphic soils conditions was used to determine the seasonal high groundwater elevation.

- With regard to variance criteria 2 and 3 – Because the proposed project will reduce the site discharge and pollutant loading leaving the site relative to existing conditions, as discussed in the Rule J analysis, the proposed project is not reasonably likely to cause off-site adverse impacts to governmental services. Because the existing low floor elevations of the adjacent structures are only slightly above the seasonal high groundwater level, infiltration of stormwater in these stormwater facilities has the potential to be detrimental to the neighboring properties unless the proposed mitigation measure of sealing the bottom of the basins is implemented.
- Technical measures incorporated into the project plan to alleviate the practical difficulty (variance criterion 4) include the incorporation of underdrains below the biofiltration basins and the a clay liner to prevent runoff from infiltrating, thus minimizing the potential impacts to the adjacent structures. The 100-year flood elevation for both basins is contained on city property or within the right of way. The applicant dismissed relocating the stormwater facilities because of the need to provide rate control and water quality treatment for the project. The applicant also dismissed converting the biofiltration basins to self-contained, manufactured treatment devices due to the time for redesign and change order implications.
- With regard to variance criterion 5, the applicant has created the circumstances leading to the variances.

The engineer makes no determination as to whether there is an adequate technical basis for the managers to rely on to grant the requested variance. If the variance request is granted, the managers may wish to discuss a further condition with legal counsel:

- K1. The applicant must provide written indemnification of the RPBCWD, signed by a representative with authority to bind the city, from all claims and causes of action arising from the proposed noncompliance with the RPBCWD low-floor criteria.

Variance Request #2

The applicant requested a variance to allow the construction of the regional reuse system as part of the Market Boulevard reconstruction project planned to occur in 2025 because design of the roadway reconstruction project is not started. For purposes of the Board of Managers' consideration, the following factors were analyzed based on Rule K.

- Related to variance criteria #1 – The majority of the construction activities associated with permit 2024-013, if approved by the RPBCWD managers, will occur in 2024 – with some final site restoration activities and permit close-out in early to mid-2025. The city is planning to reconstruct Market Boulevard in 2025 and would install necessary infrastructure for the regional reuse system along Market Boulevard while the roadway is being reconstructed. The reuse system would likely be operation in late 2025 or early 2026. This results in roughly a 12-18 month delay between the completion of permit 2024-013 and the startup of the irrigation system.
- With regard to variance criteria 2 and 3 – Because the runoff from the site is conveyed in existing storm sewer to the existing stormwater treatment pond in the NW quadrant of Highway 5 and Market Boulevard and the applicant is providing rate control at the site boundary, the project is not likely cause adverse impacts to flood levels or downstream resources in the 12-18 month period before the reuse system is put online.
- Technical measures incorporated into the project plan to alleviate the practical difficulty (variance criterion 4) include relying on the treatment capacity of the existing stormwater pond in the NW quadrant of Highway 5 and Market Boulevard and downstream treatment train to provide water quality treatment before runoff enters Rice Marsh Lake. (These systems do not achieve compliance with applicable RPBCWD standards.)
- With regard to variance criterion 5, the applicant has created the circumstances leading to the variances by pursuing a regional reuse system to maximize the amount of runoff abstracted.

The RPBCWD engineer recommends granting the variance request based on the above analysis.

Applicable General Requirements:

1. The RPBCWD Administrator and Engineer shall be notified at least three days prior to commencement of work.
2. Construction must be consistent with the plans, specifications, and models that were submitted by the applicant that were the basis of permit approval. The date(s) of the approved plans, specifications, and modeling are listed on the permit. The grant of the permit does not in any way relieve the permittee, its engineer, or other professional consultants of responsibility for the permitted work.
3. The grant of the permit does not relieve the permittee of any responsibility to obtain approval of any other regulatory body with authority.

4. The issuance of this permit does not convey any rights to either real or personal property, or any exclusive privileges, nor does it authorize any injury to private property or any invasion of personal rights, nor any infringement of federal, state, or local laws or regulations.
5. In all cases where the doing by the permittee of anything authorized by this permit involves the taking, using or damaging of any property, rights or interests of any other person or persons, or of any publicly owned lands or improvements or interests, the permittee, before proceeding therewith, must acquire all necessary property rights and interest.
6. RPBCWD's determination to issue this permit was made in reliance on the information provided by the applicant. Any substantive change in the work affecting the nature and extent of applicability of RPBCWD regulatory requirements or substantive changes in the methods or means of compliance with RPBCWD regulatory requirements must be the subject of an application for a permit modification to the RPBCWD.
7. If the conditions herein are met and the permit is issued by RPBCWD, the applicant, by accepting the permit, grants access to the site of the work at all reasonable times during and after construction to authorized representatives of the RPBCWD for inspection of the work.

Findings

1. The proposed project includes the information necessary, plan sheets and erosion control plan for review.
2. The Applicant has requested a variance from compliance with the Rule J criteria related to the location of the proposed biofiltration basins WT-RG-1 and SF-RG-1 relative to the low floor elevation of existing structures.
3. The Applicant has requested a variance to allow the construction of the regional reuse system as part of the Market Boulevard reconstruction project planned to occur in 2025 rather than building the system as part of permit 2024-013.
4. If the variances from Rule J are approved, the proposed project will conform to Rules C and J if the Rule Specific Permit Conditions listed above are met.

Recommendation:

If the managers grant the variance (with such conditions as the managers may impose), the engineer recommends approval of the permit for a 2-year term, contingent upon:

1. The applicant providing the name and contact information of the general contractor responsible for the site.
2. The applicant must provide updated drawings to ensure the proposed stormwater facilities are constructed in a manner consistent with the submitted modeling, including but not limited to the proposed clay liner at biofiltration basins WT-RG-1 and SF-RG-1.
3. Demonstration of the necessary property rights to irrigate the greenspace on ISD 112 property.
4. Stormwater management facilities maintenance and operating requirements must be documented in an agreement with RPBCWD. A draft of the agreement and associated exhibits must be provided

for RPBCWD review and approval prior to execution. The agreement must also include a stormwater reuse monitoring and reporting plan that includes protection of the greenspace to be irrigated and metering of the volume of reuse, as well as maintenance specifics provided by the manufacturer(s) or installer(s) for the proprietary system.

By accepting the permit, when issued, the applicant agrees to the following stipulations:

1. Continued compliance with General Requirements.
2. Per Rule C, Subsection 3.3 the permit holder will be responsible for the inspection, maintenance and effectiveness of all erosion prevention and sediment control facilities, features and techniques. The permittee must inspect all erosion prevention and sediment control facilities and soil stabilization measures to ensure integrity and effectiveness until final site stabilization.
3. Per Rule J Subsection 5.6, upon completion of the site work, the permittee must submit as-built drawings demonstrating that at the time of final stabilization the stormwater management facilities conform to design specifications and functions as intended and approved by the District. As-built/record drawings must be signed by a professional engineer licensed in Minnesota and include, but not limited to:
 - a) the surveyed bottom elevations, water levels, and general topography of all facilities;
 - b) the size, type, and surveyed invert elevations of all stormwater facility inlets and outlets;
 - c) the surveyed elevations of all emergency overflows including stormwater facility, street, and other;
 - d) other important features to show that the project was constructed as approved by the Managers and protects the public health, welfare, and safety.
4. Providing the following additional close-out materials:
 - a) Documentation that constructed stormwater facilities perform as designed. This may include infiltration testing, flood testing, or other with prior approval from RPBCWD
 - b) Documentation that disturbed pervious areas remaining pervious have been decompacted per Rule C Subsection 3.2c criteria
5. Per Rule J, Subsection 3.1.b.ii measured infiltration capacity of the soils at the bottom of the biofiltration BMPs must be provided. The applicant must submit documentation verifying the infiltration capacity of the soils and that the volume control capacity is calculated using the measured infiltration rate. In addition, subsurface soil investigation is needed to verify adequate separation to groundwater (Rule J subsection 3.1.b.2). If infiltration capacity is less than needed to conform with the volume abstraction requirement in subsection 3.3b or there is inadequate separation to groundwater, design modifications to achieve compliance with RPBCWD requirements will need to be submitted (in the form of an application for a permit modification or new permit).
6. To close out the permit, the permit applicant must provide a chloride management plan that designates the individual authorized to implement the chloride management plan and the MPCA-certified salt applicator engaged in implementing the plan at the site.
7. Because the final layout and configuration of two proposed rain gardens used to comply with RPBCWD criteria in the Lotus Lake watershed are being coordinated with the adjacent land owners through the city's rain garden initiative program, the applicant will need to provide final details

during construction confirming the design is consistent with RPBCWD approvals (i.e, pollutant reductions and low floor separation).

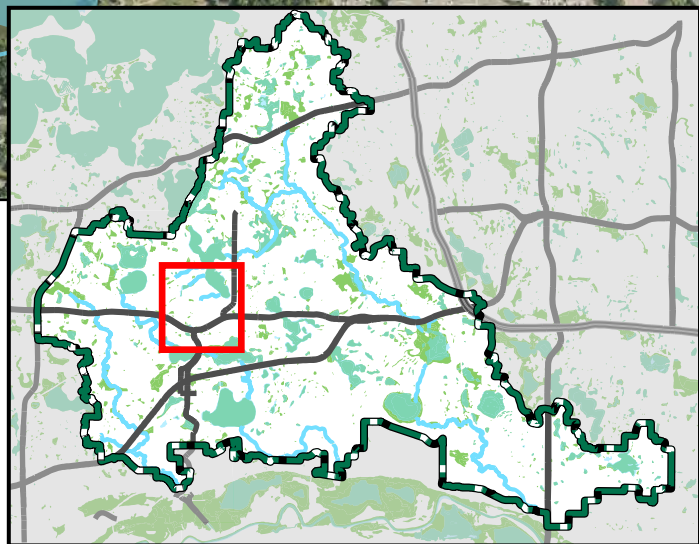
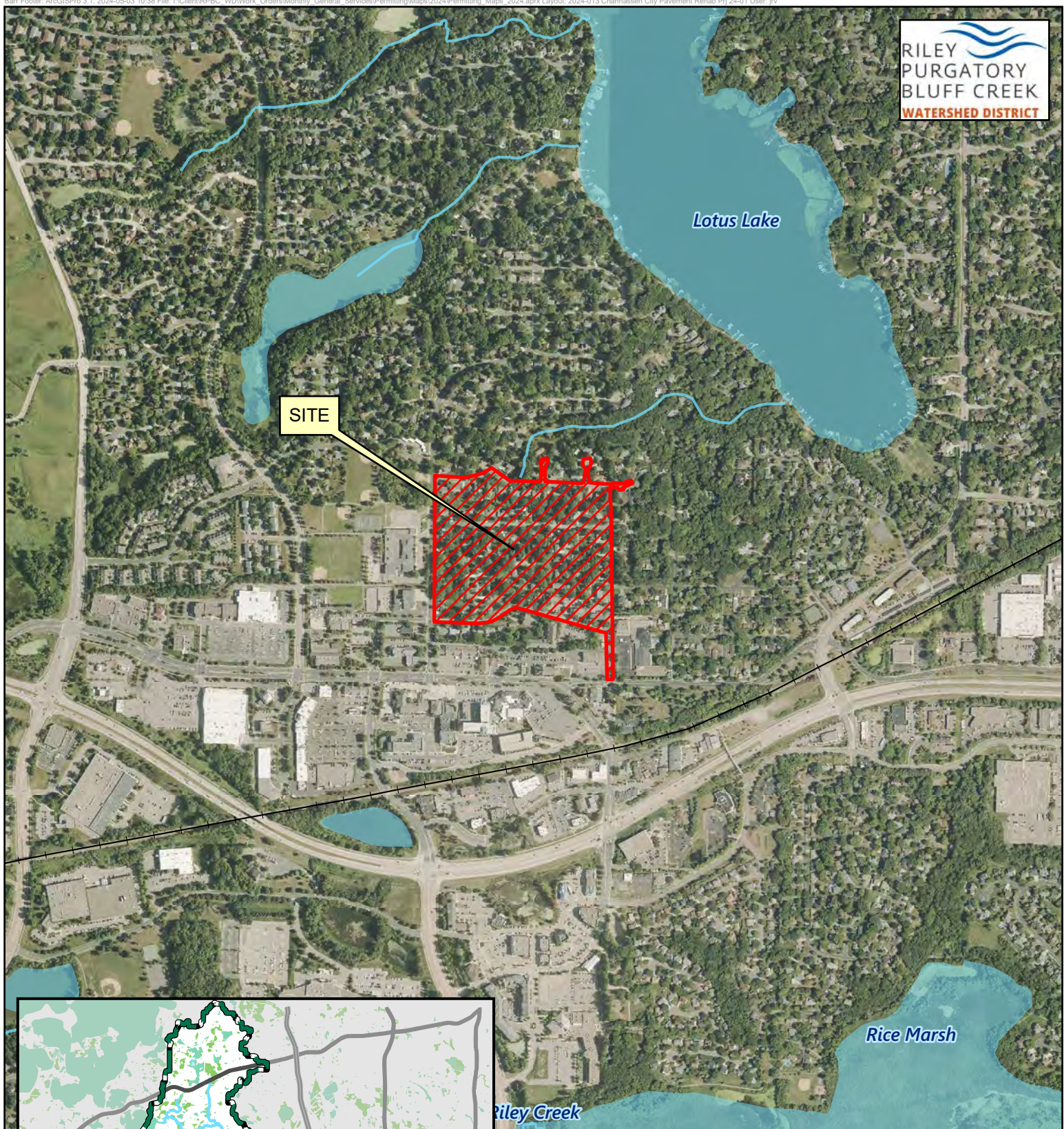

Feet



Permit Location Map

CHANHASSEN CITY PAVEMENT
REHAB PROJECT 24-01
Permit 2024-013
Riley Purgatory Bluff Creek
Watershed District



MEMORANDUM

To: Scott Sobiech, PE, Barr Engineering
From: Adam Tjaden, PE
Kimley-Horn and Associates, Inc.
Date: 4/11/2024
Subject: Chanhassen 24-01 – RPBCWD Rule Variance Request

Kimley-Horn and Associates, Inc. has prepared this memorandum to document the justification for requesting variances to RPBCWD rules. Variances are requested for two items within RPBCWD Rule J as described further in the following sections.

Rule J – Stormwater Management

3.1.a. Rate. *Limit peak runoff flow rates to that from existing conditions for the two-, 10- and 100-year frequency storm events using a nested 24-hour rainfall distribution, and a 100-year frequency, 10-day snowmelt event, for all points where stormwater discharge leaves the site.*

Variance Request: Allow the peak discharge rate for the snowmelt condition to increase for the proposed condition at the rate comparison location LL 6-2 GP.

As a result of siting water quality BMPs to satisfy project water quality requirements of Rule J; drainage patterns along Great Plains Boulevard and 76th Street were changed from existing condition to route additional area into the proposed BMPs GP-RG-1 and GP-RG-2. The shift in drainage patterns was necessitated by addition of curb and gutter, roadway sag point along 76th Street west of Great Plains Boulevard, and proposed BMP locations which were highly limited due to lack of right of way within the residential Chan View neighborhood. The proposed BMPs provide a significant amount of the required water quality for portion of the project in the Lotus Lake subwatershed. The discharge rate decreases an equal amount at the rate comparison point LL 1-25 SF, and both discharge points ultimately drain to Lotus Lake. Given the water quality provided by the proposed BMPs, and no change in rate to the ultimate resource Lotus Lake, this change in discharge rates will not substantially change the character or cause adverse effect to the resource, flood level, or be a substantial detriment to neighboring properties.

Variance Request: Allow the peak discharge rate for the 2-, 10-, and 100-year events to increase for the proposed condition at the rate comparison location RM 3-6 LAREDO.

As a result of a new sidewalk on the north side of Chan View there is a small amount (approximately 900 square feet) of additional impervious area to the drainage area RM 3-6 B from existing to proposed condition. The drainage area encompasses the north side of Chan View extending 150 feet east of Laredo Drive. The increase in rates is less than one tenth CFS for the 2-, 10-, and 100-year events. This drainage area ultimately routes to the existing detention pond RM_5 which provides additional rate control for the subwatershed but was not analyzed as part of this project as the total

Applicant made design revisions so the variance request from rate control is no longer needed

contributing area to RM_5 encompasses a significantly larger drainage network than the project. Given the additional rate control provided by RM_5, the change in discharge rates will not substantially change the character or cause adverse effect to the resource, flood level, or be a substantial detriment to neighboring properties.

3.6b Low-floor Elevation. *A stormwater-management facility must be:*

- i. constructed at an elevation that ensures that no adjacent habitable building will be brought into noncompliance with a standard in this subsection 3.6.*
- ii. Alternatively, a stormwater-management facility may be constructed at a location and elevation set according to Appendix J1 – “Low Floor Elevation Assessment,” which is incorporated into and made a part of these rules. If Appendix J1 is used, the lowest opening where surface water can enter the structure must be a minimum of two feet above the 100-year high water elevation or one foot above the emergency overflow.*

Variance Request: Allow the horizontal separation distance and estimated depth to water table of BMP WT-RG-1 to 502 76th Street, and BMP SF-RG-1 to 7554 Great Plains Boulevard.

According to Appendix J.1, plot 2, BMPs WT-RG-1 and SF-RG-1 do not meet the minimum permissible depth to water table based on the horizontal separation distance from the BMP to the adjacent structure. However, the BMPs are designed for filtration with a drain tile outlet raised 3 inches above native soils to provide some amount of volume reduction and additional water quality benefit. The tile outlet significantly reduces the infiltration volume influencing groundwater mounding. No groundwater was observed during the soil boring investigations, the estimated groundwater elevation used in this analysis was noted only by iron oxide seams. Given the conservative assumption of water table elevation and minimal infiltrated volume, a variance for the minimal permissible depth to water table is requested as it will not substantially change the character or cause adverse effect to the resource, flood level, or be a substantial detriment to neighboring properties.

The following discussion documents the steps taken in reviewing the low floor criteria for each BMP:

Rule J Appendix 1 was followed assuming existing structure basements are adjacent to the proposed rain garden BMPs in this residential area. The following sources of information were used:

- 1) Soil borings within or adjacent to BMPs were reviewed for observed ground water or potential seasonal high ground water.
- 2) Low floors were estimated to be 8 feet below existing grade at each structure. Existing grade was estimated from LiDAR contours (MnTOPO).
- 3) Horizontal distance from the BMP flooded perimeter to the structures were measured from proposed grading and topo files (survey and GIS).

Table 2 (clay) in Appendix J1 was used to determine the minimum permissible depth to water table (below the low floor elevation). An exception from Rule J.3.6b is requested based on the minimal duration of ponding, and minimal depth of infiltration for the following locations:

- 1) WT-RG-1: Soil boring P-3 notes sandy lean clay with iron oxide seams from approximately 7-11 feet below grade. This indicates the potential for seasonally high ground water elevation is roughly 984'. The estimated low floor elevation of the adjacent structure to BMP WT-RG-1 (502 76th Street) is 8 feet below the existing grade; 984.2'. Appendix J1 indicates the minimum permissible depth to water table is just over 6 feet. A variance from Rule J.3.6b is requested based on the minimal duration of ponding, and minimal depth of infiltration.
- 2) SF-RG-1: Soil boring P-5 notes sandy lean clay with iron oxide seams approximately 4.5-11 feet below grade. This indicates the potential for seasonally high ground water elevation is roughly

975'. The estimated low floor elevation of the adjacent structure to BMP SF-RG-4 (7554 Great Plains Boulevard) is 8 feet below existing grade; 975.6'. Appendix J1 indicates the minimum permissible depth to water table is just under 2 feet. A variance from Rule J.3.6b is requested based on the minimal duration of ponding, and minimal depth of infiltration.

- 3) Note, for each BMP the lowest adjacent grade of existing ground is at least one foot above the emergency overflow of a stormwater-management facility.

A summary table of the depth to water table is provided below. The following notes support the request for variance for the locations that do not meet the minimum permissible depth.

- 1) Appendix J1 assumes the duration of flooding or high-water level in the pond of 25 days. However, the proposed BMPs are expected to draw down within 24 hours (assuming 0.8 inch/hour for filtration media) based on a maximum ponding depth of 18 to 24 inches, drain tile, and filtration media with a high rate of filtration.
- 2) The drain tile is raised 3 inches to provide some volume abstraction, and additional pollutant removals. Based on assumed infiltration rate of 0.06 in/hour the volume below the tile will be infiltrated in less than 48 hours based on 40% voids in the filtration media under the tile.

BMP	EXISTING STRUCTURE GRADE (FT)	ESTIMATED LOW FLOOR EL. (FT)	SEASONAL HIGH GROUND WATER EL. (FT)	DEPTH TO WT	CALCULATED DEPTH TO G.W. FROM LOW FLOOR (FT)	MINIMUM DEPTH TO G.W. (FT) (PLOT 2)	HORIZONTAL SEPARATION TO STRUCTURE (FT)	STRUCTURE ADDRESS	BORING REFERENCE	BORING NOTE	EXCEPTION
WT-RG-1	992.2	984.2	984	8.2	0.2	6	15	502 76TH ST.	P-3	NO WATER OBSERVED, IRON OXIDE 7' BELOW GRADE (984').	YES
GP-RG-1	994	986	977	17	9	2	70	400 76TH ST.	B-4	NO WATER OBSERVED, NO REDOX.	NO
	994.2	986.2	977	17.2	9.2	1	100	7601 GREAT PLAINS BLVD.	B-4	NO WATER OBSERVED, NO REDOX.	NO
GP-RG-2	990	982	977	13	5	2	65	401 SANTA FE TR.	B-4	NO WATER OBSERVED, NO REDOX.	NO
	991	983	977	14	6	0.5	135	7561 GREAT PLAINS BLVD.	B-4	NO WATER OBSERVED, NO REDOX.	NO
SF-RG-1	983.6	975.6	975	8.6	0.6	1.6	80	7554 GREAT PLAINS BLVD.	P-5	NO WATER OBSERVED, IRON OXIDE 4.5' BELOW GRADE (975')	YES
	987.5	979.5	975	12.5	4.5	0.5	135	400 SANTA FE TR.	P-5	NO WATER OBSERVED, IRON OXIDE 4.5' BELOW GRADE (975')	NO

CITY OF CHANHASSEN, MINNESOTA

CARVER COUNTY

2024 CITY PAVEMENT REHABILITATION PROJECT

VARIOUS LOCATIONS CITY PROJECT NO. 24-01

CONSTRUCTION PLANS FOR MILL AND OVERLAY, FULL DEPTH RECLAMATION, BITUMINOUS SURFACING, CONCRETE CURB AND GUTTER, ADA IMPROVEMENTS, STORM SEWER IMPROVEMENTS, UTILITY IMPROVEMENTS.

LOCATED ON: CHAN VIEW AREA, DEL RIO DR AREA, SANTA FE TRAIL AREA, STONE CREEK AREA

GOVERNING SPECIFICATIONS

THE 2020 EDITION OF THE MINNESOTA DEPARTMENT OF TRANSPORTATION "STANDARD SPECIFICATIONS FOR CONSTRUCTION" AND THE "SUPPLEMENTAL SPECIFICATIONS" DATED SEPTEMBER 2022 SHALL GOVERN. ALL TRAFFIC CONTROL DEVICES SHALL CONFORM TO THE LATEST MINNESOTA MANUAL ON UNIFORM TRAFFIC CONTROL DEVICES, INCLUDING THE LATEST "FIELD MANUAL FOR TEMPORARY TRAFFIC CONTROL ZONE LAYOUTS."

THE LATEST EDITIONS OF THE MNDOT AND CITY ENGINEERS ASSOCIATION OF MINNESOTA STANDARD SPECIFICATIONS ARE AMENDED BY THE CITY OF CHANHASSEN SPECIFICATIONS FOR CONSTRUCTION DATED MARCH 2023.

INDEX

SHEET NO.	DESCRIPTION
1	TITLE SHEET
2-5	STATEMENT OF ESTIMATED QUANTITIES
6-7	GENERAL NOTES
8-10	EARTHWORK NOTES AND TABULATIONS
11-16	STANDARD PLANS
17-28	STANDARD PLATES
29-30	TYPICAL SECTIONS
31-32	GENERAL LAYOUTS & BID ALT SPLITS
33-43	ALIGNMENT PLAN & TABULATIONS
44-46	STORM WATER POLLUTION PREVENTION PLAN
47-66	REMOVAL AND EROSION CONTROL PLANS
67	UTILITY DETAILS
68-87	UTILITY PLAN & PROFILE
88-107	DRAINAGE PLAN & PROFILE
108-110	DRAINAGE LATERALS
111-114	RAIN GARDEN DETAILS
115-116	DRAINAGE TABULATIONS
117-136	CONSTRUCTION PLAN & PROFILE
137-148	INTERSECTION DETAILS
149-160	SIGNING AND STRIPING PLANS
161-188	CROSS SECTIONS

LEGEND

	EXISTING GATE VALVE
	EXISTING HYDRANT
	EXISTING CURB BOX
	EXISTING WATERMAIN MANHOLE
	EXISTING SANITARY MANHOLE
	EXISTING STORM MANHOLE
	EXISTING GAS MANHOLE
	EXISTING CATCH BASIN
	EXISTING POWER POLE
	SOIL BORING
	EXISTING CABLE TV BOX
	EXISTING TELEPHONE BOX
	EXISTING ELECTRICAL MANHOLE
	EXISTING ELECTRICAL TRANSFORMER
	EXISTING LIGHT POLE
	EXISTING MAILBOX
	EXISTING SANITARY SEWER
	EXISTING STORM SEWER
	EXISTING WATERMAIN
	EXISTING CURB AND GUTTER
	EXISTING FIBER OPTIC
	EXISTING GAS MAIN
	EXISTING OVERHEAD POWER/COMMUNICATION
	EXISTING UNDERGROUND POWER
	EXISTING FENCE
	EXISTING RETAINING WALL
	EXISTING TREE
	EXISTING TREE LINE
	EXISTING STREET SIGN
	PROPOSED GATE VALVE
	PROPOSED HYDRANT
	PROPOSED MANHOLE (STORM OR SANITARY)
	PROPOSED CATCH BASIN
	PROPOSED WATERMAIN
	PROPOSED STORM SEWER
	PROPOSED SANITARY SEWER
	PROPOSED CIPP SANITARY SEWER LINING
	PROPOSED CURB AND GUTTER
	PROPOSED RETAINING WALL
	DRAIN TILE
	EXISTING RIGHT-OF-WAY
	CONSTRUCTION LIMITS

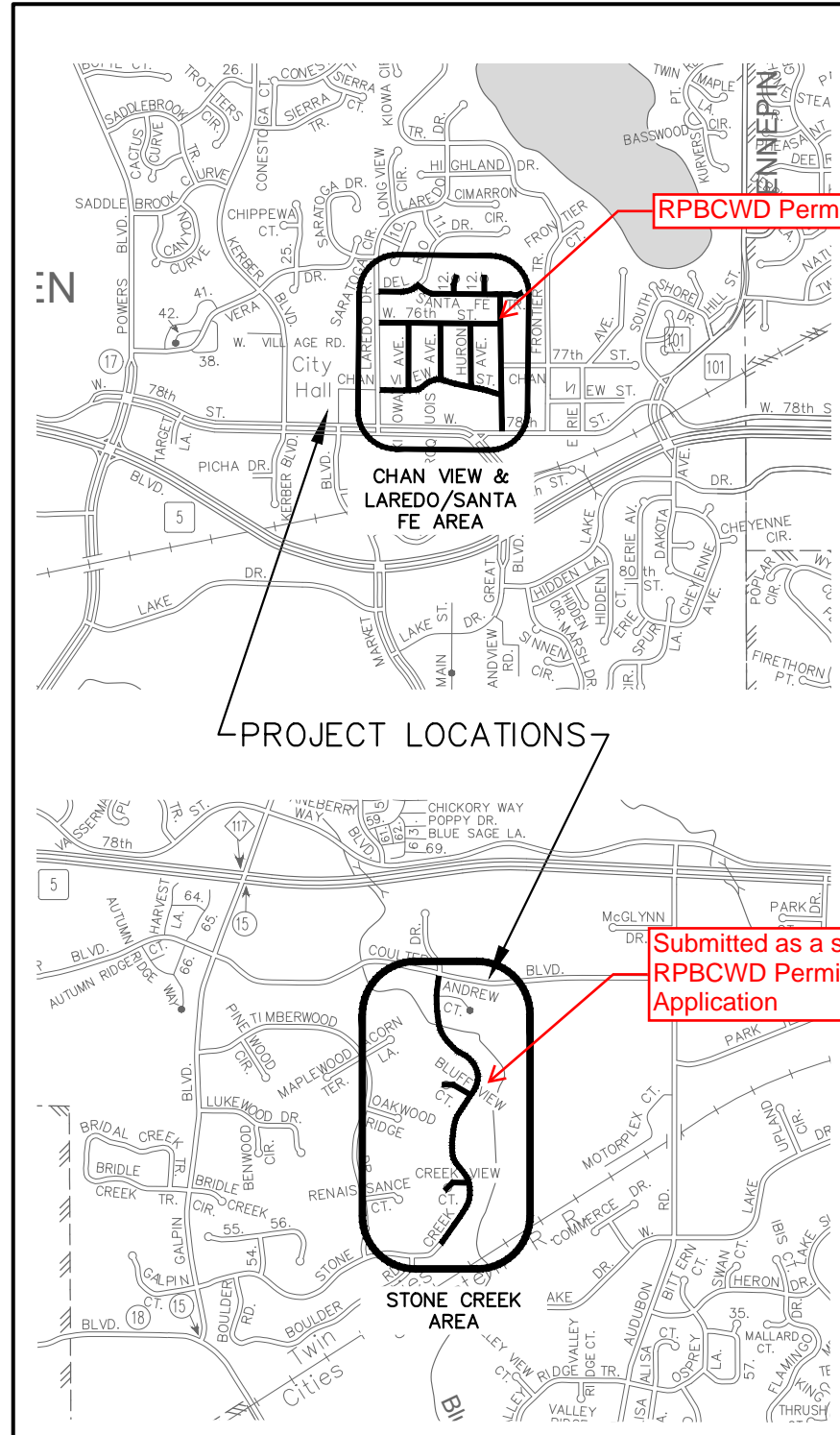

RPBCWD Permit 2024-013

PROJECT LOCATIONS

Submitted as a separate RPBCWD Permit Application



PLAN SET SCALES

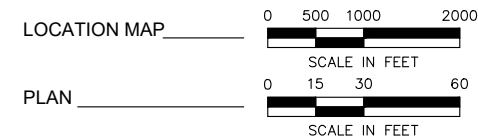

PROJECT LOCATION
CARVER COUNTY

NOTE:
THE SUBSURFACE UTILITY INFORMATION IN THIS PLAN IS UTILITY QUALITY LEVEL D. THIS QUALITY LEVEL WAS DETERMINED ACCORDING TO THE GUIDELINES OF CI/ASCE 38-02, ENTITLED "STANDARD GUIDELINES FOR THE COLLECTION AND DEPICTION OF EXISTING SUBSURFACE UTILITY DATA".

THE EXACT LOCATION OF UNDERGROUND UTILITIES SHOWN IN THIS PLAN SET ARE UNKNOWN. THE CONTRACTOR SHALL CONTACT GOPHER STATE ONE PRIOR TO STARTING ANY EXCAVATION.

GOPHER STATE ONE CALL SYSTEM.....1-800-252-1166

PLAN REVISIONS		
DATE	SHEET NO.	APPROVED BY

THIS PLAN SET CONTAINS 188 SHEETS

Kimley»Horn

I HEREBY CERTIFY THAT THIS PLAN, SPECIFICATION OR REPORT WAS PREPARED BY ME OR UNDER MY DIRECT SUPERVISION AND THAT I AM A DULY LICENSED PROFESSIONAL ENGINEER UNDER THE LAWS OF THE STATE OF MINNESOTA.

DATE 02/29/2024 REG. NO. 59057

ENGINEER *Michael A. Kirsch*
MICHAEL A. KIRSCH

APPROVED *Charles J. Howley*
CITY OF CHANHASSEN ENGINEER 2024

GENERAL TRAFFIC CONTROL NOTES

- ADVANCED NOTIFICATION SIGNAGE WITH A SCHEDULED START DATE IS REQUIRED TO BE PLACED 7 CALENDAR DAYS PRIOR TO THE START OF PAVEMENT REMOVAL OR ANY SUBSTANTIAL WORK. ONCE THE SIGNAGE IS IN PLACE, THE SCHEDULE MUST BE MAINTAINED. INTERIM DETOURS ON ROADWAYS OUTSIDE OF PROJECT LIMITS WILL ALSO REQUIRE 7-DAY ADVANCE NOTICE SIGNS.
- MAINTAIN ACCESS TO RESIDENCES AND BUSINESSES AT ALL TIMES THROUGHOUT CONSTRUCTION. DRIVEWAYS SHALL BE RAMPED SO THAT DROP-OFFS ARE NO MORE THAN TWO INCHES IN HEIGHT. MAINTAIN ACCESS TO AND FROM THE SITE FOR CONCURRENT CONSTRUCTION PROJECTS, PRIVATE UTILITY IMPROVEMENTS/RELOCATIONS, AND AS OTHERWISE PROVIDED FOR IN THE SPECIFICATIONS.
- REOPEN ALL STREETS TO TWO-WAY TRAFFIC AT THE END OF EACH WORK DAY WITH A MINIMUM OF TWO 11-FOOT LANES AND GRAVEL SURFACING.
- CITY STREETS THAT ARE INCLUDED IN THE 2024 4TH OF JULY PARADE AND STAGING ROUTES SHALL NOT HAVE ANY REMOVALS OR CONSTRUCTION COMMENCE UNTIL AFTER THE 4TH OF JULY WEEKEND. THESE STREETS INCLUDE; CHAN VIEW, LAREDO DRIVE, WEST 78TH STREET, IROQUOIS STREET, HURON AVENUE.
- CONSTRUCT COMMERCIAL DRIVEWAY APRONS AND VALLEY GUTTERS IN HALVES TO MAINTAIN ACCESS AND USE HIGH EARLY STRENGTH CONCRETE. TEMPORARY DRIVEWAY ACCESSES MAY BE REQUIRED. COORDINATE THE LOCATIONS OF TEMPORARY ACCESSES WITH THE ENGINEER AND PROPERTY OWNER. ALL COSTS ASSOCIATED WITH SUPPLYING ACCESS ARE CONSIDERED INCIDENTAL.
- MAINTAIN GARBAGE AND RECYCLING SERVICE AT ALL TIMES. PROVIDE ACCESS FOR GARBAGE AND DELIVERY VEHICLES. WHEN INFEASIBLE TO MAINTAIN SUCH ACCESS, COLLECT CONTAINERS, RELOCATE THEM TO A LOCATION WHERE SUITABLE ACCESS CAN BE PROVIDED, AND RETURN CONTAINERS IN GOOD WORKING CONDITION TO THE SAME PROPERTY FROM WHICH THEY WERE TAKEN. COSTS FOR PROVIDING ACCESS OR HAULING CONTAINERS TO AN ACCESSIBLE LOCATION ARE INCIDENTAL.
- INSTALL ALL TRAFFIC CONTROL DEVICES IN ACCORDANCE WITH THE LATEST EDITION OF THE MINNESOTA MANUAL ON UNIFORM TRAFFIC CONTROL DEVICES (MN MUTCD) INCLUDING THE LATEST FIELD MANUAL FOR TEMPORARY TRAFFIC CONTROL ZONE LAYOUTS. TRAFFIC CONTROL NOT IN COMPLIANCE WITH MN MUTCD WILL BE SUBJECT TO VIOLATION IN ACCORDANCE WITH THE SPECIAL PROVISIONS.
- THE ITEM "TRAFFIC CONTROL" BID AS "LUMP SUM" INCLUDES ALL COSTS FOR PROVIDING TEMPORARY CONTROLS SPECIFIED IN THE PLAN AND OTHER TRAFFIC CONTROL REQUIRED PER THE MN/MUTCD DUE TO THE CONTRACTORS OPERATIONS FOR COMPLETION OF THE PROJECT INCLUDING BUT NOT LIMITED TO, WORKING UNDER TRAFFIC, TEMPORARY ROAD CLOSURES IN FULL OR TO THRU TRAFFIC, TEMPORARY LANE CLOSURES, ADJUSTMENTS TO THE TRAFFIC CONTROL PLAN FOR LARGE AND SMALL SCALE STAGING OPERATIONS, AND NECESSARY DETOURS FOR MOTORISTS, BICYCLISTS, AND/OR PEDESTRIANS. THE AMOUNT BID SHALL ALSO INCLUDE SUFFICIENT TRAFFIC CONTROL FOR WARNING OF POTENTIAL HAZARDS DURING CONSTRUCTION INCLUDING BUT NOT LIMITED TO FLASHING BARRICADES AROUND EQUIPMENT AND OBSTRUCTIONS.
- PREVENT TRACKING OF BITUMINOUS MATERIAL ONTO THE ADJACENT STREETS. IF MATERIAL IS TRACKED ONTO ADJACENT STREETS, RESTORE THE PAVEMENT AND STRIPING TO THE SATISFACTION OF THE AGENCY HAVING JURISDICTION OVER THE ROADWAY AND CITY.
- SUBMIT A TRAFFIC CONTROL PLAN, INCLUDING ANY PROPOSED DETOUR ROUTES, TO THE ENGINEER FOR APPROVAL PRIOR TO CONSTRUCTION. MAINTAIN ACCESS TO RESIDENCES AND BUSINESSES AT ALL TIMES. USE OF FLAGGERS MAY BE REQUIRED AND IS INCIDENTAL.
- DELINEATE TRAFFIC LANES TO BE USED DURING CONSTRUCTION TO KEEP VEHICLES A SAFE DISTANCE AWAY FROM ANY EXCAVATION. PROJECT A 1:2 OR FLATTER SLOPE FROM THE BOTTOM OF THE EXCAVATION TO THE EDGE OF THE TRAFFIC LANE.
- CONFINE ANY EQUIPMENT OR MATERIALS LEFT IN THE ROADWAY OVERNIGHT TO THE PROJECT LIMITS. DO NOT RESTRICT THE REQUIRED 11-FOOT LANES. PROTECT THE EQUIPMENT AND MATERIALS WITH TYPE 1 BARRICADES ON ALL SIDES VISIBLE TO TRAFFIC.
- MAINTAIN ACCESS FOR EMERGENCY VEHICLES AT ALL TIMES.

CONSTRUCTION NOTES:

- THE UTILITY INFORMATION IN THIS PLAN IS UTILITY QUALITY LEVEL D. THIS UTILITY LEVEL WAS DETERMINED ACCORDING TO THE GUIDELINES OF CI/ASCE 38-22, ENTITLED STANDARD GUIDELINE FOR INVESTIGATING AND DOCUMENTING EXISTING UTILITIES.
- SAW CUT EXISTING PAVEMENT THAT IS ADJACENT TO ANY NEW PAVEMENT. COAT THE SAWED EDGE WITH TACK COAT PRIOR TO PAVING. (INCIDENTAL)
- ALL USES OF THE WORD "INCIDENTAL" IN THESE CONSTRUCTION DOCUMENTS SHALL BE CONSTRUED TO MEAN INCIDENTAL WORK FOR WHICH NO DIRECT COMPENSATION SHALL BE MADE.
- TAKE REASONABLE CARE TO AVOID DAMAGE TO PRIVATE IRRIGATION SYSTEMS. IF PRIVATE IRRIGATION SYSTEMS ARE DAMAGED DUE TO CONSTRUCTION OPERATIONS, NOTIFY THE CITY IMMEDIATELY. EXPOSE DAMAGED SPRINKLE HEADS AND LEAVE ON THE LAWN OUTSIDE OF THE WORK AREA. PINCH SHUT DAMAGED IRRIGATION PIPES AND LEAVE ABOVE GROUND.
- PROVIDE NO GREATER THAN A TWO INCH DROP OFF AT ACCESS POINTS ALONG THE CURB LINE. WITH PROTECTION, DROP-OFFS GREATER THAN TWO INCHES WILL BE ALLOWED DURING ACTIVE CONSTRUCTION BUT NOT BEFORE OR AFTER.
- ALL MATERIAL NOT UTILIZED ON THIS PROJECT SHALL BECOME THE PROPERTY OF THE CONTRACTOR AND DISPOSED OF OFF THE R.O.W. IN ACCORDANCE WITH SPECIFICATION 2104.
- RE-ESTABLISH ALL TURF THAT HAS BEEN DISTURBED DUE TO CONSTRUCTION ACTIVITIES. MINIMIZE THE IMPACTED AREA AND PROTECT EXISTING TURF TO THE GREATEST EXTENT POSSIBLE.
- STRIP TURF AND SALVAGE TOPSOIL FROM AREAS TO BE DISTURBED BY CONSTRUCTION. SALVAGING AND REUSING TOPSOIL SHALL BE INCIDENTAL TO SODDING TYPE LAWN.
- FOR MILL & OVERLAY AREAS, AFTER MILLING THE PAVEMENT TO THE REQUIRED DEPTH AND PRIOR TO OVERLAYING, AIR BLAST ANY DETERIORATED CRACKS AND JOINTS TO REMOVE LOOSE OR DETERIORATED BITUMINOUS SURFACING. AIR BLAST WITH HIGH-PRESSURE (100+ PSI) EQUIPMENT AND IS INCIDENTAL UNDER SPECIFICATION 2232.
- FOR MILL & OVERLAY AREAS, PATCH CRACKS OR DEPRESSIONS RESULTING AFTER SURFACE REPAIR, AIR BLASTING, SWEEPING, OR MILLING OPERATIONS WHICH ARE GREATER THAN 1" WITH BITUMINOUS PATCHING MIXTURE. PATCH THESE AREAS AHEAD OF THE PAVING OPERATION AND COMPACT WITH A SMALL VIBRATORY OR PNEUMATIC ROLLER. FILL DEPRESSIONS OF LESS THAN 1" WITH THE BITUMINOUS WEAR COURSE MIXTURE IN FRONT OF THE PAVER AS DIRECTED BY THE ENGINEER.
- CONTRACTOR IS RESPONSIBLE FOR DUST CONTROL ON THE PROJECT SITE. COORDINATE WITH THE CITY FOR ACCESS TO WATER IF NECESSARY FOR CONTROLLING DUST.
- AFTER THE NON-WEAR COURSE HAS BEEN PAVED AND CASTINGS AND IRON RAISED, CLEAN ALL SANITARY SEWER WITHIN THE PROJECT LIMITS. WORK WILL BE PAID UNDER "CLEAN PIPE SEWER." CLEAN OUT ALL GATE VALVE BOXES (INCIDENTAL).
- COORDINATE WITH POSTAL PATRONS AND THE LOCAL POSTAL AUTHORITY TO RELOCATE MAILBOXES AS NECESSARY DURING CONSTRUCTION AND TO REINSTALL MAILBOXES AFTER CONSTRUCTION. IN NO CASE SHALL A POSTAL PATRON BE WITHOUT A POST CARRIER ACCESSIBLE MAILBOX AS DESIGNATED BY THE POSTMASTER.
- SUBMIT TO THE ENGINEER FOR APPROVAL THE LOCATION OF STAGING AREAS, STOCKPILE AREAS, MATERIAL AND EQUIPMENT STORAGE AREAS FOR EACH PROJECT. PROPER SAFETY SIGNING, DELINEATION, SECURITY, EROSION CONTROL, AND RESTORATION IS INCIDENTAL.
- PAVE MILLED SURFACES WITHIN 72-HOURS.
- PAVE RECLAIMED SURFACES WITHIN 14-DAYS OF THE COMPLETION OF CURB AND GUTTER WORK.
- CONTRACTOR SHALL PROTECT EXISTING FOLIAGE, CLEARING AND GRUBBING OF EXISTING FOLIAGE SHALL BE AS DIRECTED BY THE ENGINEER, AS NECESSARY, CONTRACTOR SHALL SELECTIVELY TRIM BRANCHES AND LIMBS PRIOR TO RIPPING AND FURTHER DAMAGING TREES AND SHRUBS, COORDINATE WITH ENGINEER (INCIDENTAL).
- CONTRACTOR SHALL REPLACE COMPLETE UTILITY IMPROVEMENTS PRIOR TO PAVING THE FINAL WEARING COURSE.



REMOVAL NOTES:

- REMOVE AND REPLACE CONCRETE CURB AND GUTTER AS DETERMINED BY ENGINEER IN FIELD (SPOT REPLACEMENT).
- PRIOR TO REMOVALS, INSTALL EROSION CONTROL DEVICES.
- REMOVALS SHALL BE LIMITED TO AREAS WITHIN THE DEFINED PROJECT LIMITS. IF CONTRACTORS OPERATIONS CAUSE DAMAGE OR REQUIRE RESTORATION OUTSIDE OF DEFINED PROJECT LIMITS, REPAIR OR RESTORE AT NO ADDITIONAL COST TO THE CITY.
- FOLLOW ALL LOCAL, STATE, AND FEDERAL REGULATIONS IN DISPOSING OF MATERIALS REMOVED FROM THIS SITE.
- PAVEMENT REMOVAL LIMITS SHOWN ON THE PLAN ARE APPROXIMATE. REMOVAL LIMITS WILL BE DETERMINED IN THE FIELD BY THE ENGINEER. VERIFY REMOVAL LIMITS WITH ENGINEER PRIOR TO SAWCUTTING.
- REMOVE ALL TREES, SHRUBS, AND VEGETATION DESIGNATED FOR REMOVAL BY THE ENGINEER.
- PROTECT ALL ITEMS DESIGNATED FOR SALVAGE AND PROVIDE APPROPRIATE STORAGE UNTIL RE-INSTALLATION. ANY ITEMS DESIGNATED TO BE SALVAGED WHICH ARE DAMAGED SHALL BE REPLACED WITH NEW AT NO ADDITIONAL COST TO THE OWNER. REPAIR OF DAMAGED ITEMS SHALL NOT BE ALLOWED UNLESS APPROVED BY THE ENGINEER.
- ANY LANDSCAPING MATERIALS WITHIN R.O.W. TO BE REMOVED SHALL BE DESIGNATED IN ADVANCE BY THE ENGINEER AND SHALL BE CONSIDERED INCIDENTAL.
- DURING CONSTRUCTION, PROTECT ALL ITEMS NOT IDENTIFIED FOR REMOVAL (INCIDENTAL).
- REMOVAL & DISPOSAL OF EXCESS RECLAIM SHALL BE PAID FOR AS PART OF THE PLAN QUANTITY (P) FOR THE "COMMON EXCAVATION" BID ITEM.
- ALL SALVAGED SIGNS SHALL BE RETURNED TO PUBLIC WORKS UNLESS OTHERWISE STATED.
- ENGINEER TO IDENTIFY AND MARK CONCRETE AND BITUMINOUS DRIVEWAY REMOVAL LOCATIONS.
- ENGINEER TO IDENTIFY AND MARK CONCRETE AND BITUMINOUS WALK REMOVAL LOCATIONS.

UTILITY CONSTRUCTION NOTES

- WATER AND SANITARY SERVICE LOCATIONS SHOWN ARE APPROXIMATE AND ALL SERVICES MAY NOT BE SHOWN.
- ALL CONNECTIONS TO EXISTING UTILITIES (WM, SAN, STM, ETC.) SHALL BE FIELD VERIFIED FOR LOCATION AND ELEVATION PRIOR TO SCHEDULING THE WORK (INCIDENTAL)
- TRENCH BOXES OR OTHER TRENCH STABILIZATION METHODS MAY BE REQUIRED DURING CONSTRUCTION TO STAY WITHIN CONSTRUCTION LIMITS AND MINIMIZE REMOVAL LIMITS (INCIDENTAL).
- UNDERGROUND UTILITIES EXIST WITHIN THE PROJECT AREA. HAVE ALL UNDERGROUND UTILITIES LOCATED PRIOR TO THE START OF CONSTRUCTION AND COORDINATE THE WORK SCHEDULE WITH UTILITY COMPANY CREWS PERFORMING RELOCATION WORK. CONTACT EACH RESPECTIVE UTILITY COMPANY AND SCHEDULE WORK AROUND WORK PERFORMED BY PRIVATE UTILITY COMPANIES. SHOW PRIVATE UTILITY WORK ON THE PROJECT SCHEDULE AND UPDATE FOR EACH WEEKLY CONSTRUCTION MEETING.
- REFER TO PROJECT SPECIFICATIONS FOR STRUCTURE CASTING FRAME & COVER REQUIREMENTS.
- COMPLETE UTILITY CONSTRUCTION PRIOR TO RECLAMATION OR PAVEMENT REMOVAL

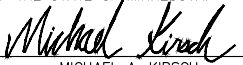
K:\TOW_Civil\Civil\CHANHASSEN\2024 CITY STREET REHAB-RECONSTRUCT\CAD\Plan Sheets\2024_PaveRehab-NOTE.dwg February 29, 2024 - 6:51pm

No.	Date	Revisions	App.	DRAWING NAME 2024_PaveRehab-NOTE.dwg	 <p>11995 SINGLETREE LANE, SUITE 225, EDEN PRAIRIE, MN 55344 PHONE: 612-315-1272 WWW.KIMLEY-HORN.COM</p>	<p>I HEREBY CERTIFY THAT THIS PLAN, SPECIFICATION OR REPORT WAS PREPARED BY ME OR UNDER MY DIRECT SUPERVISION AND THAT I AM A DULY LICENSED PROFESSIONAL ENGINEER UNDER THE LAWS OF THE STATE OF MINNESOTA.</p>  <p>MICHAEL A. KIRSCH DATE: 02/29/2024 MN LIC. NO. 59057</p>	 <p>CITY OF CHANHASSEN 2024 CITY PAVEMENT REHABILITATION PROJECT</p> <p>GENERAL NOTES</p>	CITY PROJECT	24-01	SHEET NO. 6
188										

K:\TOW_Civil\CITY OF CHANHASSEN\2024 CITY STREET REHAB-RECONSTRUCT\CAD\Plan Sheets\2024_PaveRehab-NOTE.dwg February 29, 2024 - 6:51pm

UTILITY CONTACTS			
AGENCY	NAME	PHONE NUMBER	EMAIL
ARVIG	RICKY ASP	218-346-5500	RICKY.ASP@ARVIG.COM
CENTER POINT ENERGY	JUSTIN KLINGL	612-321-5207	JUSTIN.KLINGL@CENTERPOINTENERGY.COM
CITY OF CHANHASSEN	GEORGE BENDER	952-227-1164	GBENDER@CI.CHANHASSEN.MN.US
JAGUAR COMMUNICATIONS	MICHAEL BROADWATER	507-219-8081	MBROADWATER@JAGCOM.NET
LUMEN (CENTURYLINK)	CHUCK DAHER	612-298-2825	CDAHER@CONGRUEX.COM
MCI/VERIZON	GREG ALLEN	800-624-9675	GREG.ALLEN@VERIZON.COM, MCIMSPFIBER@VERIZON.COM
MEDIACOM	CHRISTOPHER THOMPSON	952-923-1073	CTHOMPSON@MEDIACOMCC.COM
METRONET FIBER	DANIEL HOLMQUIST	507-219-8081	DANIEL.HOLMQUIST@METRONET.COM
MINNESOTA VALLEY ELECTRIC	CURT CORDT	952-492-8210	CCORDT@MVEC.NET
XCEL ENERGY	TAYLOR SPERL JEFF V SCHEI	952-470-3339 612-494-0611	TAYLOR.A.SPERL@XCELENERGY.COM JEFF.V.SCHEI@XCELENERGY.COM
ZAYO BANDWIDTH	JASON OVERKAMP	952-230-9660	JOVERKAMP@CONGRUEX.COM

BASIS OF QUANTITIES		
ITEM NO.	DESCRIPTION	BASIS
2211	AGGREGATE BASE CLASS 5	140 LBS/CU FT*
2360	TYPE SP 9.5 WEARING COURSE MIX (2,C)	113 LBS/SQ YD-INCH
2360	TYPE SP 12.5 WEARING COURSE MIX (3,C)	113 LBS/SQ YD-INCH
2360	TYPE SP 19.0 NON-WEARING COURSE MIX (3,C)	113 LBS/SQ YD-INCH
2575	MNDOT SEED MIX 25-151	180 LBS/ACRE
2575	FERTILIZER - MNDOT TYPE 3	300 LBS/ACRE

* BASIS OF QUANTITY IS FOR THE COMPACTED VOLUME CONDITION (CV)

MnDOT STANDARD PLATES	
THE FOLLOWING STANDARD PLATES, APPROVED BY THE FEDERAL HIGHWAY ADMINISTRATION, SHALL APPLY ON THIS PROJECT.	
PLATE NO.	DESCRIPTION
3000M	REINFORCED CONCRETE PIPE (5 SHEETS)
3006M	GASKET JOINT FOR R.C. PIPE (2 SHEETS)
4011E	PRECAST CONCRETE BASE
7038A	DETECTABLE WARNING SURFACE TRUNCATED DOMES

EROSION CONTROL NOTES

1. THE CONTRACTOR SHALL INSTALL AND MAINTAIN EROSION CONTROL FENCE AND SEDIMENT CONTROL LOG AS SHOWN AND AS DIRECTED BY ENGINEER IN FIELD. EROSION FENCE AND SEDIMENT CONTROL LOG TO BE REMOVED BY CONTRACTOR AFTER PERMANENT VEGETATION HAS BEEN ESTABLISHED.
2. THE CONTRACTOR SHALL PLACE STORM SEWER STRUCTURE PROTECTION AT CATCH BASINS AS DIRECTED BY ENGINEER TO PREVENT SEDIMENT FROM ENTERING THE STORM SEWER DURING CONSTRUCTION.
3. THE CONTRACTOR SHALL CONSTRUCT AND MAINTAIN ROCK ENTRANCES AT POINTS OF EXIT FROM PAVEMENT AS DIRECTED BY ENGINEER.
4. EROSION CONTROL MUST BE INSTALLED AND INSPECTED PRIOR TO THE START OF LAND DISTURBING ACTIVITIES INCLUDING TREE REMOVAL AND GRADING. - CONTACT CITY OF CHANHASSEN ENGINEERING DEPARTMENT TO SCHEDULE AN INSPECTION - 952-227-1160.
5. THE CONTRACTOR SHALL ABIDE BY ADDITIONAL EROSION AND SEDIMENT CONTROL MEASURES DICTATED BY THE CITY OF CHANHASSEN AND DISTRICT.
6. OPERATIONS MUST BE MANAGED TO ELIMINATE TRACK OUT OF MATERIAL OFFSITE.
7. STRAW MULCH SHALL NOT BE USED FOR TEMPORARY OR FINAL STABILIZATION UNLESS APPROVED BY THE CITY ENGINEER.
8. NATURAL TOPOGRAPHY AND SOIL CONDITIONS MUST BE PROTECTED, INCLUDING RETENTION ONSITE OF NATIVE TOPSOIL TO THE GREATEST EXTENT POSSIBLE.
9. ADDITIONAL MEASURES, SUCH AS HYDRAULIC MULCHING AND OTHER PRACTICES AS SPECIFIED BY THE DISTRICT AND CITY STAFF MUST BE USED ON SLOPES OF 3:1 (H:V) OR STEEPER TO PROVIDE ADEQUATE STABILIZATION.
10. FINAL SITE OF STABILIZATION MEASURES MUST SPECIFY THAT AT LEAST SIX INCHES OF TOPSOIL OR ORGANIC MATTER BE SPREAD AND INCORPORATED INTO THE UNDERLYING SOIL DURING FINAL SITE TREATMENT WHEREVER TOPSOIL HAS BEEN REMOVED.
11. CONSTRUCTION SITE WASTE SUCH AS DISCARDED BUILDING MATERIALS, CONCRETE TRUCK WASHOUT, CHEMICALS, LITTER AND SANITARY WASTE MUST BE PROPERLY MANAGED.
12. ALL TEMPORARY EROSION AND SEDIMENT CONTROL BMPs MUST BE MAINTAINED UNTIL COMPLETION OF CONSTRUCTION AND VEGETATION IS ESTABLISHED SUFFICIENTLY TO ENSURE STABILITY OF THE SITE, AS DETERMINED BY THE WATERSHED DISTRICT AND CITY STAFF.
13. ALL TEMPORARY EROSION AND SEDIMENT CONTROL BMPs MUST BE REMOVED UPON FINAL STABILIZATION.
14. SOIL SURFACES COMPACTED DURING CONSTRUCTION AND REMAINING PVIOUS UPON COMPLETION OF CONSTRUCTION MUST BE DECOMPACTED TO ACHIEVE A SOIL COMPACTION TESTING PRESSURE OF LESS THAN 1,400 KILOPASCALS OR 200 POUNDS PER SQUARE INCH IN THE UPPER 12 INCHES OF SOIL PROFILE WHILE TAKING CARE TO PROTECT UTILITIES, TREE ROOTS, AND OTHER EXISTING VEGETATION.
15. ALL DISTURBED AREAS MUST BE STABILIZED WITHIN 7 CALENDAR DAYS AFTER LAND-DISTURBING WORK HAS TEMPORARILY OR PERMANENTLY CEASED ON A PROPERTY THAT DRAINS TO AN IMPAIRED WATER, WITHIN 14 DAYS ELSEWHERE.
16. THE PERMITEE MUST, AT A MINIMUM, INSPECT, MAINTAIN AND REPAIR ALL DISTURBED SURFACES AND ALL EROSION AND SEDIMENT CONTROL FACILITIES AND SOIL STABILIZATION MEASURES EVER DAY WORK IS PERFORMED ON THE SITE AND AT LEAST WEEKLY UNTIL LAND-DISTURBING ACTIVITY HAS CEASED. THEREAFTER, THE PERMITEE MUST PERFORM THESE RESPONSIBILITIES AT LEAST WEEKLY UNTIL VEGETATIVE COVER IS ESTABLISHED. THE PERMITEE WILL MAINTAIN A LOG OF ACTIVITIES UNDER THIS SECTION FOR INSPECTION BY THE DISTRICT AND CITY ON REQUEST.
17. SODDING TYPE LAWN TO BE USED AT ALL LOCATIONS ADJACENT TO SPRINKLER SYSTEMS. HYDRAULIC MIX/SEEDING TO BE USED IN AREAS OUTSIDE OF SPRINKLER SYSTEMS.

No.	Date	Revisions	App.	DRAWING NAME
				2024_PaveRehab-NOTE.dwg
				DESIGNED BY: MAK
				DRAWN BY: RCH
				CHECKED BY: MAK
				DATE: 02/29/2024
				PROJECT NO. 24-01



11995 SINGLETREE LANE, SUITE 225, EDEN PRAIRIE, MN 55344
PHONE: 612-315-1272
WWW.KIMLEY-HORN.COM

I HEREBY CERTIFY THAT THIS PLAN, SPECIFICATION OR REPORT WAS PREPARED BY ME OR UNDER MY DIRECT SUPERVISION AND THAT I AM A DULY LICENSED PROFESSIONAL ENGINEER UNDER THE LAWS OF THE STATE OF MINNESOTA.

Michael A. Kirsch
MICHAEL A. KIRSCH
DATE: 02/29/2024 MN LIC. NO. 59057



CITY OF CHANHASSEN
2024 CITY PAVEMENT
REHABILITATION PROJECT

GENERAL NOTES

CITY PROJECT	24-01	SHEET NO.
		7
		188

K:\TOW_Civil\City\CHANHASSEN\2024 CITY STREET REHAB-RECONSTRUCT\CAD\Plan Sheets\CHAN-2024-NOTES-GEN.dwg February 29, 2024 - 6:51pm

CHAN VIEW EARTHWORK TAB						
Station	Fill Area	Cut Area	Fill Volume	Cut Volume	Cumulative Fill Vol	Cumulative Cut Vol
1+00.00	0.00	0.00	0.00	0.00	0.00	0.00
1+50.00	0.00	125.24	0.00	115.96	0.00	115.96
2+00.00	0.00	127.45	0.00	233.97	0.00	349.93
2+50.00	0.00	114.81	0.00	224.31	0.00	574.24
3+00.00	0.00	109.78	0.00	207.95	0.00	782.19
3+50.00	0.00	122.91	0.00	215.45	0.00	997.64
4+00.00	0.00	121.02	0.00	225.87	0.00	1223.51
4+50.00	0.00	97.83	0.00	202.64	0.00	1426.14
4+84.17	0.00	125.80	0.00	141.51	0.00	1567.65
5+00.00	0.00	124.69	0.00	72.93	0.00	1640.58
5+50.00	0.00	114.01	0.00	219.61	0.00	1860.19
5+83.51	0.00	119.05	0.00	143.38	0.00	2003.58
6+00.00	0.00	123.25	0.00	73.34	0.00	2076.91
6+33.11	0.00	118.23	0.00	147.02	0.00	2223.93
6+50.00	0.00	119.89	0.00	74.90	0.00	2298.83

CHAN VIEW EARTHWORK TAB						
Station	Fill Area	Cut Area	Fill Volume	Cut Volume	Cumulative Fill Vol	Cumulative Cut Vol
6+95.96	0.00	123.23	0.00	207.33	0.00	2506.16
7+00.00	0.00	122.20	0.00	18.38	0.00	2524.54
7+50.00	0.00	114.80	0.00	219.90	0.00	2744.45
7+58.80	0.00	112.39	0.00	37.25	0.00	2781.69
8+00.00	0.00	84.69	0.00	150.53	0.00	2932.22
8+01.28	0.00	84.39	0.00	4.02	0.00	2936.25
8+43.77	0.47	85.00	0.33	131.28	0.33	3067.53
8+50.00	0.71	84.28	0.14	19.54	0.46	3087.07
9+00.00	1.13	89.89	1.70	161.27	2.16	3248.34
9+50.00	0.00	80.44	1.04	157.71	3.21	3406.05
10+00.00	1.22	97.81	1.13	165.05	4.34	3571.10
10+50.00	0.70	97.85	1.78	181.16	6.11	3752.26
11+00.00	0.29	102.27	0.91	185.29	7.03	3937.56
11+50.00	0.00	77.93	0.27	166.85	7.30	4104.41
12+00.00	0.00	87.81	0.00	153.46	7.30	4257.87

CHAN VIEW EARTHWORK TAB						
Station	Fill Area	Cut Area	Fill Volume	Cut Volume	Cumulative Fill Vol	Cumulative Cut Vol
12+50.00	0.31	105.19	0.28	178.71	7.58	4436.58
13+00.00	0.34	105.42	0.60	195.01	8.18	4631.59
13+50.00	0.00	89.80	0.32	180.76	8.50	4812.35
14+00.00	0.00	92.88	0.00	169.15	8.50	4981.50
14+50.00	0.10	110.92	0.09	188.71	8.59	5170.21
15+00.00	0.00	107.75	0.09	202.48	8.68	5372.68

76TH EARTHWORK TAB						
Station	Fill Area	Cut Area	Fill Volume	Cut Volume	Cumulative Fill Vol	Cumulative Cut Vol
20+10.00	0.00	0.00	0.00	0.00	0.00	0.00
20+50.00	0.00	102.81	0.00	76.15	0.00	76.15
21+00.00	0.00	102.10	0.00	189.73	0.00	265.88
21+50.00	0.00	106.54	0.00	193.19	0.00	459.07
22+00.00	0.00	105.57	0.00	196.40	0.00	655.47
22+50.00	0.00	106.07	0.00	195.96	0.00	851.43
23+00.00	0.00	117.60	0.00	207.10	0.00	1058.54
23+50.00	0.00	91.36	0.00	193.48	0.00	1252.02
24+00.00	0.00	105.77	0.00	182.53	0.00	1434.55
24+50.00	0.00	109.60	0.00	199.42	0.00	1633.97
25+00.00	0.00	113.68	0.00	206.74	0.00	1840.71
25+50.00	0.00	107.74	0.00	205.02	0.00	2045.73
26+00.00	0.00	108.67	0.00	200.37	0.00	2246.10
26+50.00	0.00	109.74	0.00	202.23	0.00	2448.33
27+00.00	0.00	100.82	0.00	194.96	0.00	2643.29

76TH EARTHWORK TAB						
Station	Fill Area	Cut Area	Fill Volume	Cut Volume	Cumulative Fill Vol	Cumulative Cut Vol
27+50.00	0.00	107.07	0.00	192.48	0.00	2835.77
28+00.00	0.00	111.90	0.00	202.75	0.00	3038.52
28+50.00	0.00	110.39	0.00	205.83	0.00	3244.34
29+00.00	0.00	110.95	0.00	204.94	0.00	3449.29
29+50.00	0.00	106.29	0.00	201.14	0.00	3650.43
30+00.00	0.00	95.99	0.00	187.29	0.00	3837.72
30+50.00	0.00	98.41	0.00	180.00	0.00	4017.72
31+00.00	0.00	107.50	0.00	190.65	0.00	4208.37
31+50.00	0.00	107.94	0.00	199.48	0.00	4407.85
32+00.00	0.00	105.11	0.00	197.27	0.00	4605.12
32+50.00	0.00	112.48	0.00	201.48	0.00	4806.60
33+00.00	0.04	107.63	0.04	203.81	0.04	5010.41
33+48.55	0.00	0.00	0.04	96.77	0.08	5107.18

KIOWA EARTHWORK TAB						
Station	Fill Area	Cut Area	Fill Volume	Cut Volume	Cumulative Fill Vol	Cumulative Cut Vol
200+00.00	0.00	0.00	0.00	0.00	0.00	0.00
200+50.00	0.00	118.27	0.00	109.51	0.00	109.51
201+00.00	0.00	101.26	0.00	203.27	0.00	312.78
201+50.00	0.00	102.06	0.00	188.26	0.00	501.04
202+00.00	0.00	103.86	0.00	190.66	0.00	691.71
202+50.00	0.00	106.06	0.00	194.37	0.00	886.07
203+00.00	0.00	106.70	0.00	197.00	0.00	1083.07
203+50.00	0.00	111.52	0.00	202.05	0.00	1285.12
204+00.00	0.00	106.45	0.00	201.82	0.00	1486.94
204+50.00	0.00	107.84	0.00	198.41	0.00	1685.35
205+00.00	0.00	108.32	0.00	200.15	0.00	1885.50
205+50.00	0.00	103.30	0.00	195.95	0.00	2081.44
206+00.00	0.00	105.21	0.00	193.06	0.00	2274.50
206+50.00	0.00	104.88	0.00	194.53	0.00	2469.03
207+00.00	0.00	101.55	0.00	191.13	0.00	2660.17

KIOWA EARTHWORK TAB						
Station	Fill Area	Cut Area	Fill Volume	Cut Volume	Cumulative Fill Vol	Cumulative Cut Vol
207+40.50	0.00	0.00	0.00	76.16	0.00	2736.33

No.	Date	Revisions	App.

DRAWING NAME	CHAN-2024-NOTES-GEN.dwg
DESIGNED BY:	MAK
DRAWN BY:	RCH
CHECKED BY:	MAK
DATE:	02/29/2024
PROJECT NO.	24-01

Kimley»Horn

11995 SINGLETREE LANE, SUITE 225, EDEN PRAIRIE, MN 55344
 PHONE: 612-315-1272
 WWW.KIMLEY-HORN.COM

I HEREBY CERTIFY THAT THIS PLAN, SPECIFICATION OR REPORT WAS PREPARED BY ME OR UNDER MY DIRECT SUPERVISION AND THAT I AM A DULY LICENSED PROFESSIONAL ENGINEER UNDER THE LAWS OF THE STATE OF MINNESOTA.

Michael A. Kirsch
 MICHAEL A. KIRSCH
 DATE: 02/29/2024 MN LIC. NO. 59057



CITY OF CHANHASSEN
 2024 CITY PAVEMENT REHABILITATION PROJECT

EARTHWORK SUMMARY

CITY PROJECT	24-01
SHEET NO.	8

188

K:\TOW_Civil\CITY\CHANHASSEN\2024 CITY STREET REHAB-RECONSTRUCT\CAD\Plan Sheets\CHAN-2024-NOTES-GEN.dwg February 29, 2024 - 6:51pm

IROQUOIS EARTHWORK TAB						
Station	Fill Area	Cut Area	Fill Volume	Cut Volume	Cumulative Fill Vol	Cumulative Cut Vol
220+00.00	0.00	0.00	0.00	0.00	0.00	0.00
220+50.00	0.00	105.99	0.00	98.14	0.00	98.14
221+00.00	0.00	105.35	0.00	195.68	0.00	293.82
221+50.00	0.00	109.11	0.00	198.57	0.00	492.39
222+00.00	0.00	105.90	0.00	199.08	0.00	691.47
222+50.00	0.00	116.88	0.00	206.28	0.00	897.75
223+00.00	0.00	112.49	0.00	212.38	0.00	1110.13
223+50.00	0.00	116.92	0.00	212.41	0.00	1322.55
224+00.00	0.00	116.45	0.00	216.08	0.00	1538.63
224+50.00	0.00	115.68	0.00	214.94	0.00	1753.57
225+00.00	0.00	112.37	0.00	211.15	0.00	1964.72
225+50.00	0.00	106.91	0.00	203.03	0.00	2167.76
226+00.00	0.00	188.15	0.00	273.20	0.00	2440.96
226+16.23	0.00	0.00	0.00	56.55	0.00	2497.51

HURON EARTHWORK TAB						
Station	Fill Area	Cut Area	Fill Volume	Cut Volume	Cumulative Fill Vol	Cumulative Cut Vol
260+00.00	0.00	0.00	0.00	0.00	0.00	0.00
260+50.00	0.00	103.75	0.00	96.07	0.00	96.07
261+00.00	0.00	104.93	0.00	193.22	0.00	289.29
261+50.00	0.00	105.13	0.00	194.50	0.00	483.79
262+00.00	0.00	105.35	0.00	194.89	0.00	678.68
262+50.00	0.00	112.22	0.00	201.46	0.00	880.14
263+00.00	0.00	111.09	0.00	206.77	0.00	1086.91
263+50.00	0.00	106.82	0.00	201.77	0.00	1288.68
264+00.00	0.00	108.09	0.00	198.99	0.00	1487.67
264+50.00	0.00	100.08	0.00	192.75	0.00	1680.41
265+00.00	0.00	104.93	0.00	189.82	0.00	1870.23
265+50.00	0.00	102.57	0.00	192.13	0.00	2062.35
266+00.00	0.00	105.85	0.00	192.98	0.00	2255.33
266+50.00	0.00	105.00	0.00	195.23	0.00	2450.56
266+96.83	0.00	0.00	0.00	91.05	0.00	2541.61

77TH EARTHWORK TAB						
Station	Fill Area	Cut Area	Fill Volume	Cut Volume	Cumulative Fill Vol	Cumulative Cut Vol
280+00.00	0.00	0.00	0.00	0.00	0.00	0.00
280+50.00	0.00	105.55	0.00	97.73	0.00	97.73
281+00.00	0.00	110.04	0.00	199.63	0.00	297.36
281+50.00	0.00	104.71	0.00	198.84	0.00	496.20
282+00.00	0.00	102.33	0.00	191.70	0.00	687.90
282+50.00	0.00	100.32	0.00	187.63	0.00	875.54
283+00.00	0.00	100.01	0.00	185.49	0.00	1061.02
283+50.00	0.00	101.28	0.00	186.38	0.00	1247.41
284+00.00	0.00	114.95	0.00	200.22	0.00	1447.63
284+50.00	0.00	107.49	0.00	205.96	0.00	1653.59
284+67.53	0.00	105.41	0.00	69.12	0.00	1722.71

GREAT PLAINS EARTHWORK TAB						
Station	Fill Area	Cut Area	Fill Volume	Cut Volume	Cumulative Fill Vol	Cumulative Cut Vol
300+00.00	0.00	0.00	0.00	0.00	0.00	0.00
300+50.00	0.00	124.48	0.00	115.26	0.00	115.26
301+00.00	0.00	123.79	0.00	229.88	0.00	345.13
301+50.00	0.00	125.67	0.00	230.98	0.00	576.12
302+00.00	0.00	120.99	0.00	228.40	0.00	804.51
302+50.00	0.00	125.73	0.00	228.45	0.00	1032.96
303+00.00	0.00	120.86	0.00	228.33	0.00	1261.29
303+50.00	0.00	121.73	0.00	224.62	0.00	1485.91
304+00.00	0.00	101.93	0.00	207.09	0.00	1693.00
304+50.00	0.00	128.45	0.00	213.31	0.00	1906.31
304+85.86	0.00	118.95	0.00	164.28	0.00	2070.59
304+94.18	0.00	116.19	0.00	36.15	0.00	2106.73
305+00.00	0.00	114.99	0.00	24.81	0.00	2131.55
305+02.51	0.00	114.49	0.00	10.67	0.00	2142.22
305+36.81	0.01	104.47	0.01	139.09	0.01	2281.31

GREAT PLAINS EARTHWORK TAB						
Station	Fill Area	Cut Area	Fill Volume	Cut Volume	Cumulative Fill Vol	Cumulative Cut Vol
305+44.95	0.01	102.48	0.00	31.17	0.01	2312.48
305+50.00	0.01	102.25	0.00	19.16	0.02	2331.64
305+53.08	0.01	102.02	0.00	11.64	0.02	2343.28
306+00.00	0.00	100.62	0.01	176.08	0.03	2519.36
306+50.00	0.07	107.81	0.06	192.99	0.09	2712.35
307+00.00	0.29	101.92	0.33	194.20	0.42	2906.55
307+50.00	0.00	98.96	0.27	186.00	0.69	3092.55
308+00.00	0.20	108.51	0.19	192.10	0.88	3284.65
308+50.00	0.17	100.80	0.34	193.80	1.22	3478.45
309+00.00	0.00	109.04	0.16	194.29	1.38	3672.74
309+50.00	0.00	105.82	0.00	198.94	1.38	3871.69
310+00.00	0.00	104.99	0.00	195.19	1.38	4066.88
310+50.00	0.00	104.66	0.00	194.12	1.38	4261.00
311+00.00	0.00	106.33	0.00	195.36	1.38	4456.36
311+50.00	0.00	99.94	0.00	190.98	1.38	4647.34

GREAT PLAINS EARTHWORK TAB						
Station	Fill Area	Cut Area	Fill Volume	Cut Volume	Cumulative Fill Vol	Cumulative Cut Vol
311+84.91	0.00	99.78	0.00	129.10	1.38	4776.44
311+95.50	0.00	102.43	0.00	40.00	1.38	4816.44
312+00.00	0.00	102.21	0.00	17.05	1.38	4833.49
312+06.09	0.00	102.17	0.00	23.29	1.38	4856.78
312+50.00	0.74	108.45	0.60	171.24	1.98	5028.02
313+00.00	0.14	114.22	0.81	206.17	2.79	5234.20
313+30.38	0.00	117.91	0.08	130.59	2.86	5364.79
313+40.27	0.00	117.95	0.00	43.16	2.86	5407.96
313+50.00	0.00	118.88	0.00	42.65	2.86	5450.60
313+50.15	0.00	118.90	0.00	0.66	2.86	5451.27
314+00.00	0.00	120.26	0.00	220.78	2.86	5672.04
314+50.00	0.00	123.31	0.00	225.53	2.86	5897.58
314+97.10	0.00	0.00	0.00	107.56	2.86	6005.13

No.	Date	Revisions	App.	DRAWING NAME
				CHAN-2024-NOTES-GEN.dwg
				DESIGNED BY: MAK
				DRAWN BY: RCH
				CHECKED BY: MAK
				DATE: 02/29/2024
				PROJECT NO. 24-01



11995 SINGLETREE LANE, SUITE 225, EDEN PRAIRIE, MN 55344
 PHONE: 612-315-1272
 WWW.KIMLEY-HORN.COM

I HEREBY CERTIFY THAT THIS PLAN, SPECIFICATION OR REPORT WAS PREPARED BY ME OR UNDER MY DIRECT SUPERVISION AND THAT I AM A DULY LICENSED PROFESSIONAL ENGINEER UNDER THE LAWS OF THE STATE OF MINNESOTA.

Michael A. Kirsch
 MICHAEL A. KIRSCH
 DATE: 02/29/2024 MN LIC. NO. 59057



CITY OF CHANHASSEN
 2024 CITY PAVEMENT
 REHABILITATION PROJECT

EARTHWORK SUMMARY

CITY PROJECT 24-01

SHEET NO.

9

188

EARTHWORK SUMMARY NOTES:

- EXCAVATION VOLUMES SHOWN THIS SHEET DO NOT INCLUDE ADDITIONAL TOPSOIL STRIPPING NECESSARY PRIOR TO ROADWAY CONSTRUCTION. TOPSOIL DEPTHS ARE ESTIMATED AS 6" WITHIN THE PROJECT AREA.
- EMBANKMENT VOLUMES SHOWN THIS SHEET DO NOT INCLUDE TOPSOIL PLACEMENT. EMBANKMENT VOLUMES SHOWN THIS SHEET DO NOT INCLUDE ADDITIONAL IMPORT FILL MATERIAL VOLUME TO REPLACE STRIPPED TOPSOIL. EMBANKMENT VOLUMES REPRESENT THE VOLUME BETWEEN BOTTOM OF PAVEMENT SECTION AND EXISTING GROUND.
- EMBANKMENT QUANTITIES SHOWN IN THE VOLUME TABLES ASSUME 0% SHRINKAGE FACTOR.
- CHAN VIEW EARTHWORK TABULATIONS INCLUDE COMMON EMBANKMENT AND COMMON EXCAVATION FOR BID ALTERNATIVE 2 (CHAN VIEW SIDEWALK).

EARTHWORK SUMMARY:



<u>EXCAVATION:</u>		<u>EMBANKMENT:</u>	
ROADWAY EXCAVATION (1):	26,014 CU YD	ROADWAY EMBANKMENT (2):	12 CU YD
BMP EXCAVATION(4):	456 CU YD		
PAVEMENT REMOVAL VOLUME (3):	10,200 CU YD	<u>TOTAL COMMON EMBANKMENT:</u>	<u>12 CU YD</u>
<u>TOTAL COMMON EXCAVATION:</u>		<u>16,270 CU YD</u>	

- (1): CUMULATIVE CUT VOLUME, AS SHOWN IN EARTHWORK TABS ON PREVIOUS SHEETS
 (2): CUMULATIVE FILL VOLUME, AS SHOWN IN EARTHWORK TABS ON PREVIOUS SHEETS
 (3): PAVEMENT REMOVAL VOLUME SUBTRACTED FROM COMMON EXCAVATION: ASSUMED 10" EXISTING PAVEMENT DEPTH.
 (4): BMP EXCAVATION IS FOR RAIN GARDENS, SEE RAIN GARDEN DETAIL SHEETS.
 (5): SEE POND CLEAN OUT SHEETS FOR POND EXCAVATION. POND EXCAVATION PAID FOR UNDER 2105.601 CHANNEL AND POND EXCAVATION

EARTHWORK NOTES:

- EMBANKMENT QUANTITIES ASSUME 0% SHRINKAGE FACTOR.
- EARTHWORK QUANTITIES DO NOT INCLUDE PAVEMENT REMOVALS.
- COMMON EXCAVATION WAS CALCULATED BASED ON ASSUMED 10" BITUMINOUS ROADWAY, 4" DRIVEWAYS, AND 3" TRAILS AND 6" SIDEWALK REMOVAL DEPTHS.
- COMMON EXCAVATION QUANTITY INCLUDES REMOVAL OF TOPSOIL.
- SEE CROSS SECTIONS FOR SUBCUT DEPTH AND LOCATIONS. SUBCUT QUANTITIES ARE INCLUDED IN COMMON EXCAVATION. ADDITIONAL SUBGRADE CORRECTIONS, IF REQUIRED, WILL BE DESIGNATED BY THE ENGINEER AND PAID FOR AS COMMON EXCAVATION UNLESS ANOTHER PAY ITEM FOR SOIL CORRECTION IS PROVIDED.
- ALL SHAPING AROUND CULVERT ENDS AND STORM SEWER INLETS & OUTLETS, AS DIRECTED BY THE ENGINEER, WILL BE CONSIDERED INCIDENTAL.
- NO WORK, INCLUDING THE STOCKPILING OF TOPSOIL, SHALL EXTEND BEYOND THE RIGHT-OF-WAY, TEMPORARY EASEMENT, OR THE DRAINAGE & UTILITY EASEMENT UNLESS THE CONTRACTOR HAS PROVIDED THE CITY WITH A COPY OF THE OWNERS WRITTEN PERMISSION FOR SUCH WORK.

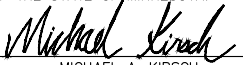
K:\TOW_Civil\CITY OF CHANHASSEN\2024 CITY STREET REHAB-RECONSTRUCT\CAD\Plan Sheets\CHAN-2024-NOTES-GEN.dwg February 29, 2024 - 6:52pm

No.	Date	Revisions	App.	DRAWING NAME CHAN-2024-NOTES-GEN.dwg	 11995 SINGLETREE LANE, SUITE 225, EDEN PRAIRIE, MN 55344 PHONE: 612-315-1272 WWW.KIMLEY-HORN.COM	I HEREBY CERTIFY THAT THIS PLAN, SPECIFICATION OR REPORT WAS PREPARED BY ME OR UNDER MY DIRECT SUPERVISION AND THAT I AM A DULY LICENSED PROFESSIONAL ENGINEER UNDER THE LAWS OF THE STATE OF MINNESOTA.  MICHAEL A. KIRSCH DATE: 02/29/2024 MN LIC. NO. 59057		CITY OF CHANHASSEN 2024 CITY PAVEMENT REHABILITATION PROJECT	CITY PROJECT	24-01	SHEET NO. 10			
										EARTHWORK SUMMARY				188

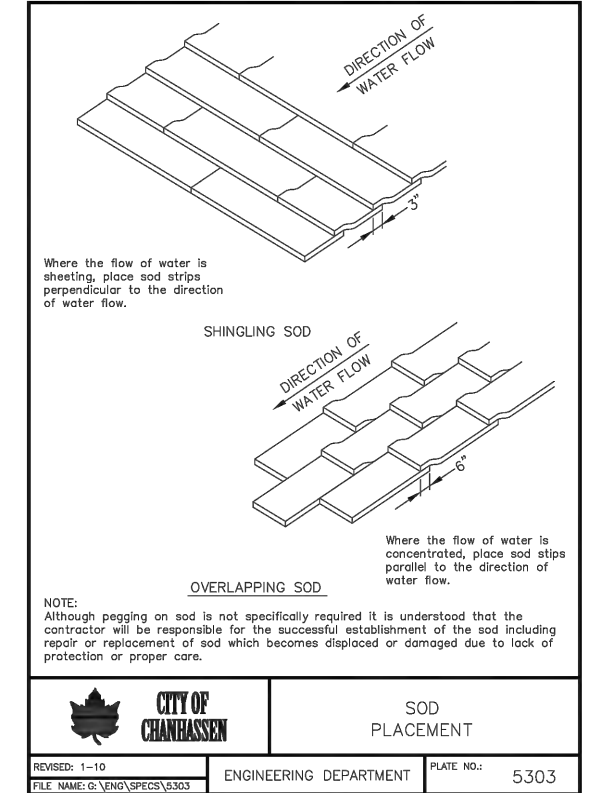
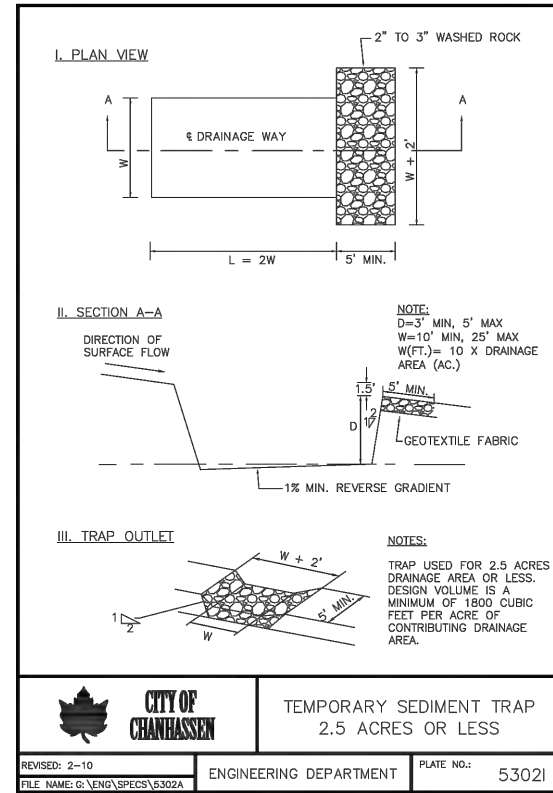
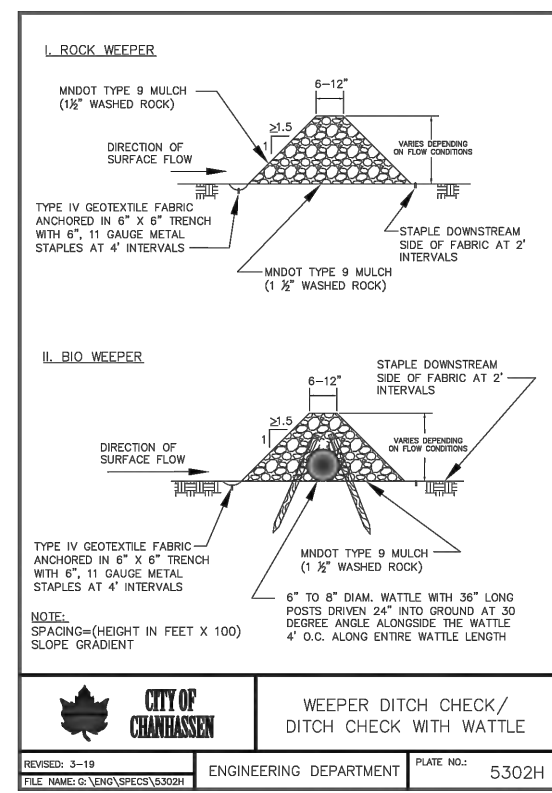
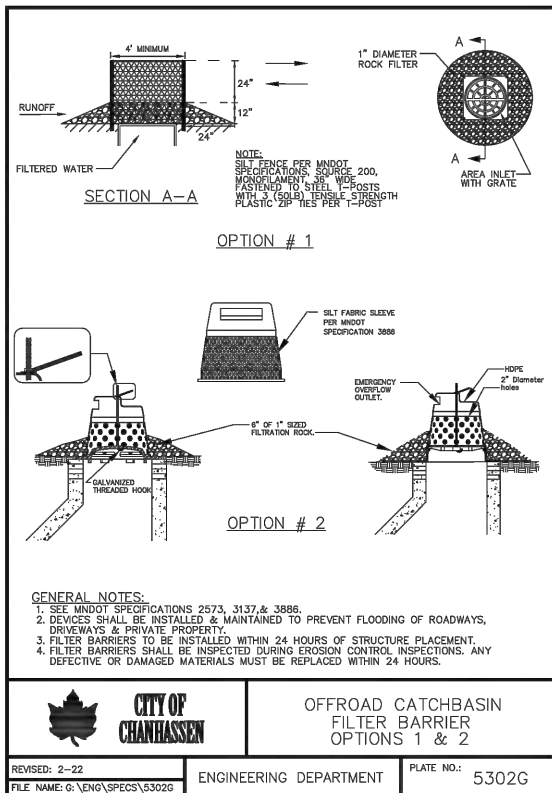
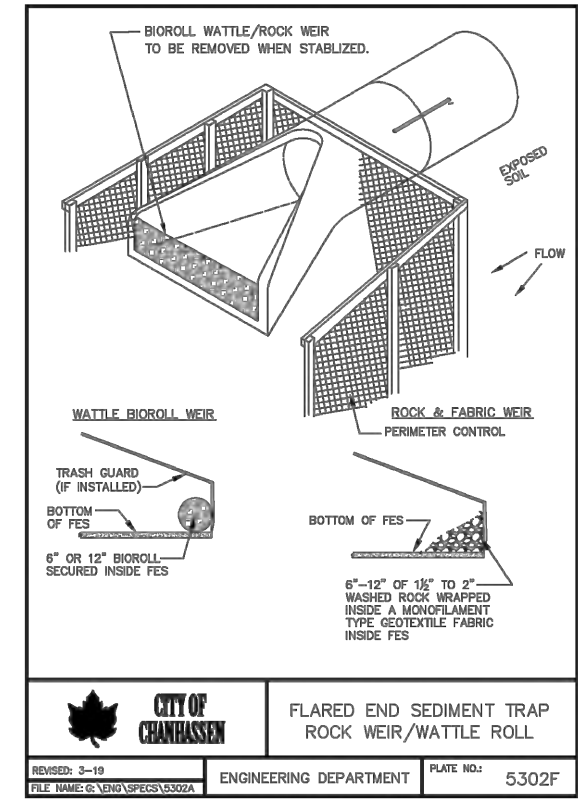
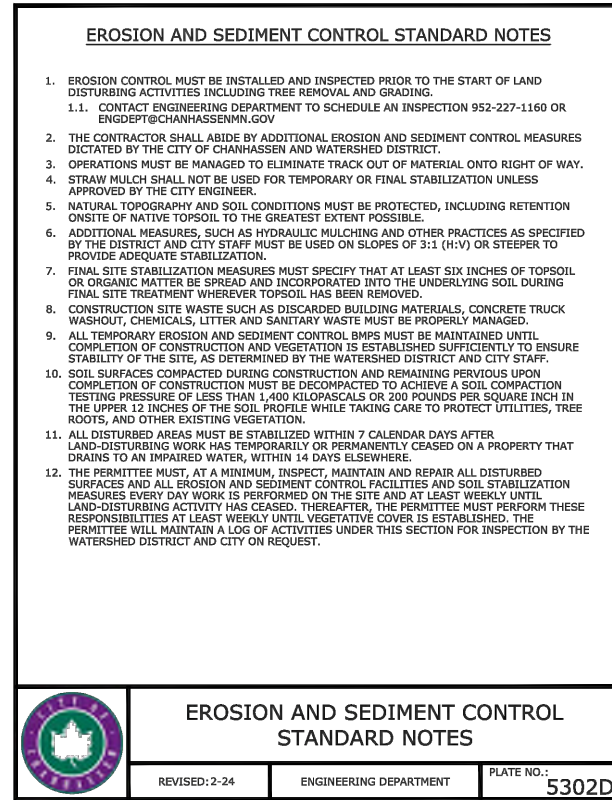
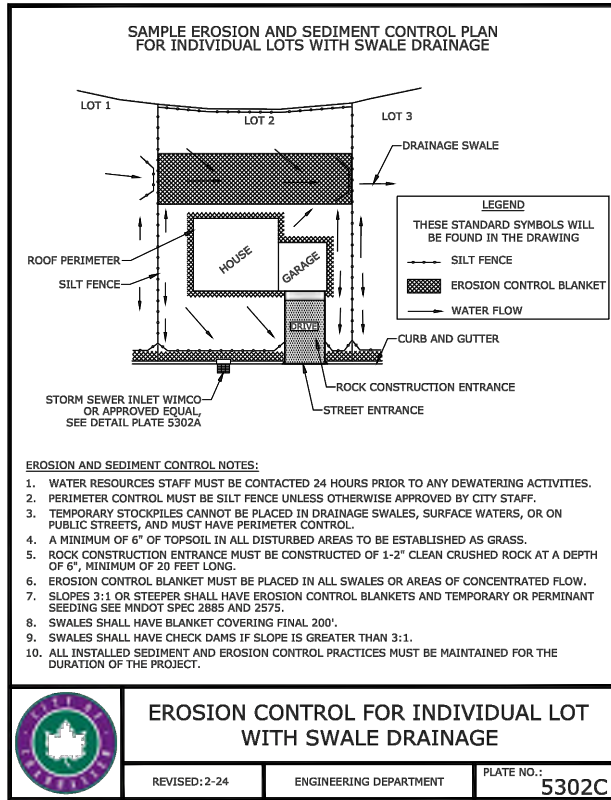
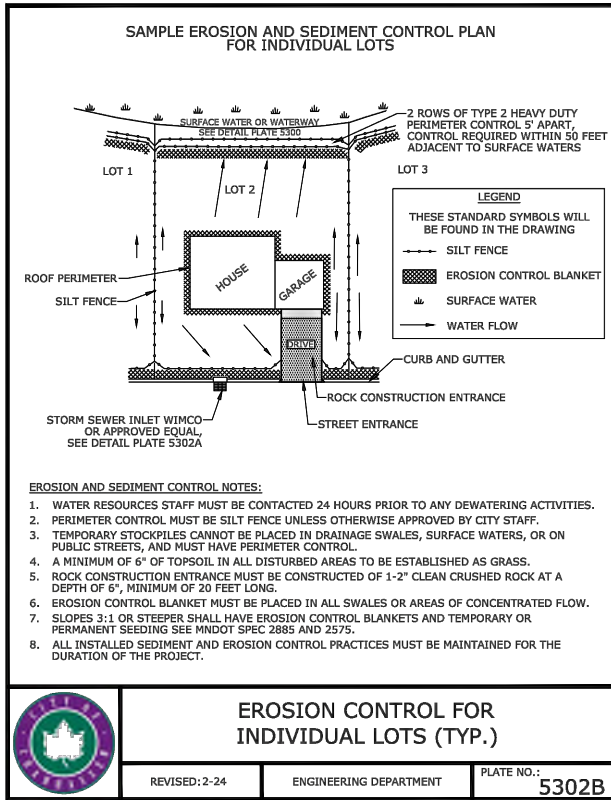

C:\Users\REED~1\HED\AppData\Local\Temp\AcPublish_28308\2024_PaveRehab_PLTS.dwg March 05, 2024 - 9:00am

No.	Date	Revisions	App.	DRAWING NAME
				2024_PaveRehab_PLTS.dwg
				DESIGNED BY: MAK
				DRAWN BY: RCH
				CHECKED BY: MAK
				DATE: 02/29/2024
				PROJECT NO. 24-01

Kimley»Horn

11995 SINGLETREE LANE, SUITE 225, EDEN PRAIRIE, MN 55344
PHONE: 612-315-1272
WWW.KIMLEY-HORN.COM

CITY OF CHANHASSEN
2024 CITY PAVEMENT
REHABILITATION PROJECT

STANDARD PLATES

CITY PROJECT 24-01

SHEET NO. 24

188



CITY OF CHANHASSEN

REVISED: 1-10

FILE NAME: G:\ENR\SPCS\5311

ENGINEERING DEPARTMENT

PLATE: 5312

PLANTING DETAIL

PLANTING SOIL

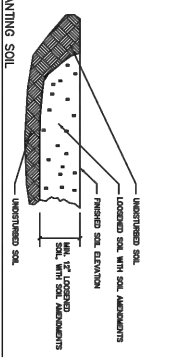

12" LOOSE SOIL WITH SOIL AMENDMENTS
12" LOOSE SOIL WITH SOIL AMENDMENTS
12" LOOSE SOIL WITH SOIL AMENDMENTS

STAKING / CUTTING DETAIL

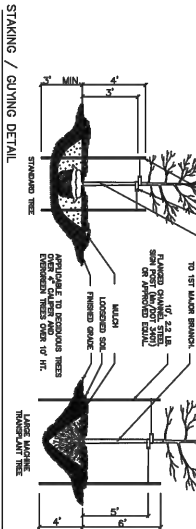

STAKING / CUTTING DETAIL

SEEDLING TREE SHELTER DETAIL

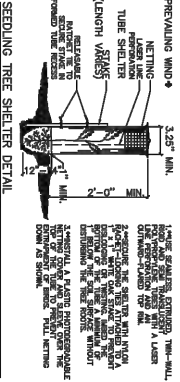

3.00\" MAX.
VENTILATING SCREEN
TILT SCREEN
(LENGTH VARIES)
1\" MIN.
1\" MIN.
1\" MIN.

RODENT PROTECTION DETAIL (OPTION 1)

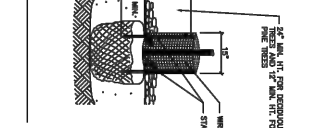

1\" MIN.
1\" MIN.
1\" MIN.

RODENT PROTECTION DETAIL (OPTION 2)

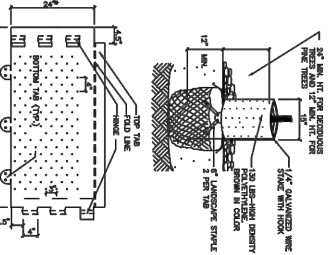

1\" MIN.
1\" MIN.
1\" MIN.

PLANTING SOIL



12\" LOOSE SOIL WITH SOIL AMENDMENTS
12\" LOOSE SOIL WITH SOIL AMENDMENTS
12\" LOOSE SOIL WITH SOIL AMENDMENTS

STAKING / CUTTING DETAIL



STAKING / CUTTING DETAIL

GENERAL NOTES

SEE SPECIAL PROVISIONS FOR SPECIFIC PROJECT REQUIREMENTS.

1. THE PLANTING SOIL SHALL BE A MINIMUM OF 12\"

2. THE PLANTING SOIL SHALL BE A MINIMUM OF 12\"

3. THE PLANTING SOIL SHALL BE A MINIMUM OF 12\"

4. THE PLANTING SOIL SHALL BE A MINIMUM OF 12\"

5. THE PLANTING SOIL SHALL BE A MINIMUM OF 12\"

6. THE PLANTING SOIL SHALL BE A MINIMUM OF 12\"

7. THE PLANTING SOIL SHALL BE A MINIMUM OF 12\"

8. THE PLANTING SOIL SHALL BE A MINIMUM OF 12\"

9. THE PLANTING SOIL SHALL BE A MINIMUM OF 12\"

10. THE PLANTING SOIL SHALL BE A MINIMUM OF 12\"



CITY OF CHANHASSEN

REVISED: 2-10

FILE NAME: G:\ENR\SPCS\5312

ENGINEERING DEPARTMENT

PLATE: 5312

VEGETATION PROTECTION DETAIL

PRUNING DETAILS (Slope Method)

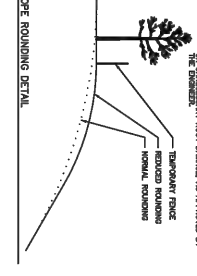

1\" MIN.
1\" MIN.
1\" MIN.

PRUNING DETAILS (Slope Method)

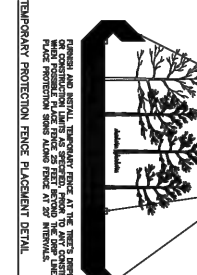

1\" MIN.
1\" MIN.
1\" MIN.

ROOT SYSTEM BRIDGE AND VIBRATORY FLOW

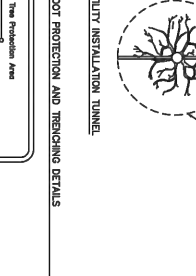

1\" MIN.
1\" MIN.
1\" MIN.

ROOT SYSTEM BRIDGE AND VIBRATORY FLOW

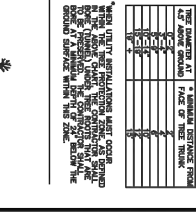

1\" MIN.
1\" MIN.
1\" MIN.

VEGETATION PROTECTION DETAIL



1\" MIN.
1\" MIN.
1\" MIN.

VEGETATION PROTECTION DETAIL



1\" MIN.
1\" MIN.
1\" MIN.

No.	Date	Revisions	App.	DRAWING NAME
				2024_PaveRehab_PLTS.dwg
				DESIGNED BY: MAK
				DRAWN BY: RCH
				CHECKED BY: MAK
				DATE: 02/29/2024
				PROJECT NO. 24-01

Kimley»Horn

11995 SINGLETREE LANE, SUITE 225, EDEN PRAIRIE, MN 55344
PHONE: 612-315-1272
WWW.KIMLEY-HORN.COM



CITY OF CHANHASSEN
2024 CITY PAVEMENT
REHABILITATION PROJECT

STANDARD PLATES

CITY PROJECT	24-01	SHEET NO.
		28
		188

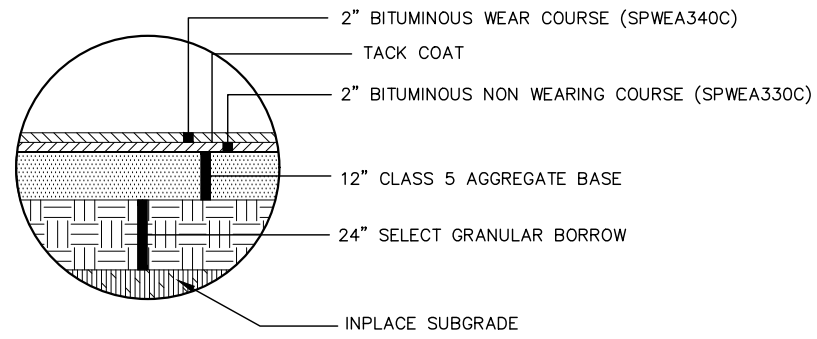

INSET A – BITUMINOUS ROADWAY

FULL DEPTH RECONSTRUCTION
(CHAN VIEW AREA, GREAT PLAINS BOULEVARD, 77TH AND 76TH STREETS)

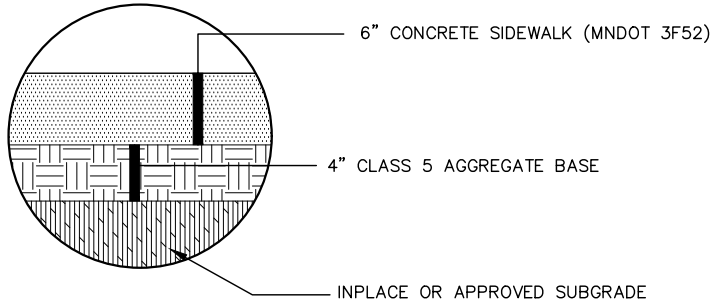

INSET E – CONCRETE SIDEWALK

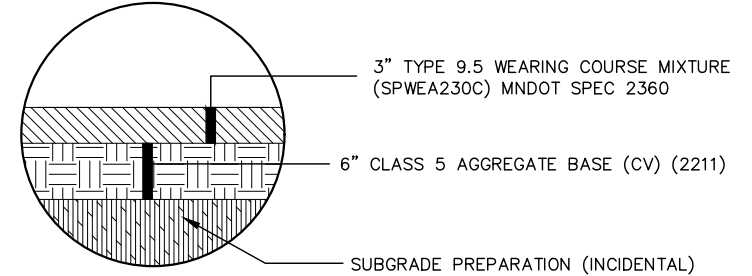

INSET F – BITUMINOUS DRIVEWAY PAVEMENT

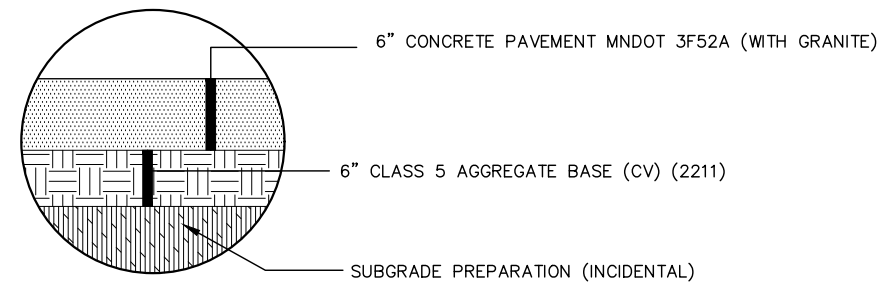

INSET G – CONCRETE DRIVEWAY PAVEMENT

GENERAL NOTES:

1. ALL CURB AND GUTTER IS SURMOUNTABLE UNLESS OTHERWISE NOTED.
2. DIMENSIONS ARE TO THE FACE OF CURB UNLESS OTHERWISE NOTED. B.O.C.: BACK OF CURB. F.O.C.: FACE OF CURB
3. SPOT CURB & GUTTER REPLACEMENT TO BE IDENTIFIED AND MARKED BY THE FIELD ENGINEER.
4. SPOT CONCRETE WALK REPLACEMENT TO BE IDENTIFIED AND MARKED BY THE FIELD ENGINEER.
5. FIELD ENGINEER TO IDENTIFY DRIVEWAY REMOVAL AND REPLACEMENTS.
6. MNDOT SEED MIX 25-151 TO BE USED AT ALL DISTURBED TURF AREAS WITH MINIMUM 6" TOPSOIL.
(SEE GENERAL NOTES – SHEET 7 FOR APPLICATION RATES)
7. EXISTING CROWN SLOPE VARIES, CONTRACTOR SHALL GRADE EXISTING AGGREGATE BASE AND RECLAIMED BASE MATERIALS TO CONSTRUCT A 2% CROWN ON ALL STREET. GRADING OF THE EXISTING AGGREGATE BASE/SUBGRADE AND RECLAIMED BASE MATERIALS IS PAID AS SUBGRADE PREPARATION PER SQUARE YARD.
8. ALL GRADES ARE SHOWN AS FT:FT, HORIZONTAL:VERTICAL.
9. UTILITY REPLACEMENTS THAT REQUIRE FULL DEPTH RECONSTRUCTION SHALL BE REPLACED WITH PAVEMENT SECTION INSET A AND SHALL BE INCIDENTAL

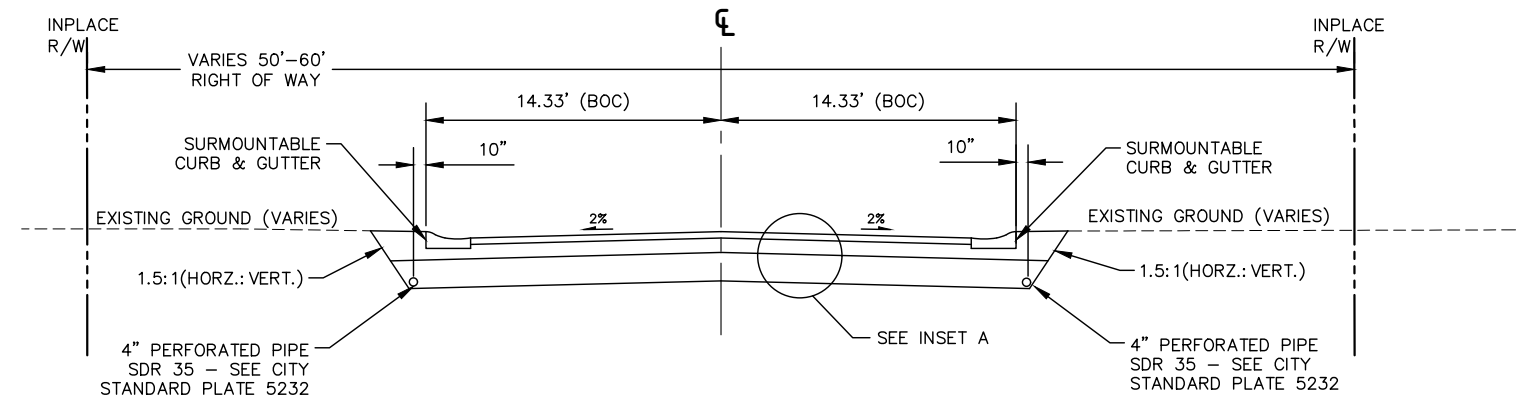

PROPOSED TYPICAL SECTION

FULL DEPTH RECONSTRUCTION
(GREAT PLAINS BOULEVARD, 77TH, 76TH, & IROQUOIS STREETS, HURON & KIOWA AVENUES)

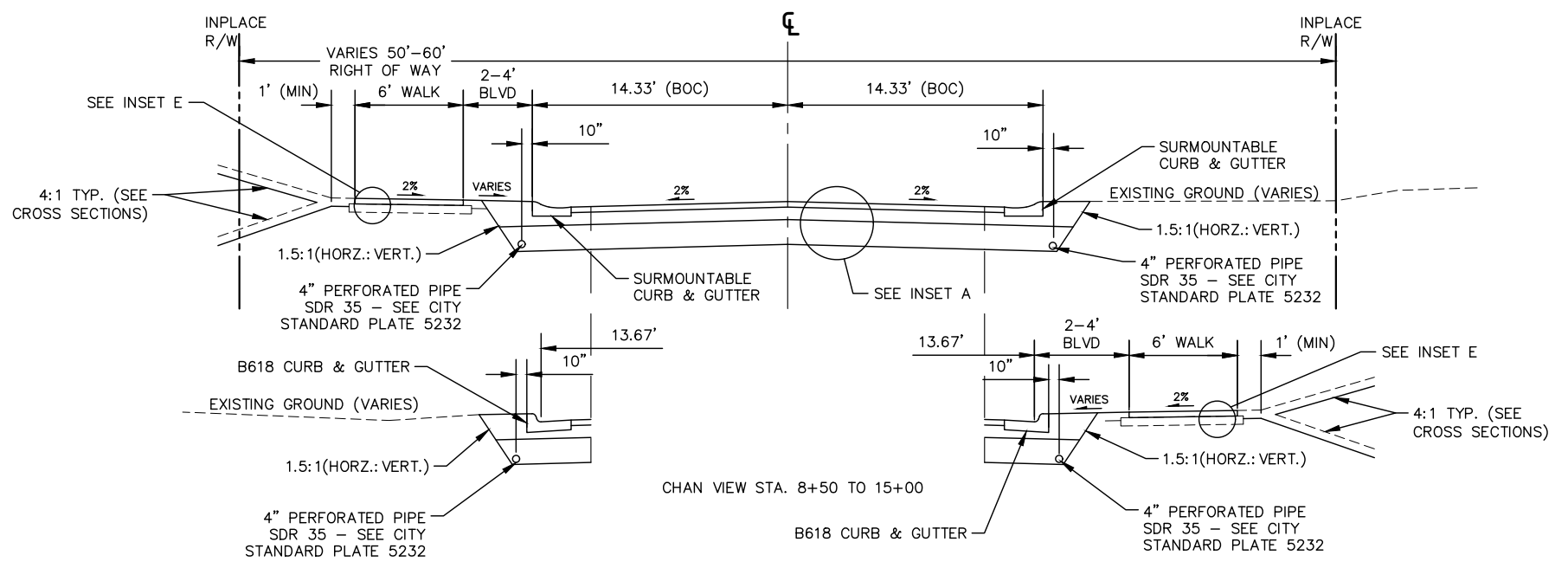

PROPOSED TYPICAL SECTION

FULL DEPTH RECONSTRUCTION (CHAN VIEW STA. 1+00 TO 8+50)

K:\TOW_Civil\City\CHANHASSEN\2024\CITY STREET REHAB-RECONSTRUCT\CAD\Plan Sheets\2024-PaveRehab-TYP.dwg February 29, 2024 - 6:54pm

No.	Date	Revisions	App.	DRAWING NAME
				2024-PaveRehab-TYP.dwg
				DESIGNED BY: MAK
				DRAWN BY: RCH
				CHECKED BY: MAK
				DATE: 02/29/2024
				PROJECT NO. 24-01

Kimley»Horn
11995 SINGLETREE LANE, SUITE 225, EDEN PRAIRIE, MN 55344
PHONE: 612-315-1272
WWW.KIMLEY-HORN.COM

I HEREBY CERTIFY THAT THIS PLAN, SPECIFICATION OR REPORT WAS PREPARED BY ME OR UNDER MY DIRECT SUPERVISION AND THAT I AM A DULY LICENSED PROFESSIONAL ENGINEER UNDER THE LAWS OF THE STATE OF MINNESOTA.
Michael A. Kirsch
MICHAEL A. KIRSCH
DATE: 02/29/2024 MN LIC. NO. 59057



CITY OF CHANHASSEN
2024 CITY PAVEMENT REHABILITATION PROJECT
TYPICAL SECTIONS

CITY PROJECT 24-01
SHEET NO. 29

188

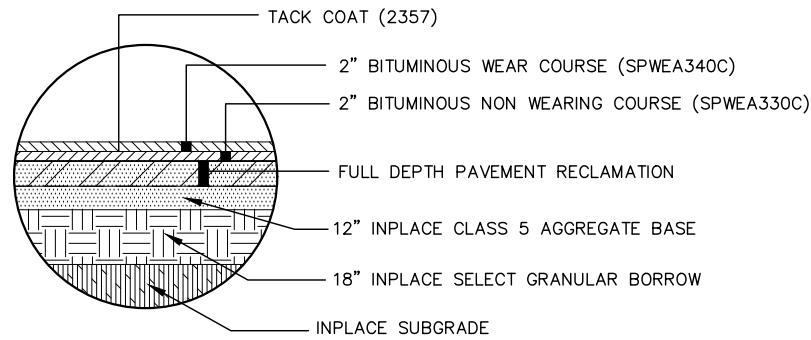

INSET B – BITUMINOUS ROADWAY
FULL DEPTH RECLAMATION
(STONE CREEK AREA)

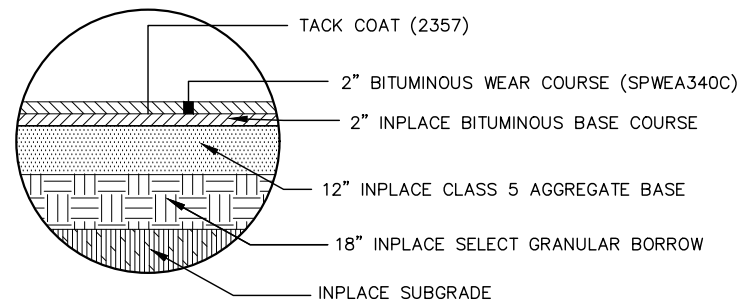

INSET C – BITUMINOUS ROADWAY
2" MILL & OVERLAY (SANTA FE, DEL RIO)

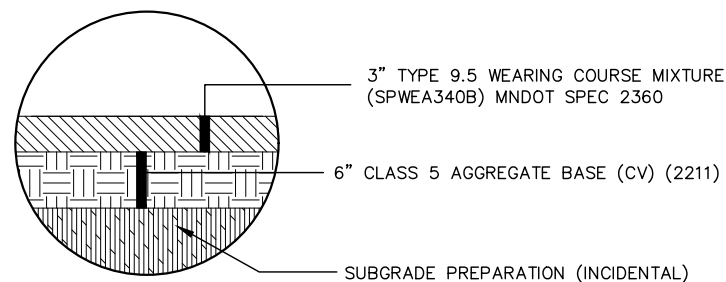

INSET H – BITUMINOUS TRAIL

GENERAL NOTES:

1. ALL CURB AND GUTTER IS SURMOUNTABLE UNLESS OTHERWISE NOTED.
2. DIMENSIONS ARE TO THE FACE OF CURB UNLESS OTHERWISE NOTED. B.O.C.: BACK OF CURB. F.O.C.: FACE OF CURB
3. SPOT CURB & GUTTER REPLACEMENT TO BE IDENTIFIED AND MARKED BY THE FIELD ENGINEER.
4. SPOT CONCRETE WALK REPLACEMENT TO BE IDENTIFIED AND MARKED BY THE FIELD ENGINEER.
5. FIELD ENGINEER TO IDENTIFY DRIVEWAY REMOVAL AND REPLACEMENTS.
6. MNDOT SEED MIX 25-151 TO BE USED AT ALL DISTURBED TURF AREAS WITH MINIMUM 6" TOPSOIL.
(SEE GENERAL NOTES – SHEET 7 FOR APPLICATION RATES)
7. EXISTING CROWN SLOPE VARIES, CONTRACTOR SHALL GRADE EXISTING AGGREGATE BASE AND RECLAIMED BASE MATERIALS TO CONSTRUCT A 2% CROWN ON ALL STREET. GRADING OF THE EXISTING AGGREGATE BASE/SUBGRADE AND RECLAIMED BASE MATERIALS IS PAID AS SUBGRADE PREPARATION PER SQUARE YARD.
8. ALL GRADES ARE SHOWN AS FT:FT, HORIZONTAL:VERTICAL.
9. UTILITY REPLACEMENTS THAT REQUIRE FULL DEPTH RECONSTRUCTION SHALL BE REPLACED WITH PAVEMENT SECTION INSET A AND SHALL BE INCIDENTAL

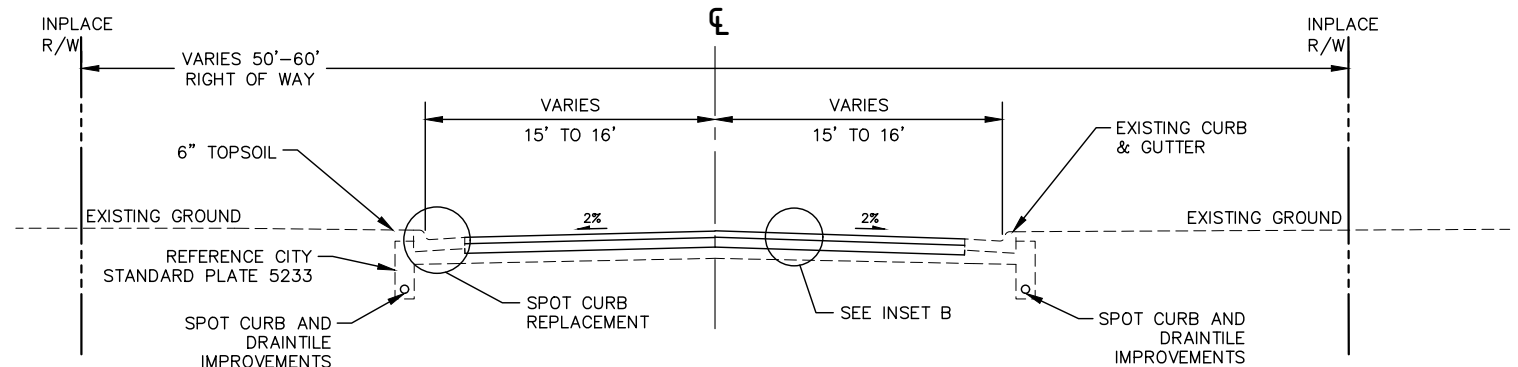

PROPOSED TYPICAL SECTION
FULL DEPTH RECLAMATION
(STONE CREEK AREA)

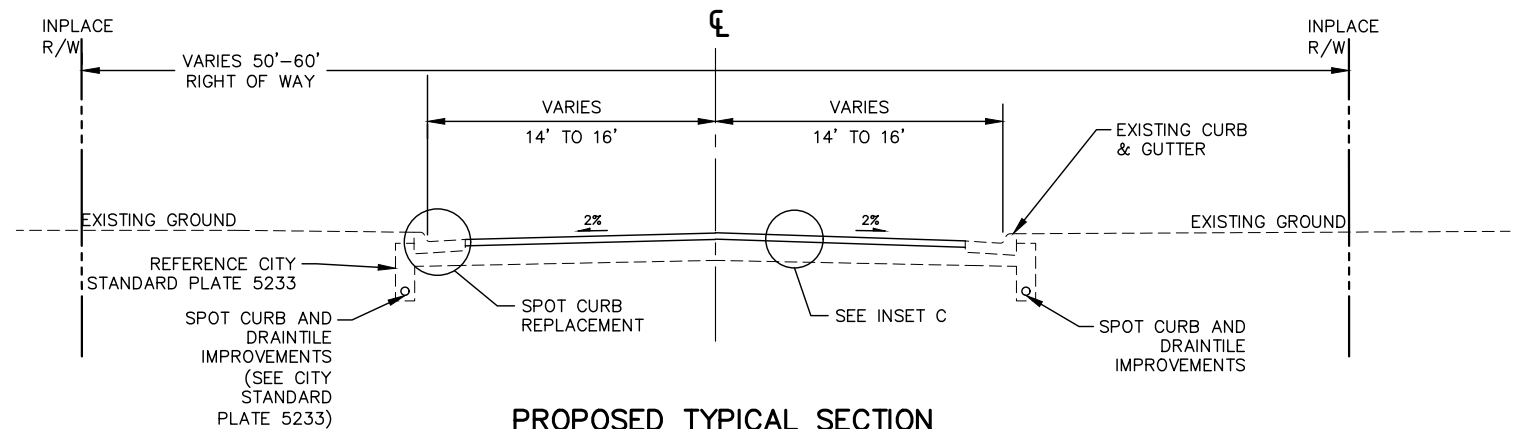

PROPOSED TYPICAL SECTION
MILL & OVERLAY
(SANTA FE, DEL RIO)

K:\TOW_Civil\City\CHANHASSEN\2024\CITY STREET REHAB-RECONSTRUCT\CAD\Plan Sheets\2024-PaveRehab-TYP.dwg February 29, 2024 - 6:54pm

No.	Date	Revisions	App.	DRAWING NAME
				2024-PaveRehab-TYP.dwg
				DESIGNED BY: MAK
				DRAWN BY: RCH
				CHECKED BY: MAK
				DATE: 02/29/2024
				PROJECT NO. 24-01

Kimley»Horn

11995 SINGLETREE LANE, SUITE 225, EDEN PRAIRIE, MN 55344
PHONE: 612-315-1272
WWW.KIMLEY-HORN.COM

I HEREBY CERTIFY THAT THIS PLAN, SPECIFICATION OR REPORT WAS PREPARED BY ME OR UNDER MY DIRECT SUPERVISION AND THAT I AM A DULY LICENSED PROFESSIONAL ENGINEER UNDER THE LAWS OF THE STATE OF MINNESOTA.

Michael A. Kirsch
MICHAEL A. KIRSCH
DATE: 02/29/2024 MN LIC. NO. 59057



CITY OF CHANHASSEN
2024 CITY PAVEMENT
REHABILITATION PROJECT

TYPICAL SECTIONS

CITY PROJECT	24-01	SHEET NO.
		30
		188

K:\TOW_Civil\CITY CHANHASSEN\2024 CITY STREET REHAB-RECONSTRUCT\CAD\Plan Sheets\2024_PaveRehab_ALIGN.dwg February 29, 2024 - 6:54pm

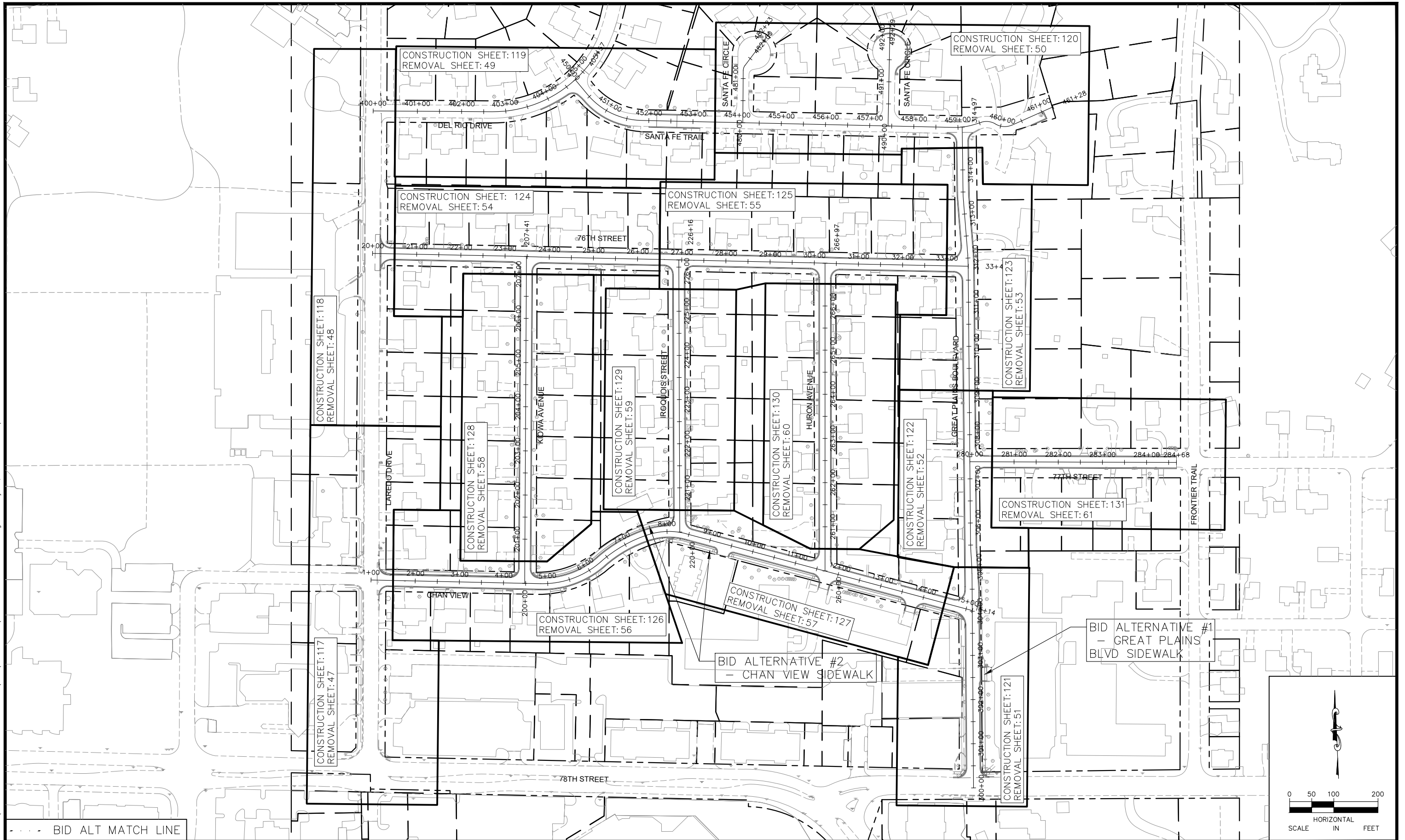

BID ALT MATCH LINE

No.	Date	Revisions	App.	DRAWING NAME
				2024_PaveRehab_ALIGN.dwg
				DESIGNED BY: MAK
				DRAWN BY: RCH
				CHECKED BY: MAK
				DATE: 02/29/2024
				PROJECT NO. 24-01

Kimley»Horn

11995 SINGLETREE LANE, SUITE 225, EDEN PRAIRIE, MN 55344
PHONE: 612-315-1272
WWW.KIMLEY-HORN.COM

I HEREBY CERTIFY THAT THIS PLAN, SPECIFICATION OR REPORT WAS PREPARED BY ME OR UNDER MY DIRECT SUPERVISION AND THAT I AM A DULY LICENSED PROFESSIONAL ENGINEER UNDER THE LAWS OF THE STATE OF MINNESOTA.

Michael A. Kirsch
MICHAEL A. KIRSCH

DATE: 02/29/2024 MN LIC. NO. 59057



CITY OF CHANHASSEN
2024 CITY PAVEMENT
REHABILITATION PROJECT

GENERAL LAYOUTS & BID ALT SPLITS
CHAN VIEW AREA

CITY PROJECT

24-01 SHEET NO.

32

188

**ALIGNMENT DATA
DEL-RIO-DR-ALGN**

SEGMENT NUMBER	BEGINNING STATION	ENDING STATION	PI STATION	NOTES	DELTA	DEGREE	RADIUS (FT)	TANGENT (FT)	LENGTH (FT)	BEGINNING COORDINATES NORTHING	BEGINNING COORDINATES EASTING	ENDING COORDINATES NORTHING	ENDING COORDINATES EASTING	AZIMUTH
L 400	400+00.00	402+69.32							269.32	182699.38	559733.72	182697.54	560003.03	90°23'23"
C 400	402+69.32	405+57.35	404+28.19		60°07'12"	20°52'22.01"	274.50	158.87	288.03	182697.54	560003.03	182833.67	560241.97	90°23'23" 30'16'11"

GENERAL NOTES

- CARVER COUNTY COORDINATE SYSTEM
- BASIS OF ELEVATION: NAD 83
- BENCHMARKS:
DESCRIPTION: CP EFN ADJ 5/8 REBAR
N: 182725.3522
E: 559702.7573
ELEV.: 990.9022'

**ALIGNMENT DATA
SANTA-FE-TRL-ALGN**

SEGMENT NUMBER	BEGINNING STATION	ENDING STATION	PI STATION	NOTES	DELTA	DEGREE	RADIUS (FT)	TANGENT (FT)	LENGTH (FT)	BEGINNING COORDINATES NORTHING	BEGINNING COORDINATES EASTING	ENDING COORDINATES NORTHING	ENDING COORDINATES EASTING	AZIMUTH
L 450	450+00.00	450+42.70							42.70	182770.20	560190.93	182737.26	560218.11	140°28'30"
C 450	450+42.70	451+83.05	451+17.53		49°10'53"	35°02'35.84"	163.50	74.82	140.34	182737.26	560218.11	182677.86	560340.53	140°28'30" 91°17'38"
L 451	451+83.05	458+89.49							706.44	182677.86	560340.53	182661.91	561046.79	91°17'38"
C 451	458+89.49	459+38.62	459+14.28		18°46'11"	38°11'49.87"	150.00	24.79	49.14	182661.91	561046.79	182668.79	561095.22	91°17'38" 72°31'27"
L 452	459+38.62	459+53.92							15.30	182668.79	561095.22	182673.39	561109.82	72°31'27"
C 452	459+53.92	459+86.15	459+70.97		46°09'29"	143°14'22.02"	40.00	17.04	32.22	182673.39	561109.82	182670.33	561141.03	72°31'27" 118°40'56"
L 453	459+86.15	459+89.59							3.45	182670.33	561141.03	182668.67	561144.05	118°40'56"
C 453	459+89.59	460+26.32	460+09.37		52°36'40"	143°14'22.02"	40.00	19.77	36.73	182668.67	561144.05	182667.20	561179.47	118°40'56" 66°04'15"
L 454	460+26.32	461+27.98							101.65	182667.20	561179.47	182708.43	561272.39	66°04'15"

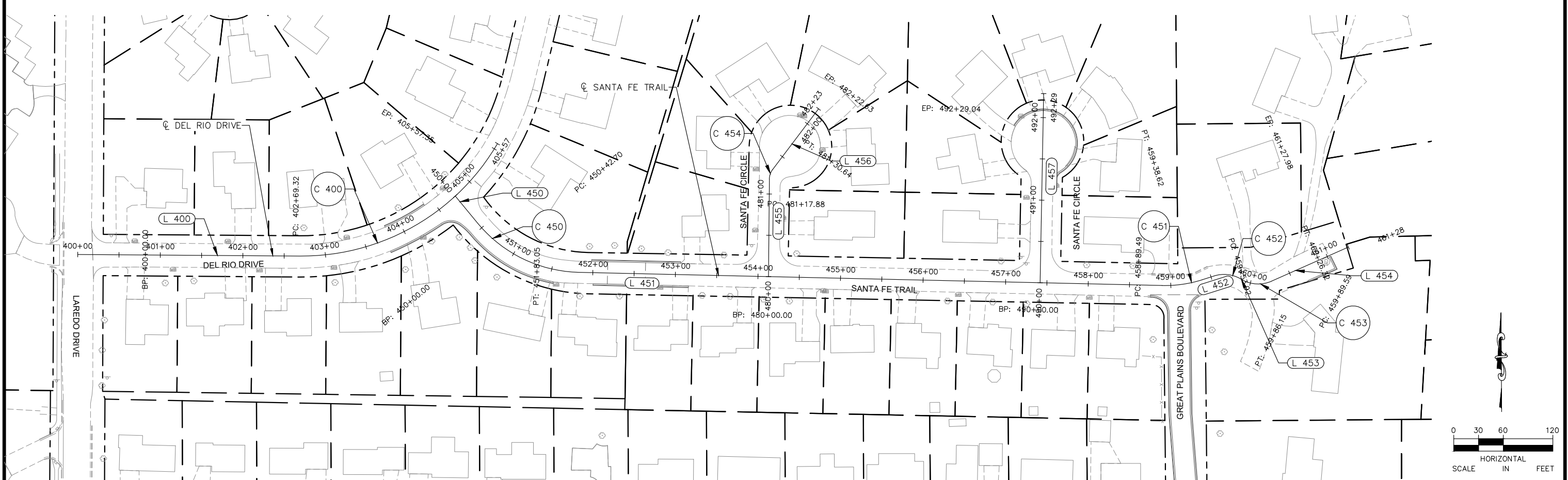

K:\TOW_Civil\City\CHANHASSEN\2024\CITY STREET REHAB-RECONSTRUCT\CAD\Plan Sheets\2024_PaveRehab_ALIGN.dwg February 29, 2024 - 6:54pm

No.	Date	Revisions	App.	DRAWING NAME		I HEREBY CERTIFY THAT THIS PLAN, SPECIFICATION OR REPORT WAS PREPARED BY ME OR UNDER MY DIRECT SUPERVISION AND THAT I AM A DULY LICENSED PROFESSIONAL ENGINEER UNDER THE LAWS OF THE STATE OF MINNESOTA. MICHAEL A. KIRSCH DATE: 02/29/2024 MN LIC. NO. 59057		CITY OF CHANHASSEN 2024 CITY PAVEMENT REHABILITATION PROJECT	CITY PROJECT 24-01	SHEET NO. 33

GENERAL NOTES

1. CARVER COUNTY COORDINATE SYSTEM
2. BASIS OF ELEVATION: NAD 83
3. BENCHMARKS:
DESCRIPTION: CP EFN ADJ 5/8 REBAR
N: 182725.3522
E: 559702.7573
ELEV.: 990.9022'

**ALIGNMENT DATA
SANTA-FE-CIR-01-ALGN**

SEGMENT NUMBER	BEGINNING STATION	ENDING STATION	PI STATION	NOTES	DELTA	DEGREE	RADIUS (FT)	TANGENT (FT)	LENGTH (FT)	BEGINNING COORDINATES NORTHING	BEGINNING COORDINATES EASTING	ENDING COORDINATES NORTHING	ENDING COORDINATES EASTING	AZIMUTH
L 455	480+00.00	481+17.88							117.88	182672.67	560570.21	182790.54	560571.27	0°30'54"
C 454	481+17.88	481+30.64	481+24.48		36°34'03"	286°28'44.03"	20.00	6.61	12.76	182790.54	560571.27	182802.42	560575.31	0°30'54" 37°04'57"
L 456	481+30.64	482+22.63							91.99	182802.42	560575.31	182875.81	560630.78	37°04'57"

**ALIGNMENT DATA
SANTA-FE-CIR-02-ALGN**

SEGMENT NUMBER	BEGINNING STATION	ENDING STATION	PI STATION	NOTES	DELTA	DEGREE	RADIUS (FT)	TANGENT (FT)	LENGTH (FT)	BEGINNING COORDINATES NORTHING	BEGINNING COORDINATES EASTING	ENDING COORDINATES NORTHING	ENDING COORDINATES EASTING	AZIMUTH
L 457	490+00.00	492+29.04							229.04	182665.24	560899.06	182894.24	560903.43	1°05'35"

K:\TOW_Civil\City\CHANHASSEN\2024_CITY STREET REHAB-RECONSTRUCT\CAD\Plan Sheets\2024_PaveRehab_ALIGN.dwg February 29, 2024 - 6:55pm

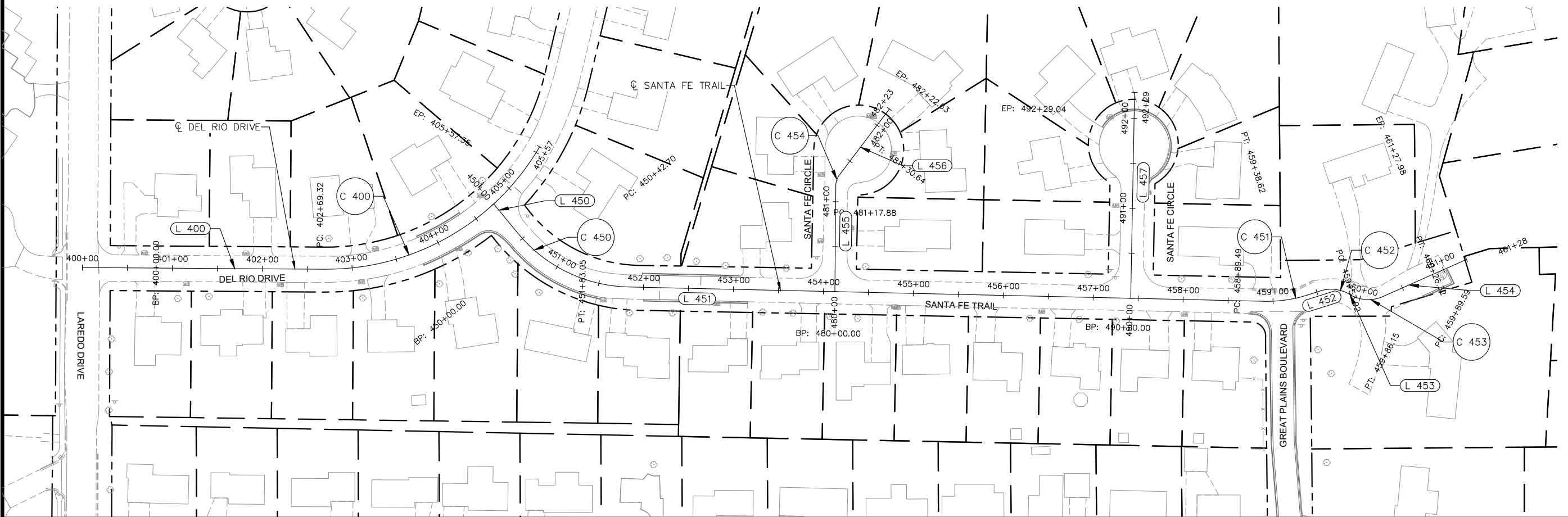

No.	Date	Revisions	App.	DRAWING NAME
				2024_PaveRehab_ALIGN.dwg
				DESIGNED BY: MAK
				DRAWN BY: RCH
				CHECKED BY: MAK
				DATE: 02/29/2024
				PROJECT NO. 24-01



11995 SINGLETREE LANE, SUITE 225, EDEN PRAIRIE, MN 55344
PHONE: 612-315-1272
WWW.KIMLEY-HORN.COM

I HEREBY CERTIFY THAT THIS PLAN, SPECIFICATION OR REPORT WAS PREPARED BY ME OR UNDER MY DIRECT SUPERVISION AND THAT I AM A DULY LICENSED PROFESSIONAL ENGINEER UNDER THE LAWS OF THE STATE OF MINNESOTA.

Michael A. Kirsch
MICHAEL A. KIRSCH
DATE: 02/29/2024 MN LIC. NO. 59057



CITY OF CHANHASSEN
2024 CITY PAVEMENT
REHABILITATION PROJECT

ALIGNMENT PLAN
SANTA FE CIRCLES
STA. 400+00 TO STA. 461+28

CITY PROJECT	24-01	SHEET NO.
		34
		188

GENERAL NOTES

1. CARVER COUNTY COORDINATE SYSTEM
2. BASIS OF ELEVATION: NAD 83
3. BENCHMARKS:

DESCRIPTION: CP EFN ADJ 5/8 REBAR
 N: 182725.3522
 E: 559702.7573
 ELEV.: 990.9022'

**ALIGNMENT DATA
 GREAT-PLAINS-BLVD-ALGN**

SEGMENT NUMBER	BEGINNING STATION	ENDING STATION	PI STATION	NOTES	DELTA	DEGREE	RADIUS (FT)	TANGENT (FT)	LENGTH (FT)	BEGINNING COORDINATES NORTHING	BEGINNING COORDINATES EASTING	ENDING COORDINATES NORTHING	ENDING COORDINATES EASTING	AZIMUTH
L 301	300+00.00	304+85.86							485.86	181166.27	561092.58	181652.12	561089.09	359°35'18"
C 301	304+85.86	305+02.51	304+94.19		3°10'51"	19°05'54.94"	300.00	8.33	16.66	181652.12	561089.09	181668.76	561088.51	359°35'18" 356°24'27"
L 302	305+02.51	305+36.81							34.30	181668.76	561088.51	181703.00	561086.36	356°24'27"
C 302	305+36.81	305+53.08	305+44.95		3°06'22"	19°05'54.94"	300.00	8.13	16.26	181703.00	561086.36	181719.25	561085.78	356°24'27" 359°30'49"
L 304	305+53.08	311+84.91							631.83	181719.25	561085.78	182351.05	561080.41	359°30'49"
C 303	311+84.91	312+06.09	311+95.51		4°02'47"	19°05'54.94"	300.00	10.60	21.19	182351.05	561080.41	182372.22	561079.49	359°30'49" 355°28'02"
L 305	312+06.09	313+30.38							124.29	182372.22	561079.49	182496.11	561069.66	355°28'02"
C 300	313+30.38	313+50.15	313+40.27		3°46'33"	19°05'54.94"	300.00	9.89	19.77	182496.11	561069.66	182515.86	561068.75	355°28'02" 359°14'35"
L 303	313+50.15	314+97.10							146.95	182515.86	561068.75	182662.79	561066.81	359°14'35"

K:\TOW_Civil\Civil\CHANHASSEN\2024 CITY STREET REHAB-RECONSTRUCT\CAD\Plan Sheets\2024_PaveRehab_ALIGN.dwg February 29, 2024 - 6:55pm

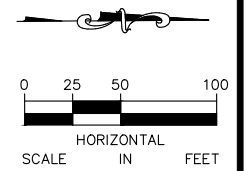
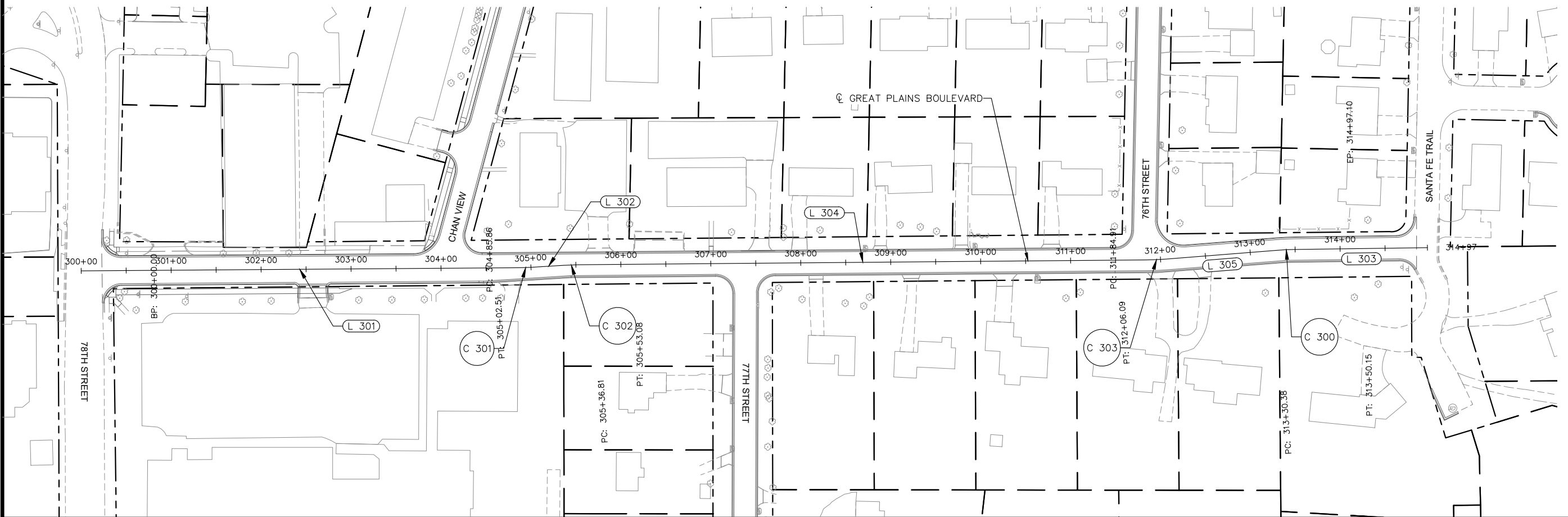

No.	Date	Revisions	App.

DRAWING NAME	2024_PaveRehab_ALIGN.dwg
DESIGNED BY:	MAK
DRAWN BY:	RCH
CHECKED BY:	MAK
DATE:	02/29/2024
PROJECT NO.	24-01

Kimley»Horn
 11995 SINGLETREE LANE, SUITE 225, EDEN PRAIRIE, MN 55344
 PHONE: 612-315-1272
 WWW.KIMLEY-HORN.COM

I HEREBY CERTIFY THAT THIS PLAN, SPECIFICATION OR REPORT WAS PREPARED BY ME OR UNDER MY DIRECT SUPERVISION AND THAT I AM A DULY LICENSED PROFESSIONAL ENGINEER UNDER THE LAWS OF THE STATE OF MINNESOTA.

Michael A. Kirsch
 MICHAEL A. KIRSCH
 DATE: 02/29/2024 MN LIC. NO. 59057



CITY OF CHANHASSEN
 2024 CITY PAVEMENT
 REHABILITATION PROJECT

ALIGNMENT PLAN
 GREAT PLAINS BOULEVARD
 STA. 300+00 TO STA. 314+97

CITY PROJECT	24-01	SHEET NO.	35
			188

GENERAL NOTES

1. CARVER COUNTY COORDINATE SYSTEM
2. BASIS OF ELEVATION: NAD 83
3. BENCHMARKS:
DESCRIPTION: CP EFN ADJ 5/8 REBAR
N: 182725.3522
E: 559702.7573
ELEV.: 990.9022'

**ALIGNMENT DATA
76TH-ST-ALGN**

SEGMENT NUMBER	BEGINNING STATION	ENDING STATION	PI STATION	NOTES	DELTA	DEGREE	RADIUS (FT)	TANGENT (FT)	LENGTH (FT)	BEGINNING COORDINATES NORTHING	BEGINNING COORDINATES EASTING	ENDING COORDINATES NORTHING	ENDING COORDINATES EASTING	AZIMUTH
L 200	20+00.00	23+14.56							314.56	182376.70	559732.22	182370.48	560046.72	91°07'58"
C 200	23+14.56	23+16.54	23+15.55		0°33'57"	28°38'52.40"	200.00	0.99	1.98	182370.48	560046.72	182370.43	560048.69	91°07'58" 91°41'55"
L 201	23+16.54	23+81.38							64.84	182370.43	560048.69	182368.51	560113.51	91°41'55"
C 201	23+81.38	23+83.16	23+82.27		0°30'31"	28°38'52.40"	200.00	0.89	1.78	182368.51	560113.51	182368.47	560115.28	91°41'55" 91°11'24"
L 202	23+83.16	26+60.37							277.21	182368.47	560115.28	182362.71	560392.43	91°11'24"
C 202	26+60.37	26+61.07	26+60.72		0°12'08"	28°38'52.40"	200.00	0.35	0.71	182362.71	560392.43	182362.69	560393.14	91°11'24" 91°23'32"
L 203	26+61.07	27+27.32							66.24	182362.69	560393.14	182361.08	560459.36	91°23'32"
C 203	27+27.32	27+27.94	27+27.63		0°10'44"	28°38'52.40"	200.00	0.31	0.62	182361.08	560459.36	182361.07	560459.99	91°23'32" 91°12'48"
L 204	27+27.94	29+90.62							262.68	182361.07	560459.99	182355.51	560722.61	91°12'48"
C 204	29+90.62	29+92.79	29+91.70		0°37'17"	28°38'52.40"	200.00	1.08	2.17	182355.51	560722.61	182355.45	560724.77	91°12'48" 91°50'05"
L 205	29+92.79	30+56.94							64.15	182355.45	560724.77	182353.39	560788.89	91°50'05"
C 205	30+56.94	30+59.34	30+58.14		0°41'18"	28°38'52.40"	200.00	1.20	2.40	182353.39	560788.89	182353.33	560791.29	91°50'05" 91°08'46"
L 206	30+59.34	33+48.55							289.21	182353.33	560791.29	182347.55	561080.44	91°08'46"

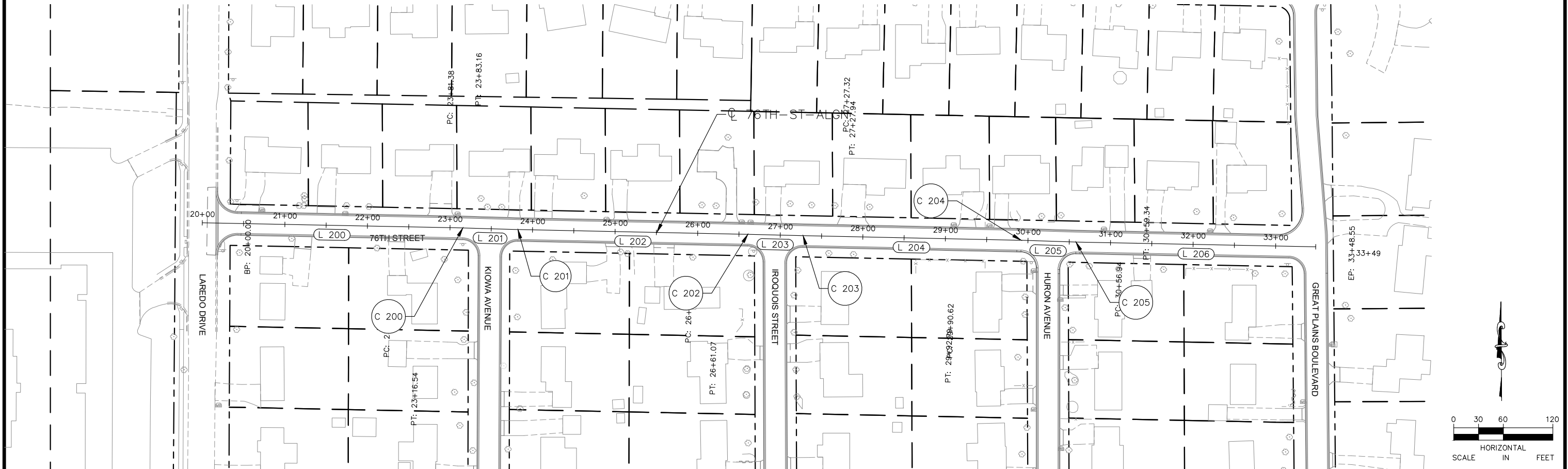

K:\TOW_Civil\City\CHANHASSEN\2024\CITY STREET REHAB-RECONSTRUCT\CAD\Plan Sheets\2024_PaveRehab_ALIGN.dwg February 29, 2024 - 6:55pm

No.	Date	Revisions	App.

DRAWING NAME 2024_PaveRehab_ALIGN.dwg	
DESIGNED BY:	MAK
DRAWN BY:	RCH
CHECKED BY:	MAK
DATE:	02/29/2024
PROJECT NO.	24-01

Kimley»Horn

11995 SINGLETREE LANE, SUITE 225, EDEN PRAIRIE, MN 55344
PHONE: 612-315-1272
WWW.KIMLEY-HORN.COM

I HEREBY CERTIFY THAT THIS PLAN, SPECIFICATION OR REPORT WAS PREPARED BY ME OR UNDER MY DIRECT SUPERVISION AND THAT I AM A DULY LICENSED PROFESSIONAL ENGINEER UNDER THE LAWS OF THE STATE OF MINNESOTA.

Michael A. Kirsch
MICHAEL A. KIRSCH
DATE: 02/29/2024 MN LIC. NO. 59057



CITY OF CHANHASSEN
2024 CITY PAVEMENT
REHABILITATION PROJECT

ALIGNMENT PLAN
76TH STREET
STA. 20+00 TO STA. 33+46

CITY PROJECT	24-01	SHEET NO.	36
			188

GENERAL NOTES

1. CARVER COUNTY COORDINATE SYSTEM
2. BASIS OF ELEVATION: NAD 83
3. BENCHMARKS:
DESCRIPTION: CP EFN ADJ 5/8 REBAR
N: 182725.3522
E: 559702.7573
ELEV.: 990.9022'

ALIGNMENT DATA KIOWA-ALGN														
SEGMENT NUMBER	BEGINNING STATION	ENDING STATION	PI STATION	NOTES	DELTA	DEGREE	RADIUS (FT)	TANGENT (FT)	LENGTH (FT)	BEGINNING COORDINATES NORTHING	BEGINNING COORDINATES EASTING	ENDING COORDINATES NORTHING	ENDING COORDINATES EASTING	AZIMUTH
L 600	200+00.00	207+40.50							740.50	181629.50	560076.61	182369.99	560080.61	0°18'34"

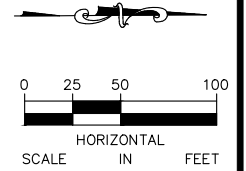

K:\TOW_Civil\Civil\CHANHASSEN\2024 CITY STREET REHAB-RECONSTRUCT\CAD\Plan Sheets\2024_PaveRehab_ALIGN.dwg February 23, 2024 - 6:55pm

No.	Date	Revisions	App.	DRAWING NAME
				2024_PaveRehab_ALIGN.dwg
				DESIGNED BY: MAK
				DRAWN BY: RCH
				CHECKED BY: MAK
				DATE: 02/29/2024
				PROJECT NO. 24-01

Kimley»Horn
 11995 SINGLETREE LANE, SUITE 225, EDEN PRAIRIE, MN 55344
 PHONE: 612-315-1272
 WWW.KIMLEY-HORN.COM

I HEREBY CERTIFY THAT THIS PLAN, SPECIFICATION OR REPORT WAS PREPARED BY ME OR UNDER MY DIRECT SUPERVISION AND THAT I AM A DULY LICENSED PROFESSIONAL ENGINEER UNDER THE LAWS OF THE STATE OF MINNESOTA.
Michael A. Kirsch
 MICHAEL A. KIRSCH
 DATE: 02/29/2024 MN LIC. NO. 59057



CITY OF CHANHASSEN
 2024 CITY PAVEMENT
 REHABILITATION PROJECT
 ALIGNMENT PLAN
 KIOWA AVENUE
 STA. 200+00 TO STA. 207+40

CITY PROJECT	24-01	SHEET NO.
		37
		188

GENERAL NOTES

1. CARVER COUNTY COORDINATE SYSTEM
2. BASIS OF ELEVATION: NAD 83
3. BENCHMARKS:
DESCRIPTION: CP EFN ADJ 5/8 REBAR
N: 182725.3522
E: 559702.7573
ELEV.: 990.9022'

**ALIGNMENT DATA
IROQUOIS-ALGN**

SEGMENT NUMBER	BEGINNING STATION	ENDING STATION	PI STATION	NOTES	DELTA	DEGREE	RADIUS (FT)	TANGENT (FT)	LENGTH (FT)	BEGINNING COORDINATES NORTHING	BEGINNING COORDINATES EASTING	ENDING COORDINATES NORTHING	ENDING COORDINATES EASTING	AZIMUTH
L 700	220+00.00	226+16.23							616.23	181745.68	560427.60	182361.91	560425.32	359°47'20"

K:\TOW_Civil\City\CHANHASSEN\2024_CITY STREET REHAB-RECONSTRUCT\CAD\Plan Sheets\2024_PaveRehab_ALIGN.dwg February 29, 2024 - 6:55pm

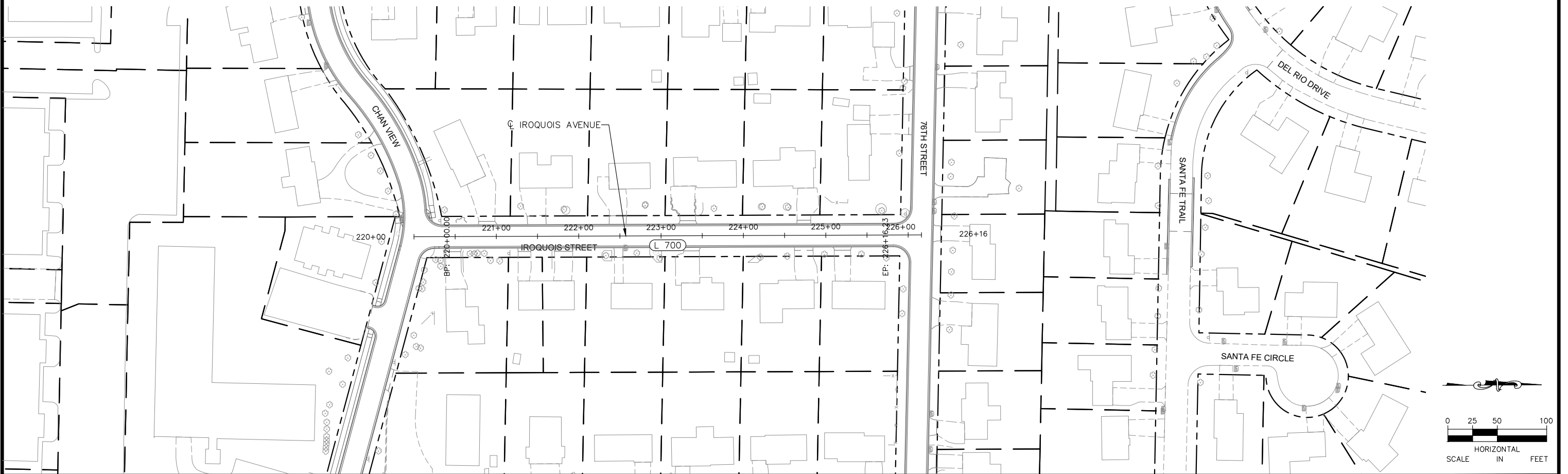

No.	Date	Revisions	App.	DRAWING NAME
				2024_PaveRehab_ALIGN.dwg
				DESIGNED BY: MAK
				DRAWN BY: RCH
				CHECKED BY: MAK
				DATE: 02/29/2024
				PROJECT NO. 24-01

Kimley»Horn

11995 SINGLETREE LANE, SUITE 225, EDEN PRAIRIE, MN 55344
PHONE: 612-315-1272
WWW.KIMLEY-HORN.COM

I HEREBY CERTIFY THAT THIS PLAN, SPECIFICATION OR REPORT WAS PREPARED BY ME OR UNDER MY DIRECT SUPERVISION AND THAT I AM A DULY LICENSED PROFESSIONAL ENGINEER UNDER THE LAWS OF THE STATE OF MINNESOTA.

Michael A. Kirsch
MICHAEL A. KIRSCH
DATE: 02/29/2024 MN LIC. NO. 59057



CITY OF CHANHASSEN
2024 CITY PAVEMENT
REHABILITATION PROJECT

ALIGNMENT PLAN
IROQUOIS STREET
STA. 220+00 TO STA. 226+16

CITY PROJECT	24-01	SHEET NO.
		38
		188

GENERAL NOTES

1. CARVER COUNTY COORDINATE SYSTEM
2. BASIS OF ELEVATION: NAD 83
3. BENCHMARKS:
DESCRIPTION: CP EFN ADJ 5/8 REBAR
N: 182725.3522
E: 559702.7573
ELEV.: 990.9022'

**ALIGNMENT DATA
HURON-ALGN**

SEGMENT NUMBER	BEGINNING STATION	ENDING STATION	PI STATION	NOTES	DELTA	DEGREE	RADIUS (FT)	TANGENT (FT)	LENGTH (FT)	BEGINNING COORDINATES NORTHING	BEGINNING COORDINATES EASTING	ENDING COORDINATES NORTHING	ENDING COORDINATES EASTING	AZIMUTH
L 800	260+00.00	266+96.83							696.83	181657.61	560756.39	182354.44	560756.38	359°59'55"

K:\TOW_Civil\City\CHANHASSEN\2024 CITY STREET REHAB-RECONSTRUCT\CAD\Plan Sheets\2024_PaveRehab_ALIGN.dwg February 29, 2024 - 6:55pm

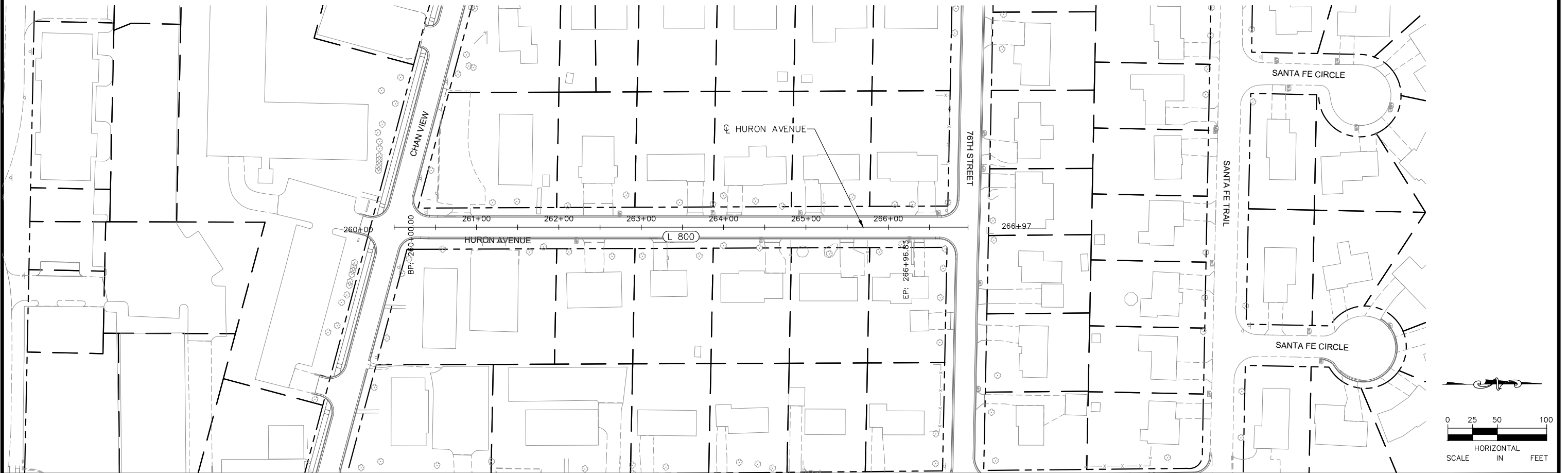

No.	Date	Revisions	App.	DRAWING NAME
				2024_PaveRehab_ALIGN.dwg
				DESIGNED BY: MAK
				DRAWN BY: RCH
				CHECKED BY: MAK
				DATE: 02/29/2024
				PROJECT NO. 24-01

Kimley»Horn

11995 SINGLETREE LANE, SUITE 225, EDEN PRAIRIE, MN 55344
PHONE: 612-315-1272
WWW.KIMLEY-HORN.COM

I HEREBY CERTIFY THAT THIS PLAN, SPECIFICATION OR REPORT WAS PREPARED BY ME OR UNDER MY DIRECT SUPERVISION AND THAT I AM A DULY LICENSED PROFESSIONAL ENGINEER UNDER THE LAWS OF THE STATE OF MINNESOTA.

Michael A. Kirsch
MICHAEL A. KIRSCH
DATE: 02/29/2024 MN LIC. NO. 59057



CITY OF CHANHASSEN
2024 CITY PAVEMENT
REHABILITATION PROJECT

ALIGNMENT PLAN
HURON AVENUE
STA. 260+00 TO STA. 266+97

CITY PROJECT	24-01	SHEET NO.
		39
		188

GENERAL NOTES

1. CARVER COUNTY COORDINATE SYSTEM
 2. BASIS OF ELEVATION: NAD 83
 3. BENCHMARKS:
- DESCRIPTION: CP EFN ADJ 5/8 REBAR
 N: 182725.3522
 E: 559702.7573
 ELEV.: 990.9022'

ALIGNMENT DATA CHAN-VIEW-ALIGN														
SEGMENT NUMBER	BEGINNING STATION	ENDING STATION	PI STATION	NOTES	DELTA	DEGREE	RADIUS (FT)	TANGENT (FT)	LENGTH (FT)	BEGINNING COORDINATES NORTHING	BEGINNING COORDINATES EASTING	ENDING COORDINATES NORTHING	ENDING COORDINATES EASTING	AZIMUTH
L 100	1+00.00	4+84.17							384.17	181636.99	559728.78	181628.71	560112.86	91°14'06"
C 100	4+84.17	6+33.11	5+62.28		42°40'04"	28°38'52.40"	200.00	78.11	148.94	181628.71	560112.86	181678.72	560249.52	91°14'06" 48°34'02"
C 101	6+33.11	7+58.80	6+96.89		24°00'21"	19°05'54.94"	300.00	63.78	125.69	181678.72	560249.52	181740.03	560358.19	48°34'02" 72°34'22"
C 102	7+58.80	8+43.77	8+02.46		32°27'14"	38°11'49.87"	150.00	43.66	84.96	181740.03	560358.19	181741.79	560442.01	72°34'22" 105°01'37"
L 101	8+43.77	15+14.38							670.62	181741.79	560442.01	181567.91	561089.69	105°01'37"

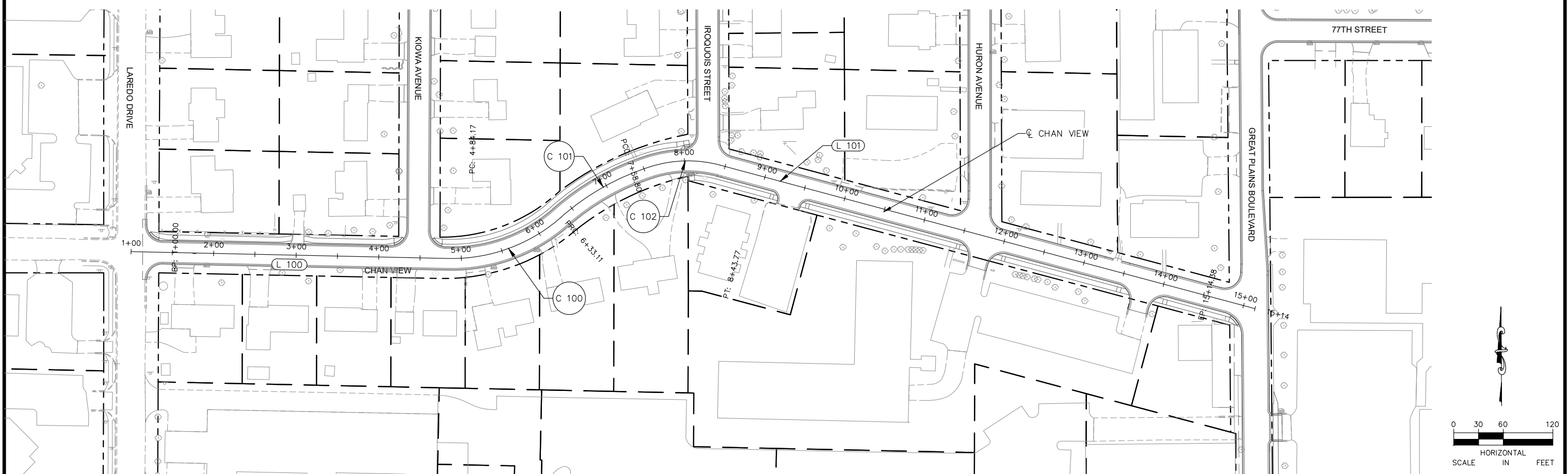

K:\TOW_Civil\Civil\CHANHASSEN\2024_CITY STREET REHAB-RECONSTRUCT\CAD\Plan Sheets\2024_PaveRehab_ALIGN.dwg February 29, 2024 - 6:55pm

No.	Date	Revisions	App.	DRAWING NAME
				2024_PaveRehab_ALIGN.dwg
				DESIGNED BY: MAK
				DRAWN BY: RCH
				CHECKED BY: MAK
				DATE: 02/29/2024
				PROJECT NO. 24-01

Kimley»Horn
 11995 SINGLETREE LANE, SUITE 225, EDEN PRAIRIE, MN 55344
 PHONE: 612-315-1272
 WWW.KIMLEY-HORN.COM

I HEREBY CERTIFY THAT THIS PLAN, SPECIFICATION OR REPORT WAS PREPARED BY ME OR UNDER MY DIRECT SUPERVISION AND THAT I AM A DULY LICENSED PROFESSIONAL ENGINEER UNDER THE LAWS OF THE STATE OF MINNESOTA.

Michael A. Kirsch
 MICHAEL A. KIRSCH
 DATE: 02/29/2024 MN LIC. NO. 59057



CITY OF CHANHASSEN
 2024 CITY PAVEMENT
 REHABILITATION PROJECT

ALIGNMENT PLAN
 CHAN VIEW
 STA. 1+00 TO STA. 15+14

CITY PROJECT	24-01	SHEET NO.
		40
		188

GENERAL NOTES

1. CARVER COUNTY COORDINATE SYSTEM
2. BASIS OF ELEVATION: NAD 83
3. BENCHMARKS:
DESCRIPTION: CP EFN ADJ 5/8 REBAR
N: 182725.3522
E: 559702.7573
ELEV.: 990.9022'

**ALIGNMENT DATA
77TH-ST-ALGN**

SEGMENT NUMBER	BEGINNING STATION	ENDING STATION	PI STATION	NOTES	DELTA	DEGREE	RADIUS (FT)	TANGENT (FT)	LENGTH (FT)	BEGINNING COORDINATES NORTHING	BEGINNING COORDINATES EASTING	ENDING COORDINATES NORTHING	ENDING COORDINATES EASTING	AZIMUTH
L 900	280+00.00	284+67.63							467.63	181904.97	561084.20	181903.19	561551.83	90°13'08"

K:\TOW_Civil\City\CHANHASSEN\2024 CITY STREET REHAB-RECONSTRUCT\CAD\Plan Sheets\2024_PaveRehab_ALIGN.dwg February 29, 2024 - 6:55pm

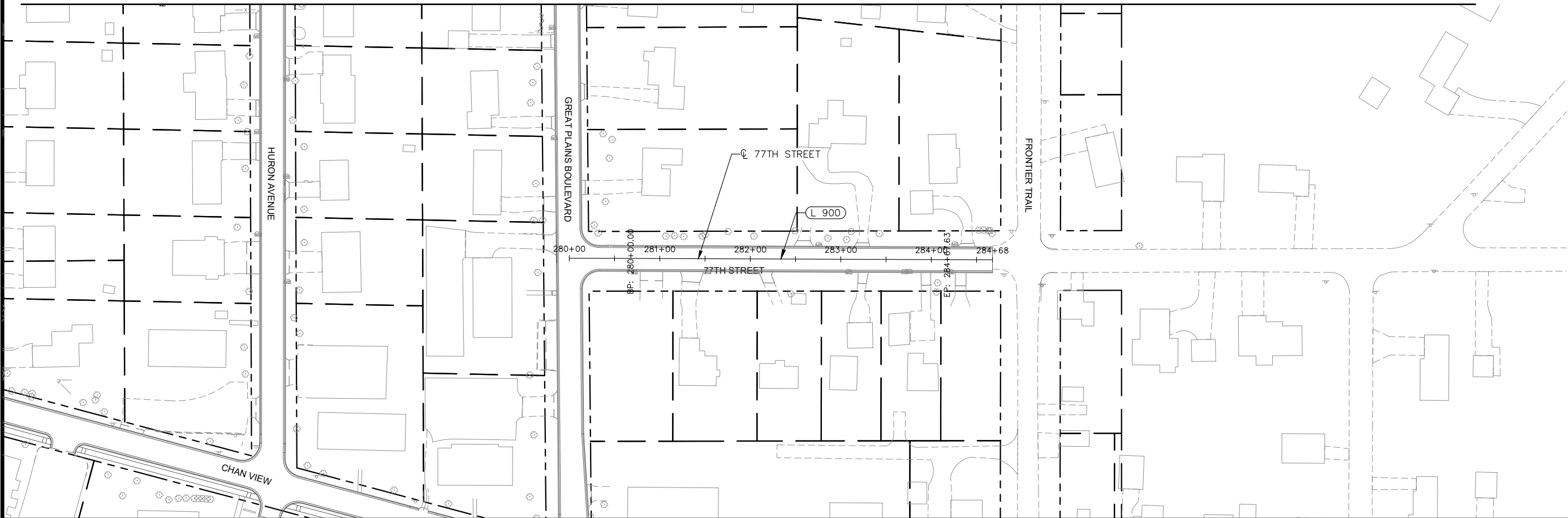

No.	Date	Revisions	App.	DRAWING NAME
				2024_PaveRehab_ALIGN.dwg
				DESIGNED BY: MAK
				DRAWN BY: RCH
				CHECKED BY: MAK
				DATE: 02/29/2024
				PROJECT NO. 24-01



11995 SINGLETREE LANE, SUITE 225, EDEN PRAIRIE, MN 55344
PHONE: 612-315-1272
WWW.KIMLEY-HORN.COM

I HEREBY CERTIFY THAT THIS PLAN, SPECIFICATION OR REPORT WAS PREPARED BY ME OR UNDER MY DIRECT SUPERVISION AND THAT I AM A DULY LICENSED PROFESSIONAL ENGINEER UNDER THE LAWS OF THE STATE OF MINNESOTA.

Michael A. Kirsch
MICHAEL A. KIRSCH
DATE: 02/29/2024 MN LIC. NO. 59057



CITY OF CHANHASSEN
2024 CITY PAVEMENT
REHABILITATION PROJECT

ALIGNMENT PLAN
77TH STREET
STA. 280+00 TO STA. 284+68

CITY PROJECT 24-01

SHEET NO.

41

188

**ALIGNMENT DATA
STONE-CREEK-ALGN**

SEGMENT NUMBER	BEGINNING STATION	ENDING STATION	PI STATION	NOTES	DELTA	DEGREE	RADIUS (FT)	TANGENT (FT)	LENGTH (FT)	BEGINNING COORDINATES NORTHING	BEGINNING COORDINATES EASTING	ENDING COORDINATES NORTHING	ENDING COORDINATES EASTING	AZIMUTH
L 1000	500+00.00	500+27.18							27.18	177278.55	550362.26	177277.70	550389.43	91°47'37"
C 1000	500+27.18	502+58.49	501+53.27		56°38'13"	24°29'07.35"	234.00	126.09	231.31	177277.70	550389.43	177376.84	550588.07	91°47'37" 35°09'24"
L 1001	502+58.49	507+40.19							481.70	177376.84	550588.07	177770.67	550865.44	35°09'24"
C 1001	507+40.19	512+13.45	510+20.96		77°28'25"	16°22'12.80"	350.00	280.77	473.26	177770.67	550865.44	178207.84	550838.08	35°09'24" 317°40'59"
L 1002	512+13.45	512+75.82							62.38	178207.84	550838.08	178253.96	550796.09	317°40'59"
C 1002	512+75.82	514+76.67	513+81.56		44°15'40"	22°02'12.62"	260.00	105.74	200.85	178253.96	550796.09	178437.82	550728.49	317°40'59" 1°56'38"
L 1003	514+76.67	516+44.05							167.38	178437.82	550728.49	178605.10	550734.17	1°56'38"
C 1003	516+44.05	518+86.85	517+68.55		31°15'41"	12°52'31.64"	445.00	124.50	242.80	178605.10	550734.17	178833.70	550806.58	1°56'38" 33°12'19"
L 1004	518+86.85	521+75.46							288.61	178833.70	550806.58	179075.19	550964.63	33°12'19"
C 1004	521+75.46	525+83.48	524+35.07		89°54'52"	22°02'12.62"	260.00	259.61	408.02	179075.19	550964.63	179434.91	550889.80	33°12'19" 303°17'27"
L 1005	525+83.48	526+79.58							96.11	179434.91	550889.80	179487.66	550809.46	303°17'27"
C 1005	526+79.58	529+37.79	528+11.35		28°10'45"	10°54'48.53"	525.00	131.77	258.21	179487.66	550809.46	179675.76	550636.38	303°17'27" 331°28'13"
C 1006	529+37.79	532+39.10	530+91.12		26°09'27"	8°40'52.24"	660.00	153.33	301.31	179675.76	550636.38	179967.22	550571.03	334°17'01" 0°26'28"
L 1006	532+39.10	534+22.10							183.00	179967.22	550571.03	180150.22	550572.44	0°26'28"
C 1007	534+22.10	535+20.25	534+71.46		14°59'46"	15°16'43.95"	375.00	49.36	98.15	180150.22	550572.44	180247.15	550585.96	0°26'28" 15°26'14"
L 1007	535+20.25	536+32.49							112.24	180247.15	550585.96	180355.34	550615.83	15°26'14"

GENERAL NOTES

- CARVER COUNTY COORDINATE SYSTEM
- BASIS OF ELEVATION: NAD 83
- BENCHMARKS:
DESCRIPTION: CP EFN ADJ 5/8 REBAR
N: 182725.3522
E: 559702.7573
ELEV.: 990.9022'

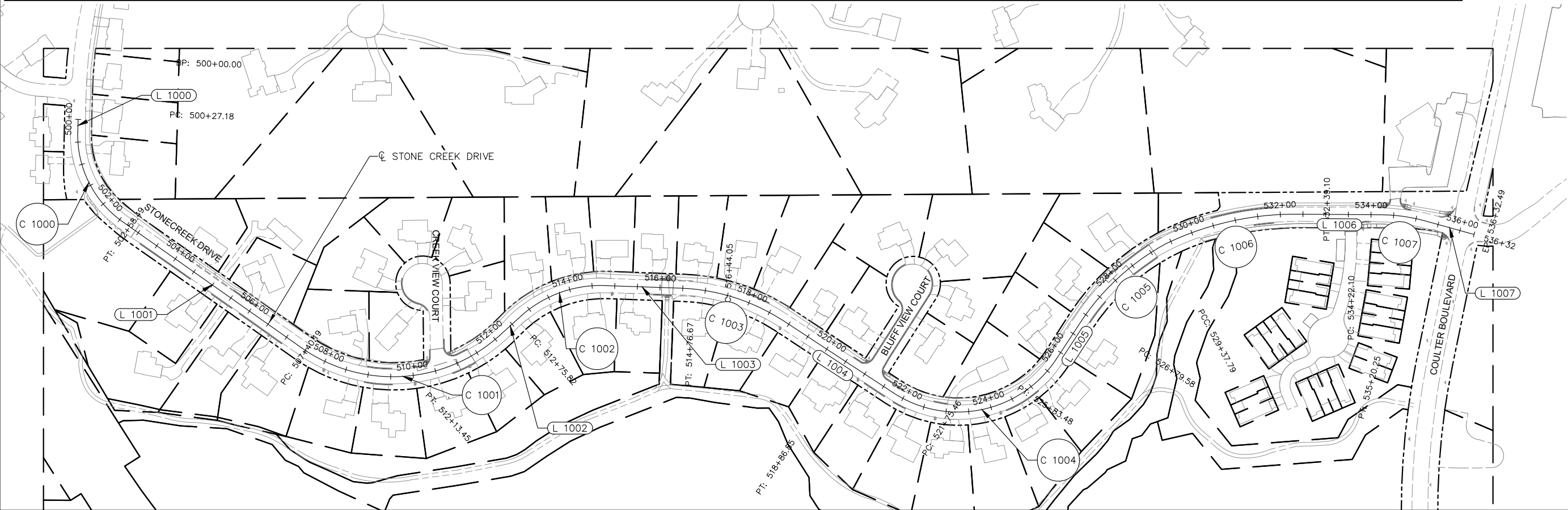

No.	Date	Revisions	App.

DRAWING NAME	
DESIGNED BY:	MAK
DRAWN BY:	RCH
CHECKED BY:	MAK
DATE:	02/29/2024
PROJECT NO.	24-01

Kimley»Horn

11995 SINGLETREE LANE, SUITE 225, EDEN PRAIRIE, MN 55344
PHONE: 612-315-1272
WWW.KIMLEY-HORN.COM

I HEREBY CERTIFY THAT THIS PLAN, SPECIFICATION OR REPORT WAS PREPARED BY ME OR UNDER MY DIRECT SUPERVISION AND THAT I AM A DULY LICENSED PROFESSIONAL ENGINEER UNDER THE LAWS OF THE STATE OF MINNESOTA.

Michael A. Kirsch
MICHAEL A. KIRSCH
DATE: 02/29/2024 MN LIC. NO. 59057

CITY OF CHANHASSEN
2024 CITY PAVEMENT
REHABILITATION PROJECT

ALIGNMENT PLAN
STONE CREEK DRIVE

CITY PROJECT	24-01	SHEET NO.
		42
		188

K:\TOW_Civil\City\CHANHASSEN\2024 CITY STREET REHAB-RECON\CAD\Plan Sheets\2024_PaveRehab_ALIGN.dwg February 29, 2024 - 6:55pm

GENERAL NOTES

1. CARVER COUNTY COORDINATE SYSTEM
2. BASIS OF ELEVATION: NAD 83
3. BENCHMARKS:
DESCRIPTION: CP EFN ADJ 5/8 REBAR
N: 182725.3522
E: 559702.7573
ELEV.: 990.9022'

**ALIGNMENT DATA
CREEK-VIEW-CT-ALGN**

SEGMENT NUMBER	BEGINNING STATION	ENDING STATION	PI STATION	NOTES	DELTA	DEGREE	RADIUS (FT)	TANGENT (FT)	LENGTH (FT)	BEGINNING COORDINATES NORTHING	BEGINNING COORDINATES EASTING	ENDING COORDINATES NORTHING	ENDING COORDINATES EASTING	AZIMUTH
L 1100	600+00.00	601+15.11							115.11	178069.35	550915.53	178067.62	550800.44	269°08'26"
C 1100	601+15.11	601+69.55	601+43.02		31°11'35"	57°17'44.81"	100.00	27.91	54.44	178067.62	550800.44	178052.39	550748.87	269°08'26" 237°56'51"
L 1101	601+69.55	602+62.75							93.20	178052.39	550748.87	178002.93	550669.88	237°56'51"

**ALIGNMENT DATA
BLUFF-VIEW-CT-ALGN**

SEGMENT NUMBER	BEGINNING STATION	ENDING STATION	PI STATION	NOTES	DELTA	DEGREE	RADIUS (FT)	TANGENT (FT)	LENGTH (FT)	BEGINNING COORDINATES NORTHING	BEGINNING COORDINATES EASTING	ENDING COORDINATES NORTHING	ENDING COORDINATES EASTING	AZIMUTH
L 1200	650+00.00	651+46.28							146.28	179021.66	550929.59	179100.57	550806.42	302°38'49"
C 1200	651+46.28	652+00.35	651+73.99		30°58'48"	57°17'44.81"	100.00	27.71	54.07	179100.57	550806.42	179116.32	550755.39	302°38'49" 271°40'01"
L 1201	652+00.35	652+91.57							91.23	179116.32	550755.39	179118.98	550664.20	271°40'01"



K:\TOW_Civil\Civil\CHANHASSEN\2024 CITY STREET REHAB-RECONSTRUCT\CAD\Plan Sheets\2024_PaveRehab_ALIGN.dwg February 29, 2024 - 6:55pm

No.	Date	Revisions	App.

DRAWING NAME
2024_PaveRehab_ALIGN.dwg
DESIGNED BY: MAK
DRAWN BY: RCH
CHECKED BY: MAK
DATE: 02/29/2024
PROJECT NO. 24-01

Kimley»Horn
11995 SINGLETREE LANE, SUITE 225, EDEN PRAIRIE, MN 55344
PHONE: 612-315-1272
WWW.KIMLEY-HORN.COM

I HEREBY CERTIFY THAT THIS PLAN, SPECIFICATION OR REPORT WAS PREPARED BY ME OR UNDER MY DIRECT SUPERVISION AND THAT I AM A DULY LICENSED PROFESSIONAL ENGINEER UNDER THE LAWS OF THE STATE OF MINNESOTA.
Michael A. Kirsch
MICHAEL A. KIRSCH
DATE: 02/29/2024 MN LIC. NO. 59057



CITY OF CHANHASSEN
2024 CITY PAVEMENT
REHABILITATION PROJECT
ALIGNMENT PLAN
CREEK VIEW AND BLUFF VIEW COURTS

CITY PROJECT	24-01	SHEET NO.
		43
		188

STORM WATER POLLUTION PREVENTION PLAN (SWPPP) NARRATIVE

PROJECT DESCRIPTION/LOCATION:

CHANHASSEN CITY PROJECT 24-01 IS LOCATED CHAN VIEW, LAREDO DRIVE, GREAT PLAINS BOULEVARD, SANTA FE TRAIL, KIOWA AVENUE, IROQUOIS STREET, HURON AVENUE, 76TH STREET, AND STONE CREEK DRIVE. .

THE PLANNED SCOPE OF THE PROJECT INCLUDES:

MILL AND OVERLAY, FULL DEPTH RECLAMATION, BITUMINOUS SURFACING, CONCRETE CURB AND GUTTER, ADA IMPROVEMENTS, STORM SEWER, STORM WATER MANAGEMENT FACILITIES, AND PUBLIC UTILITY IMPROVEMENTS.

THE TOTAL SITE AREA IS 14.51 ACRES, WHICH INCLUDES AN INCREASE OF 0.18 ACRES OF IMPERVIOUS AREA.

SPECIAL AND IMPAIRED WATERS:

THESE SPECIAL AND/OR IMPAIRED WATERS ARE LOCATED WITHIN ONE MILE OF THE PROJECT LIMITS AND RECEIVE RUNOFF FROM THE PROJECT SITE. DUE TO THE PROXIMITY OF THESE SPECIAL AND IMPAIRED WATERS THE BMPS DESCRIBED IN APPENDIX A OF THE NPDES PERMIT WILL APPLY TO ALL AREAS OF THE SITE.

WATERBODY	IMPAIRMENT(S)
LOTUS LAKE	FISH BIOASSESSMENTS, MERCURY IN FISH TISSUE, AND NUTRIENTS
RICE MARSH LAKE	NUTRIENTS
BLUFF CREEK	FISH BIOASSESSMENTS, TURBIDITY

ENVIRONMENTAL REVIEW:

AN ENVIRONMENTAL REVIEW WAS NOT COMPLETED FOR THIS PROJECT. THERE WERE NOT ANY COMMITMENTS AS A RESULT OF THE ENVIRONMENTAL REVIEW. THIS PROJECT IS NOT LOCATED IN A WELL HEAD PROTECTION OR DRINKING WATER SUPPLY MANAGEMENT AREA, AND IS NOT WITHIN AN EMERGENCY RESPONSE AREA (ERA). THERE ARE NO KNOWN OR PROPOSED DISCHARGES TO CALCAREOUS FENS ON THIS PROJECT.

SWPPP TRAINING:

THE PROJECT SWPPP WAS PREPARED BY PERSONNEL THAT ARE CERTIFIED IN THE DESIGN OF CONSTRUCTION SWPPP'S. COPIES OF CERTIFICATIONS ARE AVAILABLE UPON REQUEST.

CERTIFIED SWPPP PERSONNEL: ADAM TJADEN
TRAINING EXPIRES: 2024

THE CONTRACTOR IS RESPONSIBLE FOR PROVIDING A CERTIFIED EROSION CONTROL SUPERVISOR THAT IS RESPONSIBLE FOR OVERSEEING THE IMPLEMENTATION OF THE SWPPP. THE CONTRACTOR MUST PROVIDE PROOF OF CERTIFICATION AT THE PRECONSTRUCTION MEETING AND WILL NOT BE ALLOWED TO COMMENCE WORK UNTIL PROOF OF CERTIFICATION HAS BEEN PROVIDED TO THE PROJECT ENGINEER.

EROSION CONTROL SUPERVISOR:

IN ACCORDANCE WITH SPEC. 2573, THE CONTRACTOR WILL PROVIDE A CERTIFIED EROSION CONTROL SUPERVISOR IN GOOD STANDING WHO IS KNOWLEDGEABLE AND EXPERIENCED IN THE APPLICATION OF EROSION PREVENTION AND SEDIMENT CONTROL BEST MANAGEMENT PRACTICES.

THE EROSION CONTROL SUPERVISOR WILL WORK WITH THE PROJECT ENGINEER TO OVERSEE THE IMPLEMENTATION OF THE SWPPP AND THE INSTALLATION, INSPECTION, AND MAINTENANCE OF THE EROSION PREVENTION AND SEDIMENT CONTROL BMPS BEFORE, DURING, AND AFTER CONSTRUCTION UNTIL THE NOTICE OF TERMINATION (NOT) HAS BEEN FILED WITH THE MPCA.

THE EROSION CONTROL SUPERVISOR IS RESPONSIBLE FOR COMPLYING WITH ALL THE INSPECTION AND MAINTENANCE REQUIREMENTS STATED IN THE NPDES PERMIT PART IV.F. INSPECTIONS OF THE ENTIRE CONSTRUCTION SITE WILL OCCUR A MINIMUM OF ONCE EVERY SEVEN DAYS DURING ACTIVE CONSTRUCTION AND WITHIN 24 HOURS AFTER A RAINFALL EVENT GREATER THAN 0.5 INCHES IN 24 HOURS. THE EROSION CONTROL SUPERVISOR WILL THOROUGHLY INSPECT ALL EROSION PREVENTION AND SEDIMENT CONTROL BMPS TO ENSURE INTEGRITY AND EFFECTIVENESS OF EACH BMP. ALL INSPECTIONS AND MAINTENANCE CONDUCTED DURING CONSTRUCTION MUST BE RECORDED IN WRITING AND THESE RECORDS MUST BE RETAINED WITH THE SWPPP. INSPECTION REPORTS MUST BE SUBMITTED TO THE PROJECT ENGINEER IN A FORMAT THAT MEETS OR EXCEEDS THE PROJECT ENGINEERS EXPECTATIONS. RECORDS OF EACH INSPECTION AND MAINTENANCE ACTIVITY SHALL INCLUDE:

- A. DATE AND TIME OF INSPECTIONS,
- B. NAME OF PERSONS CONDUCTING INSPECTIONS,
- C. FINDINGS OF INSPECTIONS, INCLUDING RECOMMENDATIONS FOR CORRECTIVE ACTIONS,
- D. CORRECTIVE ACTIONS TAKEN INCLUDING DATES, TIMES, AND PARTY COMPLETING MAINTENANCE ACTIVITIES,
- E. DATE AND AMOUNT OF ALL RAINFALL EVENTS GREATER THAN 0.5 INCH IN 24 HOURS,
- F. DOCUMENTS AND CHANGES MADE TO THE SWPPP.

SOIL TYPES:

A PRELIMINARY GEOTECHNICAL EVALUATION REPORT WAS COMPLETED BY BRAUN INTERTEC AND INCLUDES SOIL BORINGS. THE GEOTECHNICAL EVALUATION REPORTS ARE INCLUDED AS ATTACHMENTS TO THE PROJECT MANUAL AND INCLUDES PARTICLE SIZE IDENTIFICATION. THE PROJECT SITE GENERALLY CONTAINS HIGH RELIEF TILL DEPOSITS.

MODIFICATIONS TO EXISTING CONDITIONS/DRAINAGE PATTERNS:

THE PROJECT IS WITHIN RILEY PURGATORY BLUFF CREEK WATERSHED. THE CHAN VIEW AREA IS WITHIN RICE MARSH LAKE SUBWATERSHED AND DRAINS SOUTH ALONG LAREDO, KIOWA, IROQUOIS, HURON, AND GREAT PLAINS INTO EXISTING STORM SEWER ALONG CHAN VIEW WHERE IT ROUTES OFFSITE INTO RICE MARSH LAKE. NORTH OF 76TH STREET, INCLUDING DEL RIO, SANTA FE TRAIL, AND 77TH STREET ARE WITHIN LOTUS LAKE SUBWATERSHED. THESE AREAS ARE CAPTURED IN EXISTING STORM SEWER AND ROUTE NORTH EAST TO LOTUS LAKE. THE STONE CREEK AREA IS WITHIN BLUFF CREEK SUBWATERSHED, THIS AREA IS CAPTURED IN EXISTING STORM SEWER AND ROUTED TO BLUFF CREEK.

SEQUENCE OF MAJOR CONSTRUCTION ACTIVITIES:

1. PLACE INLET PROTECTION ON ALL EXISTING INLETS.
2. PLACE TEMPORARY EROSION AND SEDIMENT CONTROLS SUCH AS EROSION CONTROL LOGS, SILT FENCE, CULVERT END CONTROLS, AND STORM DRAIN INLET PROTECTION.
3. CLEAR AND GRUB THE SITE. REMOVE PAVEMENTS, CURB AND GUTTER, AND OTHER REMOVAL ITEMS.
4. PLACE STABILIZED CONSTRUCTION EXITS.
5. PERFORM GRADING ACTIVITIES AND EXCAVATE STORM WATER BMPS.
6. PLACE UNDERGROUND UTILITY IMPROVEMENTS.
7. PLACE INLET PROTECTION ON ALL PROPOSED CATCH BASINS IMMEDIATELY AFTER PLACEMENT.
8. PLACE SEDIMENT CONTROL PROTECTION IMMEDIATELY AFTER CONSTRUCTION OF STORMWATER BMPS TO PROTECT BMP AREAS.
9. PLACE ALL OTHER TEMPORARY EROSION AND SEDIMENT CONTROLS SUCH AS RAPID STABILIZATION AND BIOROLLS.

SEQUENCE OF MAJOR CONSTRUCTION ACTIVITIES (CONTINUED):

10. CONSTRUCT CURB AND GUTTER, CONSTRUCT PAVEMENT, AND OTHER PROPOSED IMPROVEMENTS.
11. COMPLETE FINAL STABILIZATION.
12. REMOVE ALL TEMPORARY EROSION AND SEDIMENT CONTROL MEASURES.

PLAN SHEETS:

- | | |
|----------|--|
| 2 - 3 | STATEMENT OF ESTIMATED QUANTITIES |
| 47 - 66 | REMOVAL PLAN, EROSION CONTROL PLAN |
| 88 -116 | STORM SEWER PLAN & PROFILES AND LATERALS |
| 117 -136 | STREET CONSTRUCTION PLAN AND PROFILES |

RAINFALL DATA:

- | |
|--|
| 2-YEAR 24 HOUR STORM EVENT = 2.48 INCHES |
| 5-YEAR 24 HOUR STORM EVENT = 3.57 INCHES |
| 10-YEAR 24 HOUR STORM EVENT = 4.22 INCHES |
| 50-YEAR 24 HOUR STORM EVENT = 6.25 INCHES |
| 100-YEAR 24 HOUR STORM EVENT = 7.29 INCHES |

TOTAL DISTURBED AREA: 14.51 ACRES
TOTAL EXISTING IMPERVIOUS SURFACE AREA: 10.02 ACRES
TOTAL PROPOSED IMPERVIOUS SURFACE AREA: 10.20 ACRES
TOTAL PROPOSED NET CHANGE IN IMPERVIOUS SURFACE AREA: 0.18 ACRES

CALCULATIONS FOR PERMANENT STORMWATER FEATRES AND ADDITIONAL DESIGN INFORMATION CAN BE MADE AVAILABLE UPON REQUEST.

LONG TERM MAINTENANCE AND OPERATION

CITY OF CHANHASSEN IS RESPONSIBLE FOR LONG TERM OPERATION AND MAINTENANCE OF THE PERMANENT STORMWATER FEATURES.

MPCA CONTACT INFORMATION:

THE PROJECT ENGINEER AND CONTRACTOR ARE RESPONSIBLE FOR IMPLEMENTATION OF THE SWPPP AND INSTALLATION, INSPECTION, AND MALIGNANCE OF THE EROSION PREVENTION AND SEDIMENT CONTROL BMPS BEFORE, DURING AND AFTER CONSTRUCTION UNTIL THE NOTICE OF TERMINATION HAS BEEN FILED. MNDOT METRO DISTRICT WATER RESOURCES ARE ALSO AVAILABLE FOR TECHNICAL ASSISTANCE.

ORGANIZATION	CONTACT NAME	PHONE
WATER RESOUGRES (WRE) DESIGN	ADAM TJADEN	612-503-8531
MNDOT METRO WRE (EROSION CONTROL/MS4)	SARAH THOMPSON & RYAN RUPP	651-234-7539
MINNESOTA POLLUTION CONTROL AGENCY (MPCA)	HALEY BAUER	651-757-2768
MINNESOTA DEPARTMENT OF NATURAL RESOURCES	PETER LEETE	651-366-3634
CITY OF CHANHASSEN	JOE SEIDL	952-227-1168

MPCA DUTY OFFICER 24 HOUR EMERGENCY NOTIFCATION: 651-649-5451 OR 800-422-0798

GENERAL SWPPP NOTES FOR CONSTRUCTION ACTIVITY:

1. THE GENERAL CONTRACTOR IS RESPONSIBLE TO COMPLY WITH ALL ASPECTS OF THE NPDES CONSTRUCTION STORMWATER PERMIT AT ALL TIMES UNTIL THE NOTICE OF TERMINATION (NOT) HAS BEEN FILED WITH THE MPCA. THE CONTRACTOR WILL DEVELOP A CHAIN OF COMMAND WITH ALL OPERATORS ON THE SITE TO ENSURE THAT THE SWPPP WILL BE IMPLEMENTED AND STAY IN EFFECT UNTIL THE CONSTRUCTION PROJECT IS COMPLETE, THE ENTIRE SITE HAS UNDERGONE FINAL STABILIZATION, AND A NOTICE OF TERMINATION (NOT) HAS BEEN SUBMITTED TO THE MPCA.
2. THE CONTRACTOR WILL PREPARE A WRITTEN, NOT ORAL, WEEKLY SCHEDULE OF PROPOSED EROSION CONTROL ACTIVITIES FOR THE PROJECT ENGINEERS APPROVAL AS PER MN/DOT SPEC. 1717.
3. THE CONTRACTOR WILL PREPARE AND SUBMIT A SITE PLAN FOR THE ENGINEERS APPROVAL AS PER MN/DOT SPEC. 1717 FOR CONCRETE MANAGEMENT, WORK IN ENVIRONMENTALLY SENSITIVE AREAS, AREAS IDENTIFIED IN THE PLANS AS "SITE PLAN REQUIREMENT AREA." ANY WORK THAT WILL REQUIRE DEWATERING, THE STAGING OF INLET PROTECTION DEVICES OVER THE LIFE OF THE CONTRACT AND AS REQUESTED BY THE ENGINEER, ALL SITE PLANS MUST BE SUBMITTED TO THE ENGINEER IN WRITING. THE CONTRACTOR SHALL ALLOW A MINIMUM OF 7 DAYS FOR REVIEW AND APPROVE SITE PLAN SUBMITTALS. THE CONTRACTOR WILL NOT BE ALLOWED TO COMMENCE WORK FOR WHICH A SITE PLAN IS REQUIRED UNTIL APPROVAL HAS BEEN GRANTED BY THE ENGINEER. THE CONTRACTOR WILL NOT BE GIVEN ANY EXTRA TIME IN THE CONTRACT DUE TO THE UNTIMELY SUBMITTAL OF A SITE PLAN. THE CONTRACTOR SHALL SUBMIT A CONTRACTOR'S EROSION / SEDIMENT CONTROL SITE PLAN TO THE ENGINEER A MINIMUM OF 24 HOURS PRIOR TO THE FIRST PRE-CONSTRUCTION MEETING. THE CONTRACTOR'S EROSION / SEDIMENT CONTROL SITE PLAN SHALL INCLUDE:
 - A. THE NAME OF THE CONTRACTOR'S DESIGNATED EROSION CONTROL SUPERVISOR WITH 24-HOUR CONTACT INFORMATION. (I.E. PHONE NUMBER, EMAIL, ETC.)
 - B. NAME AND CONTACT INFORMATION FOR THE INDIVIDUAL(S) RESPONSIBLE FOR PERFORMING AND MAINTAINING THE SITE INSPECTION LOGS ON A WEEKLY BASIS (OR WITHIN 24 HOURS OF 0.5 INCHES OF A RAIN IN A 24 HOUR PERIOD).
 - C. NAME AND CONTACT INFORMATION OF THE INDIVIDUAL(S) RESPONSIBLE FOR TEMPORARY AND PERMANENT STABILIZATION.
 - D. NAME AND CONTACT INFORMATION OF THE INDIVIDUAL(S) WHO WILL BE RESPONSIBLE FOR EMERGENCY REPAIRS AND REPLACEMENTS.
 - E. LOCATION WHERE THE SWPPP DOCUMENT AND NPDES PERMIT WILL BE KEPT ON-SITE. THE DOCUMENT SHOULD BE ACCESSIBLE AT ALL TIMES AND AVAILABLE IN THE TIME OF ESSENCE.
 - F. WHERE AND HOW CONCRETE WASHOUT WILL OCCUR AND BE IN COMPLIANCE OF THE MINNESOTA POLLUTION CONTROL AGENCY'S (MPCA) MEMORANDUM "CONCRETE WASHOUT GUIDANCE".
 - G. LOCATION OF STOCKPILES OF NATIVE SOILS AND/OR BORROW MATERIALS AND INDICATE HOW STOCKPILES WILL BE KEPT IN COMPLIANCE WITH NPDES AND MPCA REQUIREMENTS.
 - H. LOCATION OF ANY TEMPORARY SEDIMENT BASINS AND TRAPS.
4. THE CONTRACTOR WILL COMPLY WITH THE REQUIREMENTS REGARDING POLLUTION PREVENTION MANAGEMENT DURING CONSTRUCTION, WHICH WILL INCLUDE, BUT NOT LIMITED TO PROVIDING:
 - A. CONCRETE WASHOUT AREAS FOR USE BY ALL SUBCONTRACTORS AND PROJECT PERSONNEL. LOCATION OF WASHOUT AREAS MUST BE IDENTIFIED BY SIGNAGE AND MUST BE AT LEAST 200' FROM SITE PLAN REQUIREMENT AREAS OR ENVIRONMENTALLY SENSITIVE AREAS, AND UTILIZE A LEAK-PROOF CONTAINMENT FACILITY OR IMPERMEABLE LINER THAT PREVENTS RUNOFF ONTO ADJACENT SOILS. AN ENGINEERED COLLECTION SYSTEM CAN ALSO BE USED IF IT IS APPROVED BY THE PROJECT ENGINEER.
 - B. SOLID WASTE COLLECTION AND REMOVAL
 - C. SECONDARY CONTAINMENT
 - D. SECURED HAZARDOUS WASTE STORAGE CONTAINERS
 - E. CHEMICAL SPILL KITS
 - F. PORTABLE RESTROOM FACILITIES THAT ARE ANCHORED TO PREVENT TIPPING

K:\TOW_Civil\City\CHANHASSEN\2024_CITY STREET REHAB-RECON\CONST\CAD\Plan Sheets\2024_PaveRehab_SWPPP.dwg February 29, 2024 - 6:56pm

No.	Date	Revisions	App.	DRAWING NAME 2024_PaveRehab_SWPPP	<p style="font-size: small;">11995 SINGLETREE LANE, SUITE 225, EDEN PRAIRIE, MN 55344 PHONE: 612-315-1272 WWW.KIMLEY-HORN.COM</p>	I HEREBY CERTIFY THAT THIS PLAN, SPECIFICATION OR REPORT WAS PREPARED BY ME OR UNDER MY DIRECT SUPERVISION AND THAT I AM A DULY LICENSED PROFESSIONAL ENGINEER UNDER THE LAWS OF THE STATE OF MINNESOTA. ADAM T. TJADEN DATE: 02/29/2024 MN LIC. NO. 59337		CITY OF CHANHASSEN 2024 CITY PAVEMENT REHABILITATION PROJECT STORMWATER POLLUTION PREVENTION PLAN	CITY PROJECT 24-01	SHEET NO. 44 188
				DESIGNED BY: ART						
				DRAWN BY: ART						
				CHECKED BY: ART						
				DATE: 02/29/2024						
				PROJECT NO. 24-01						

STORM WATER POLLUTION PREVENTION PLAN (SWPPP) NARRATIVE (CONTINUED)

5. CHEMICALS MUST BE KEPT IN A SECURE STORAGE AREA WHEN NOT IN USE. CHEMICAL STORAGE CONTAINERS MUST HAVE SECONDARY CONTAINMENT WHEN BEING USED OR STORED ON THE PROJECT SITE. CHEMICAL SPILLS OF ANY KIND (OIL, FUEL, FERTILIZER, ETC.) MUST BE CLEANED UP AND REMOVED FROM THE SITE IMMEDIATELY. THE CONTRACTOR MUST HAVE A SPILL KIT ON SITE AT ALL TIMES. THE FOLLOWING GOOD HOUSEKEEPING SPILL PREVENTION PRACTICES WILL BE FOLLOWED ONSITE DURING THE CONSTRUCTION PROJECT:
 - A. AN EFFORT WILL BE MADE TO STORE ONLY ENOUGH PRODUCTS REQUIRED TO DO THE JOB.
 - B. ALL MATERIALS STORED ONSITE WILL BE STORED IN A NEAT, ORDERLY MANNER IN THEIR APPROPRIATE CONTAINERS AND, IF POSSIBLE, UNDER A ROOF OR OTHER ENCLOSURE WITH SECONDARY CONTAINMENT.
 - C. PRODUCTS WILL BE KEPT IN THEIR ORIGINAL CONTAINERS WITH THE ORIGINAL MANUFACTURER'S LABEL.
 - D. SUBSTANCES WILL NOT BE MIXED WITH ONE ANOTHER UNLESS RECOMMENDED BY THE MANUFACTURER.
 - E. WHENEVER POSSIBLE, ALL OF A PRODUCT WILL BE USED UP BEFORE DISPOSING OF THE CONTAINER.
 - F. MANUFACTURERS' RECOMMENDATIONS FOR PROPER USE AND DISPOSAL WILL BE FOLLOWED.
 - G. THE CONTRACTOR'S SITE SUPERINTENDENT WILL INSPECT DAILY TO ENSURE PROPER USE AND DISPOSAL OF MATERIALS ONSITE.
- THE FOLLOWING PRACTICES WILL BE USED TO REDUCE THE RISKS ASSOCIATED WITH HAZARDOUS MATERIALS:
 - A. PRODUCTS WILL BE KEPT IN THEIR ORIGINAL CONTAINERS UNLESS CANNOT BE RESEALED.
 - B. ORIGINAL LABELS AND MATERIAL SAFETY DATA SHEETS WILL BE RETAINED ON SITE AND ACCESSIBLE AT ALL TIMES; THEY CONTAIN IMPORTANT PRODUCT AND SAFETY INFORMATION.
 - C. IF SURPLUS PRODUCT MUST BE DISPOSED OF, MANUFACTURERS' OR LOCAL AND STATE RECOMMENDED METHODS FOR PROPER DISPOSAL WILL BE FOLLOWED.
- IN ADDITION TO THE GOOD HOUSEKEEPING AND MATERIAL MANAGEMENT PRACTICES DISCUSSED IN THE PREVIOUS SECTIONS OF THIS PLAN, THE FOLLOWING PRACTICES WILL BE FOLLOWED FOR SPILL PREVENTION AND CLEANUP:
 - A. MANUFACTURERS' RECOMMENDED METHODS FOR SPILL CLEANUP WILL BE CLEARLY POSTED AND SITE PERSONNEL WILL BE MADE AWARE OF THE PROCEDURES AND THE LOCATION OF THE INFORMATION AND CLEANUP SUPPLIES.
 - B. MATERIALS AND EQUIPMENT NECESSARY FOR SPILL CLEANUP WILL BE KEPT IN A MATERIAL STORAGE AREA LOCATED ONSITE. EQUIPMENT AND MATERIALS WILL INCLUDE BUT NOT BE LIMITED TO BROOMS, DUST PANS, MOPS, RAGS, GLOVES, GOGGLES, CAT LITTER, SAND, SAWDUST, AND PLASTIC AND METAL TRASH CONTAINERS SPECIFICALLY FOR THIS PURPOSE.
 - C. ALL SPILLS WILL BE CLEANED UP IMMEDIATELY AFTER DISCOVERY.
 - D. THE SPILL AREA WILL BE KEPT WELL VENTILATED AND PERSONNEL WILL WEAR APPROPRIATE PROTECTIVE CLOTHING TO PREVENT INJURY FROM CONTACT WITH A HAZARDOUS SUBSTANCE.
 - E. SPILLS OF TOXIC OR HAZARDOUS MATERIAL WILL BE REPORTED TO THE APPROPRIATE STATE OR LOCAL GOVERNMENT AGENCY, REGARDLESS OF THE SIZE. IN ADDITION TO REPORTING TO LOCAL AUTHORITIES, REPORT SPILLS TO THE MINNESOTA POLLUTION CONTROL AGENCY (STATE DUTY OFFICER: 800-422-0798 OR 651-297-8610). ANY SPILLS ABOVE THE REPORTABLE QUANTITIES LIMITS IN THE CODE OF FEDERAL REGULATIONS (CFR), TITLE 40, PART 302 SHALL BE REPORTED TO THE EPA NATIONAL RESPONSE CENTER (800-424-8802). THE REPORT WILL INCLUDE MEASURES TO PREVENT SPILLS FROM REOCCURRING AND INFORMATION REGARDING HOW TO REMEDIATE SPILLS IF A SIMILAR OCCURRENCE HAPPENS. A DESCRIPTION OF THE SPILL, WHAT CAUSED IT, AND THE CLEANUP MEASURES WILL ALSO BE INCLUDED.
 - F. THE CONTRACTOR'S EROSION CONTROL SUPERVISOR SHALL BE THE SPILL PREVENTION AND CLEANUP COORDINATOR.
 - G. SPILLS WILL BE STUDIED TO UNDERSTAND WHY THEY OCCURRED AND PREVENTIVE METHODS WILL BE CREATED TO ENSURE SIMILAR SPILLS TO DO NOT OCCUR IN THE FUTURE.
6. ALL ONSITE VEHICLES WILL BE MONITORED FOR LEAKS AND RECEIVE REGULAR PREVENTIVE MAINTENANCE TO REDUCE THE CHANCE OF LEAKAGE. PETROLEUM PRODUCTS WILL BE STORED IN TIGHTLY SEALED CONTAINERS WHICH ARE CLEARLY LABELED. ANY ASPHALT BASED MATERIALS USED ONSITE WILL BE APPLIED AND STORED ACCORDING TO THE MANUFACTURER'S RECOMMENDATIONS. ANY SPILLS PETROLEUM PRODUCTS OF 5 GALLONS OR MORE SHALL BE REPORTED TO THE MINNESOTA POLLUTION CONTROL AGENCY AT 651-297-8610.
7. WHENEVER POSSIBLE, VEHICLE REFUELING AND MAINTENANCE SHOULD NOT BE PERFORMED ON THE CONSTRUCTION SITE. HOWEVER, ANY VEHICLE REFUELING OR MAINTENANCE THAT MUST TAKE PLACE ON THE CONSTRUCTION SITE MUST HAVE PROPER SPILL PREVENTION CONTROLS IN PLACE PRIOR TO COMMENCING WORK.
8. THE CONTRACTOR IS RESPONSIBLE FOR CREATING AND FOLLOWING A WRITTEN DISPOSAL PLAN FOR ALL WASTE MATERIALS INCLUDING HAZARDOUS AND SANITARY WASTE. THE PLAN WILL INCLUDE HOW THE MATERIAL WILL BE DISPOSED OF AND THE LOCATION OF THE DISPOSAL SITE. SUBMIT TO THE ENGINEER.
9. ALL PAINT AND CLEANING SOLVENT CONTAINERS WILL BE TIGHTLY SEALED AND STORED WHEN NOT REQUIRED FOR USE. EXCESS PAINT AND SOLUTIONS WILL NOT BE DISCHARGED TO THE STORM SEWER SYSTEM BUT WILL BE PROPERLY DISPOSED OF ACCORDING TO MANUFACTURERS' INSTRUCTIONS OR STATE AND LOCAL REGULATIONS.
10. CONCRETE, CONCRETE TOOLS, AND CONCRETE TRUCKS ALL MUST WASH OUT IN A DESIGNATED AREA. THE DESIGNATED AREA MUST BE CLEARLY IDENTIFIED ON THE SITE AND COMMUNICATED TO ALL PERSONNEL INVOLVED WITH CAST-IN-PLACE CONCRETE AS THE WASHOUT AREA. THIS DESIGNATED AREA MUST MEET THE MPCA REGULATIONS OF A DEFINED CONCRETE WASHOUT AREA. THE FOLLOWING THREE OPTIONS ARE CONSIDERED AN APPROVED METHOD:
 - A. KEEPING ALL CONCRETE WASHOUT SELF-CONTAINED AND RETURNED TO AN INDUSTRIAL SITE TO BE DISPOSED OF IN A MPCA APPROVED MANNER.
 - B. PROVIDING A PREFABRICATED CONCRETE WASHOUT CONTAINER THAT ALL CONCRETE WASHOUT CAN BE COLLECTED IN. THESE CONTAINERS SHOULD BE MAINTAINED ON A REGULAR BASIS.
 - C. CREATING A SELF-INSTALLED WASHOUT FACILITY WITH AN IMPERMEABLE LINER. AN ENGINEERED CLAY LINER WILL BE CONSIDERED AN IMPERMEABLE LINER. FOR ADDITIONAL INFORMATION ON CONCRETE WASHOUT REGULATIONS, PLEASE SEE THE MPCA'S MEMORANDUM "CONCRETE WASHOUT GUIDANCE".
11. BURNING OF ANY MATERIAL IS NOT ALLOWED WITHIN PROJECT BOUNDARY.
12. THE EROSION PREVENTION AND SEDIMENT CONTROL BMPs SHALL BE INSTALLED AS NECESSARY TO MINIMIZE EROSION FROM DISTURBED SURFACES AND CAPTURE SEDIMENT ONSITE. ALL EROSION CONTROL MEASURES SHALL BE IN PLACE PRIOR TO ANY REMOVAL WORK AND/OR GROUND DISTURBING ACTIVITIES COMMENCE AND SHALL BE MAINTAINED UNTIL THE POTENTIAL FOR EROSION HAS BEEN ELIMINATED. THE FOLLOWING CONTROL MEASURES WILL BE COORDINATED WITH CONSTRUCTION ACTIVITIES:
 - A. THE STABILIZED CONSTRUCTION ENTRANCE/EXIT SHALL BE THE FIRST PROJECT ITEM INSTALLED
 - B. SILT FENCE SHALL BE CONSTRUCTED PRIOR TO ANY SOIL DISTURBANCE AND SHALL REMAIN IN PLACE UNTIL PERMANENT STABILIZATION HAS TAKEN PLACE;
 - C. STORM SEWER INLET PROTECTION DEVICES AND STORM SEWER OUTFALL STABILIZATION SHALL BE INSTALLED PRIOR TO ANY SOIL DISTURBANCE AND SHALL REMAIN IN PLACE UNTIL PERMANENT STABILIZATION HAS TAKEN PLACE.
 - D. CLEARING, GRADING AND PAVEMENT REMOVAL WILL NOT OCCUR IN AN AREA UNTIL IT IS NECESSARY FOR CONSTRUCTION TO PROCEED;
 - E. EROSION AND SEDIMENT CONTROL DEVICES WILL BE SATISFACTORILY MAINTAINED UNTIL THE CONSTRUCTION IS COMPLETED AND THE POTENTIAL FOR EROSION HAS PASSED.
13. SEDIMENT CONTROL DEVICES MUST BE ESTABLISHED ON ALL DOWN GRADIENT PERIMETERS BEFORE ANY UP GRADIENT LAND DISTURBING ACTIVITIES BEGIN. SEDIMENT CONTROL DEVICES INCLUDE, BUT ARE NOT LIMITED TO:
 - A. PERIMETER CONTROL SHALL BE LOCATED ON THE CONTOUR TO CAPTURE OVERLAND. LOW-VELOCITY SHEET FLOWS DOWN GRADIENT OF ALL EXPOSED SOILS AND PRIOR TO DISCHARGING TO SURFACE WATERS WITH THE BMP J-HOOKED AT A MAXIMUM OF 100 FOOT INTERVALS AND SHALL CONTAIN NO MORE THAN ¼ ACRE OF DRAINAGE AREA.
 - B. SEDIMENT DAMAGE FROM STOCKPILES WILL BE MINIMIZED BY PLACING A ROW OF SILT FENCE A MINIMUM 5 FEET FROM THE TOE. IF THERE IS NOT ADEQUATE PROJECT AREA TO PLACE THE SILT FENCE MORE THAN 5 FEET FROM THE TOE OF THE SLOPE THE CONTRACTOR MAY SUBMIT AN ALTERNATIVE FOR APPROVAL BY THE PROJECT ENGINEER.
14. STORM SEWER INLETS WILL BE PROTECTED AT ALL TIMES WITH THE APPROPRIATE INLET PROTECTION FOR EACH SPECIFIC PHASE OF CONSTRUCTION. INLET PROTECTION DEVICES MAY NEED TO BE PLACED MULTIPLE TIMES IN THE SAME LOCATION OVER THE LIFE OF THE CONTRACT. INLET PROTECTION DEVICES WILL BE PAID FOR ONCE PER INLET REGARDLESS OF THE NUMBER OF TIMES THE BMP IS PLACED. ALL STORM SEWER INLET PROTECTION DEVICES WILL BE KEPT IN GOOD FUNCTIONAL CONDITION AT ALL TIMES. IF THE PROJECT ENGINEER DEEMS AN INLET PROTECTION DEVICE TO BE NONFUNCTIONAL, IN POOR CONDITION, INEFFECTIVE OR NOT APPROPRIATE FOR THE CURRENT CONSTRUCTION ACTIVITIES IT WILL BE REPLACED WITH A SUITABLE ALTERNATIVE AT NO COST TO THE CITY. FAILURE TO PERFORM WILL RESULT IN DEDUCT.
15. THE CONTRACTOR WILL PLACE CONSTRUCTION EXITS, AS NECESSARY, TO PREVENT TRACKING OF SEDIMENT ONTO PAVED SURFACES AND IN COMPLIANCE WITH PART IV OF THE NPDES PERMIT. CONSTRUCTION EXITS WILL BE SUFFICIENTLY SIZED AND MAINTAINED TO PREVENT TRACK OUT. TYPE 5 MULCH (SLASH MULCH) OR AN APPROVED ENGINEERED PRODUCT WILL BE ALLOWED FOR CONSTRUCTION EXITS IN LIEU OF CRUSHED ROCK. THIS WORK WILL BE PAID FOR AS A LUMP SUM OR AS INDICATED ELSE WHERE IN THE PLAN.
16. THE CONTRACTOR MUST USE METHODS AND OPERATION PROCEDURES THAT PREVENT DISCHARGE OR PLACEMENT OF BITUMINOUS GRINDINGS, CUTTINGS, MILLINGS, AND OTHER BITUMINOUS WASTES FROM AREAS OF EXISTING OR FUTURE VEGETATED SOILS, AND ALL WATER CONVEYANCE SYSTEMS, INCLUDING INLETS.
17. THE CONTRACTOR MUST USE METHODS AND OPERATIONAL PROCEDURES THAT PREVENT CONCRETE DUST, PARTICLES, SAW CUT SLURRY, PLANING WASTE AND OTHER CONCRETE WASTES FROM LEAVING CITY RIGHT-OF-WAY. DEPOSITING IN EXISTING OR FUTURE VEGETATED AREAS OR ENTERING STORMWATER CONVEYANCE SYSTEM INCLUDING INLETS AND CURB FLOW LINES.
18. DITCHES AND EXPOSED SOILS MUST BE KEPT IN AN EVEN ROUGH GRADED CONDITION IN ORDER TO BE ABLE TO APPLY EROSION CONTROL MULCHES AND BLANKETS.
19. ALL EXPOSED SOIL AREAS SHALL BE STABILIZED IMMEDIATELY AND MUST BE TEMPORARILY OR PERMANENTLY STABILIZED NO MORE THAN 7 DAYS AFTER CONSTRUCTION ACTIVITY ON THAT PORTION OF THE SITE HAS TEMPORARILY OR PERMANENTLY CEASED. IN MANY INSTANCES, THIS WILL REQUIRE STABILIZATION TO OCCUR MORE THAN ONCE DURING ROUGH GRADING. RAPID STABILIZATION METHOD 3 WILL BE USED TO PROVIDE TEMPORARY COVER IN THESE AREAS AS APPROPRIATE.
20. THE NORMAL WETTED PERIMETER OF ANY TEMPORARY OR PERMANENT DRAINAGE DITCH THAT DRAINS WATER FROM THE CONSTRUCTION SITE, OR DIVERTS WATER AROUND THE CONSTRUCTION SITE, MUST BE STABILIZED WITHIN 200 LINEAL FEET (100 LINEAL FEET IF WITHIN 1 MILE OF AND DRAINS TO A SPECIAL OR IMPAIRED WATER) FROM THE PROPERTY EDGE OR POINT OF DISCHARGE TO ANY SURFACE WATER. STABILIZATION MUST OCCUR WITHIN 24 HOURS OF CONNECTION TO A SURFACE WATER, EXISTING GUTTER, STORM SEWER INLET, DRAINAGE DITCH OR OTHER STORMWATER CONVEYANCE SYSTEM ACCORDING TO SPEC 1717. RAPID STABILIZATION METHOD 4 WILL BE USED TO STABILIZE THESE AREAS. THE REMAINDER OF THE DITCH MUST BE STABILIZED WITHIN 7 DAYS OF CONNECTING TO THE SURFACE WATER. PERMANENT EROSION CONTROL BLANKET OR RAPID STABILIZATION METHOD 4 WILL BE USED TO STABILIZE THESE AREAS. DISC ANCHORED MULCH AND HYDRAULIC SOIL STABILIZERS ARE NOT ALLOWED TO BE USED FOR PERMANENT DITCH STABILIZATION.
21. OUTLETS INTO SURFACE WATERS SHALL BE STABILIZED WITH ENERGY DISSIPATION WITHIN 24 HOURS OF BEING CONSTRUCTED.
22. ALL EXPOSED SOIL AREAS WILL BE STABILIZED PRIOR TO THE ONSET OF WINTER, ANY WORK STILL BEING PERFORMED WILL BE SNOW MULCHED, SEEDED, OR BLANKETED WITHIN THE TIME FRAMES IN THE NPDES PERMIT.
23. THE CONTRACTOR SHALL COMPLY WITH THE FOLLOWING INSPECTION AND MAINTENANCE REQUIREMENTS:
 - A. SILT FENCE MUST BE REPAIRED, REPLACED OR SUPPLEMENTED WHEN IT BECOMES NON-FUNCTIONAL OR SEDIMENT REACHES 1/3 THE HEIGHT OF THE SILT FENCE. REPAIRS MUST BE MADE WITHIN 24 HOURS OF DISCOVERY.
 - B. INLET PROTECTION DEVICES SHOULD BE REPAIRED WHEN THEY BECOME NON-FUNCTIONAL OR SEDIMENT REACHES 1/3 THE HEIGHT AND/OR DEPTH OF THE DEVICE.
 - C. TEMPORARY SEDIMENT BASIN MUST HAVE THE SEDIMENT REMOVED ONCE THE SEDIMENT HAS REACHED ½ THE STORAGE VOLUME WITHIN 72 HOURS OF DISCOVERY.
 - D. TRACKED SEDIMENT MUST BE REMOVED WITHIN 24 HOURS OF DISCOVERY OF TRACKING ONTO PAVED SURFACES.
 - E. ALL OTHER NON-FUNCTIONAL BMPs MUST BE REPAIRED, REPLACED, OR SUPPLEMENTED WITHIN 24 HOURS OF DISCOVERY.
 - F. CONTRACTOR IS RESPONSIBLE FOR MAINTAINING ALL BMPs UNTIL WORK HAS BEEN COMPLETED, SITE HAS GONE UNDER FINAL STABILIZATION, AND THE NOTICE OF TERMINATION HAS BEEN SUBMITTED TO THE MPCA IN ACCORDANCE WITH PART 11.B.5 OF THE CONSTRUCTION GENERAL PERMIT.
24. IF SEDIMENT DEPOSITS IN A WATER OF THE STATE, THE MATERIAL MUST BE REMOVED WITHIN 7 DAYS.
25. PAVEMENT SURFACES SHALL BE SWEEPED WITHIN 24 HOURS OF DISCOVERY OF SEDIMENT OR TRACKING ONTO PAVEMENT THAT DRAINS TO CURB, INLETS, DITCHES OR PONDS. PAVEMENT SHALL BE LIGHTLY WETTED PRIOR TO SWEEPING. THIS WORK IS INCIDENTAL TO THE PROJECT.
26. TEMPORARY DEWATERING ACTIVITIES MAY BE REQUIRED FOR THE ROADWAY CONSTRUCTION AND UTILITY WORK. THEREFORE IT IS POSSIBLE THAT A PERMIT FOR THE TEMPORARY APPROPRIATION OF WATERS OF THE STATE, NON-IRRIGATION FROM MNDNR WILL BE REQUIRED FOR THIS PROJECT. THE CONTRACTOR WILL BE RESPONSIBLE FOR OBTAINING THIS PERMIT. ALL TEMPORARY DEWATERING SHALL BE DISCHARGED TO AN APPROVED LOCATION FOR TREATMENT PRIOR TO DISCHARGE TO THE RECEIVING WATER. THE CONTRACTOR IS REQUIRED TO SUBMIT SITE PLANS TO THE ENGINEER FOR APPROVAL PRIOR TO COMMENCING WORK ACCORDING TO SPEC 1717.
27. BASIN DRAINING ACTIVITIES OF TURBID OR SEDIMENT LADEN WATER WILL BE DISCHARGED TO TEMPORARY SEDIMENT BASINS WHENEVER POSSIBLE. IN THE EVENT THAT IT IS NOT POSSIBLE TO DISCHARGE THE SEDIMENT LADEN WATER TO A TEMPORARY SEDIMENT BASIN, THE WATER MUST BE TREATED SO THAT IT DOES NOT CAUSE A NUISANCE CONDITION IN THE RECEIVING WATERS OR TO THE DOWNSTREAM LANDOWNERS.
28. IT IS THE DESIGNER'S INTENT THAT THE CONTRACTOR BUILD PONDS AND INSTALL EROSION CONTROL BEFORE PUTTING THEM IN ACTIVE SERVICE TO THE MAXIMUM EXTENT PRACTICAL. ALL PONDS FOR THE PROJECT WILL BE SUBJECT TO THE SITE PLAN REQUIREMENT AREA EROSION CONTROL SCHEDULE AS PER 1717.
29. THE CONTRACTOR MAY NOT DRIVE ANY EQUIPMENT ON FINISHED POND BOTTOMS OR POND CORNERS. IF DISTURBED, POND BOTTOM AND POND CORNERS MUST BE RESTORED TO PRE-EXISTING CONDITIONS WITHIN 24 HOURS. ANY RUTS OR DAMAGED TURF THAT COULD CREATE SEDIMENT DISCHARGE TO POND BOTTOMS MUST BE REPAIRED WITHIN 24 HOURS.
30. ANY SUBSURFACE DRAINAGE TILES DAMAGED DURING CONSTRUCTION SHALL BE REPAIRED, REPLACED OR REROUTED AND CONNECTED TO THE EXISTING TILE OR DRAINAGE SYSTEM TO ENSURE THAT EXISTING UPLAND DRAINAGE IS PERPETUATED. THIS SHOULD BE DONE TO THE APPROVAL AND SATISFACTION OF THE ENGINEER.
31. TILLING FOR BEDS OR TREE HOLES MUST BE PLANTED AND MULCHED WITH WOODCHIP WITHIN 7 DAYS OR STRAW MULCHED UNTIL PLANTING OPERATIONS CAN BE COMPLETED.
32. ANY POND CORNERS OPENED DUE TO TILING FOR SHRUB BEDS OR TREE HOLES MUST BE PLANTED AND MULCHED WITH WOODCHIP WITHIN 24 HOURS OR STRAW MULCHED UNTIL PLATING OPERATIONS CAN BE COMPLETED.
33. ALL PERMANENT STORMWATER BASINS USED AS TEMPORARY SEDIMENT TRAPS WILL BE CLEANED OUT TO THE DESIGN CAPACITY AFTER ALL UPGRADIENT LAND DISTURBING ACTIVITY IS COMPLETED.

K:\TOW_Civil\City\CHANHASSEN\2024_CITY STREET REHAB-RECONSTRUCT\CAD\Plan Sheets\2024_PaveRehab_SWPPP.dwg February 29, 2024 - 6:56pm

No.	Date	Revisions	App.	DRAWING NAME
				2024_PaveRehab_SWPPP
				DESIGNED BY: ART
				DRAWN BY: ART
				CHECKED BY: ART
				DATE: 02/29/2024
				PROJECT NO. 24-01

Kimley»Horn

11995 SINGLETREE LANE, SUITE 225, EDEN PRAIRIE, MN 55344
 PHONE: 612-315-1272
 WWW.KIMLEY-HORN.COM

I HEREBY CERTIFY THAT THIS PLAN, SPECIFICATION OR REPORT WAS PREPARED BY ME OR UNDER MY DIRECT SUPERVISION AND THAT I AM A DULY LICENSED PROFESSIONAL ENGINEER UNDER THE LAWS OF THE STATE OF MINNESOTA.

Adam R. Waden
 ADAM R. WADEN
 DATE: 02/29/2024 MN LIC. NO. 59337



CITY OF CHANHASSEN
 2024 CITY PAVEMENT
 REHABILITATION PROJECT

STORMWATER POLLUTION
 PREVENTION PLAN

CITY PROJECT	24-01	SHEET NO.
		45
		188

STABILIZATION TIME FRAMES

AREA	TIME FRAME	NOTES
LAST 200 LINEAL FEET OF DRAINAGE DITCH OR SWALE	WITHIN 24 HRS. OF CONNECTION TO SURFACE WATER OR PROPERTY EDGE	1, 2, 3
REMAINING PORTIONS OF DRAINAGE DITCH OR SWALE	7 DAYS	1, 3
PIPE AND CULVERT OUTLETS	24 HOURS	
EXPOSED SOILS AND STOCKPILES	7 DAYS	1
WITHIN 200 LINEAL FEET OF A PUBLIC WATER	24 HOURS	7

- INITIATE STABILIZATION IMMEDIATELY WHEN CONSTRUCTION HAS TEMPORARILY OR PERMANENTLY CEASED ON ANY PORTION OF THE SITE. COMPLETE STABILIZATION WITHIN THE TIME FRAME LISTED IN THE CONTRACT. IN MANY INSTANCES THIS WILL REQUIRE STABILIZATION TO OCCUR MORE THAN ONCE DURING THE COURSE OF THE PROJECT. TEMPORARY SOIL STOCKPILES WITHOUT SIGNIFICANT CLAY OR SILT AND STOCKPILED AND CONSTRUCTED ROAD BASE ARE EXEMPT FROM THE STABILIZATION REQUIREMENT.
- STABILIZE WETTED PERIMETER OF DITCH (I.E. WHERE THE DITCH GETS WET).
- APPLICATION OF MULCH, HYDROMULCH, TACKIFIER, AND POLYACRYLAMIDE ARE NOT ACCEPTABLE STABILIZATION METHODS IN THESE AREAS.
- STABILIZE ALL AREAS OF THE SITE PRIOR TO THE ONSET OF WINTER. ANY WORK STILL BEING PERFORMED WILL BE SNOW MULCHED, SEEDED, AND BLANKETED WITHIN THE TIME FRAMES IN THE NPDES PERMIT.
- TOPSOIL BERMS MUST BE STABILIZED IN ORDER TO BE CONSIDERED PERIMETER CONTROL BMPs. USE RAPID STABILIZATION METHOD 2, 3, OR 4 AS DIRECTED BY THE CONSTRUCTION REPRESENTATIVE. THE SEED MIX USED IN THE RAPID STABILIZATION MAY BE SUBSTITUTED AS FOLLOWS:
 - SINGLE YEAR CONSTRUCTION BETWEEN MAY 1 – AUGUST 1, SEED WITH SEED MIXTURE 21-111
 - SINGLE YEAR CONSTRUCTION BETWEEN AUGUST 1 AND OCTOBER 31, SEED WITH SEED MIXTURE 21-112
 - MULTI YEAR CONSTRUCTION 22-1117. KEEP DITCHES AND EXPOSED SOILS IN AN EVEN ROUGH GRADED CONDITION IN ORDER TO BE ABLE TO APPLY EROSION CONTROL MULCHES, HYDROMULCHES, AND BLANKETS.8. SEE WATER RESOURCES NOTES FOR A LIST OF PUBLIC WATER EXCLUSION DATES. TWENTY-FOUR HOUR STABILIZATION REQUIREMENT ONLY APPLIES DURING THE EXCLUSION DATES.
- THE FOLLOWING TYPES OF WATERS HAVE WORK IN WATER EXCLUSIONS. NO WORK IN THE WATER IS ALLOWED DURING THE EXCLUSION DATES. SEE DNR PERMIT FOR WHICH WATERBODIES THIS APPLIES TO.
- THE FOLLOWING TABLE LISTS PUBLIC WATERS EXCLUSION DATES. TWENTY FOUR HOUR STABILIZATION REQUIREMENT ONLY APPLIES DURING THE EXCLUSION DATES.

WATERBODY	EXCLUSION DATES
LAKES	APRIL 1 – JUNE 30
NON-TROUT STREAMS	MARCH 15 – JUNE 15
TROUT STREAMS	SEPTEMBER 1 – APRIL 1

WATER RESOURCES NOTES

THESE NOTES ALONG WITH THE STORMWATER POLLUTION PREVENTION PLAN (SWPPP) NARRATIVE ARE INTENDED TO GIVE INFORMATION ON CRITICAL DRAINAGE FEATURES, NATURAL RESOURCES AND CONTRACTOR OPERATIONS THAT MAY IMPACT DRAINAGE AND NATURAL RESOURCES.

- THE SIZE AND ELEVATION OF STORM SEWER PIPES, INLETS, PERMEABLE DITCH BLOCKS, AND OVERFLOW DEVICES HAVE BEEN SPECIFICALLY DESIGNED TO CONFORM TO PROJECT DESIGN STANDARDS, MINNESOTA POLLUTION CONTROL AGENCY (MPCA), AND WATERSHED DISTRICT REQUIREMENTS. THE PROJECT'S FINAL DRAINAGE REPORT CONTAINS A SITE MAP WITH EXISTING AND FINAL GRADES, INCLUDING DRAINAGE AREA BOUNDARIES, DIRECTIONS OF FLOW AND ALL DISCHARGE POINTS WHERE STORMWATER IS LEAVING THE SITE OR ENTERING A SURFACE WATER, AND IDENTIFICATION OF SURFACE WATERS WITHIN 1 MILE OF THE PROJECT THAT RECEIVE RUNOFF FROM THE PROJECT. THE REPORT ALSO INCLUDES INFORMATION RELATING TO IMPERVIOUS SURFACE CHANGES AND SOIL TYPES. THERE ARE NO STEEP SLOPE AREAS OR POLLUTANT GENERATING ACTIVITIES WITHIN THE PROJECT LIMITS. CHANGING THE DIRECTION OF FLOW FROM WHAT IS SHOWN ON THE PLANS MAY CAUSE PROBLEMS OFF THE PROJECT AND COULD MEAN THE PROJECT IS OUT OF COMPLIANCE WITH APPROVED PERMITS. ANY CHANGES TO THE SIZE, ELEVATION OR DIRECTION OF FLOW OF THE DRAINAGE SYTEM MUST BE APPROVED BY THE WATER RESOURCES DESIGNER.
- THE FOLLOWING PERMITS AND APPROVALS APPLY TO THIS PROJECT:
 - NPDES – THE CONTRACTOR IS RESPONSIBLE FOR COMPLETING THE ONLINE FORM AND SUBMITTING TO THE MPCA PRIOR TO COMMENCING WORK ON SITE
 - RILEY PURGATORY BLUFF CREEK WATERSHED DISTRICT PERMIT – THE OWNER IS RESPONSIBLE FOR COMPLETING THE PERMIT APPLICATION FORM, BUT THE CONTRACTOR IS RESPONSIBLE FOR MEETING THE CONSTRUCTION REQUIREMENTS OF THE PERMIT.
- SUBSOIL ALL DISTURBED GREEN SPACES EXCEPT AS LISTED IN MNDOT 2574.3A.5.
- PERFORM POST INSTALLATION MANDREL TESTING OF ALL PLASTIC PIPE.
- WITHIN AREAS WHERE PERMEABLE DITCH BLOCKS, FILTRATION BASINS AND INFILTRATION BASINS ARE CONSTRUCTED, ONLY TRACKED VEHICLES MAY BE USED. WHEELED VEHICLES ARE PROHIBITED FROM THESE AREAS IN ORDER TO LIMIT THE COMPACTION OF THE EXISTING AND INSTALLED ENGINEERED SOILS. EXTRA CARE SHOULD BE TAKEN TO AVOID DISCHARGE OF CONSTRUCTION SEDIMENT TO THESE DRAINAGE FEATURES. IN THE EVENT THAT SEDIMENT IS DISCHARGED ONTO THE EXISTING SOILS PRECEDING PLACEMENT OF ENGINEERED SOILS OR ONTO THE SURFACE OF ENGINEERED SOILS, THE DAMAGED AREAS WILL BE REPLACED WITH ENGINEERED SOILS. IF THESE AREAS BECOME COMPACTED, THE CONTRACTOR WILL SUBSOIL THE BASIN, IN ACCORDANCE WITH MNDOT SPECIFICATION 2105, INSTALL ADDITIONAL ENGINEERED SOILS, OR USE OTHER METHODS RECOMMENDED BY THE ENGINEER AT NO COST TO THE OWNER. THE CONTRACTOR WILL THEN VERIFY USING A DOUBLE RING INFILTRMETER THAT THE BASIN WILL FUNCTION AS DESIGNED.
- SUBSOILING SHALL NOT BE APPLIED TO THIS PROJECT, EXCEPT IN THE CONDITION DESCRIBED IN NOTE 5 ABOVE.

MPCA's Construction Stormwater Special Waters Search

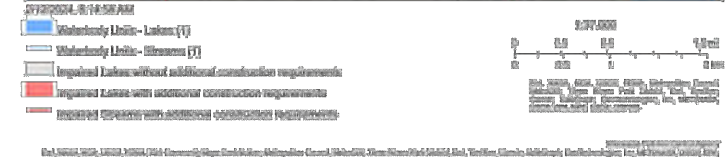
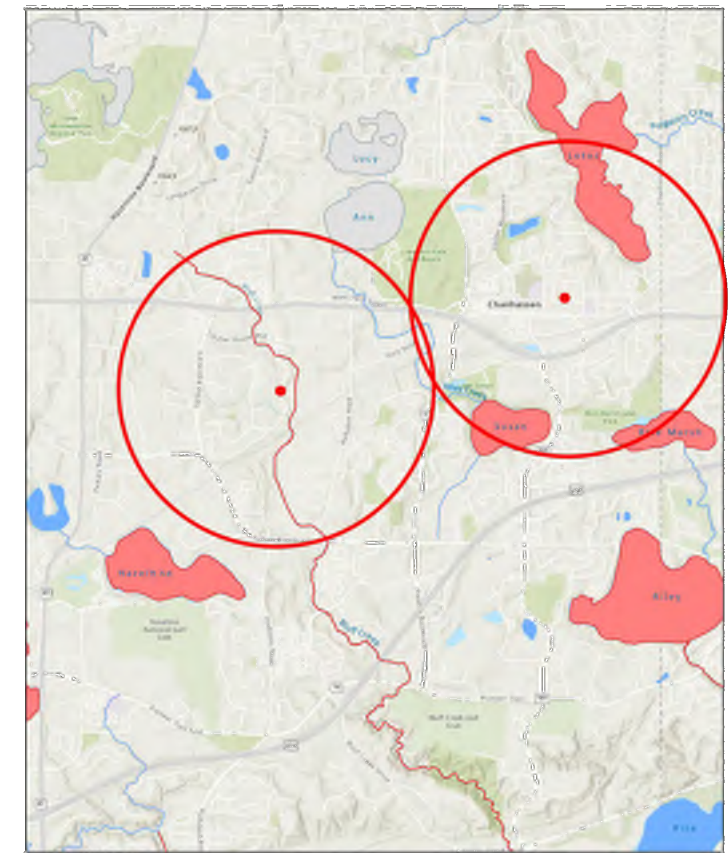

IMPAIRED WATERS MAP

K:\TOW_Civil\Civil\CHANHASSEN\2024_CITY STREET REHAB-RECONSTRUCT\CAD\Plan Sheets\2024_PaveRehab_SWPPP.dwg February 29, 2024 - 6:56pm

No.	Date	Revisions	App.	DRAWING NAME
				2024_PaveRehab_SWPPP
				DESIGNED BY: ART
				DRAWN BY: ART
				CHECKED BY: ART
				DATE: 02/29/2024
				PROJECT NO. 24-01



11995 SINGLETREE LANE, SUITE 225, EDEN PRAIRIE, MN 55344
PHONE: 612-315-1272
WWW.KIMLEY-HORN.COM

I HEREBY CERTIFY THAT THIS PLAN, SPECIFICATION OR REPORT WAS PREPARED BY ME OR UNDER MY DIRECT SUPERVISION AND THAT I AM A DULY LICENSED PROFESSIONAL ENGINEER UNDER THE LAWS OF THE STATE OF MINNESOTA.

Adam R. Waden
ADAM R. WADEN
DATE: 02/29/2024 MN LIC. NO. 59337



CITY OF CHANHASSEN
2024 CITY PAVEMENT
REHABILITATION PROJECT

STORMWATER POLLUTION
PREVENTION PLAN

CITY PROJECT	24-01	SHEET NO.
		46
		188

K:\TOW_Civil\Civil\CHANHASSEN\2024 CITY STREET REHAB-RECONSTRUCT\CAD\Plan Sheets\2024_PaveRehab_REM.dwg February 29, 2024 - 6:56pm

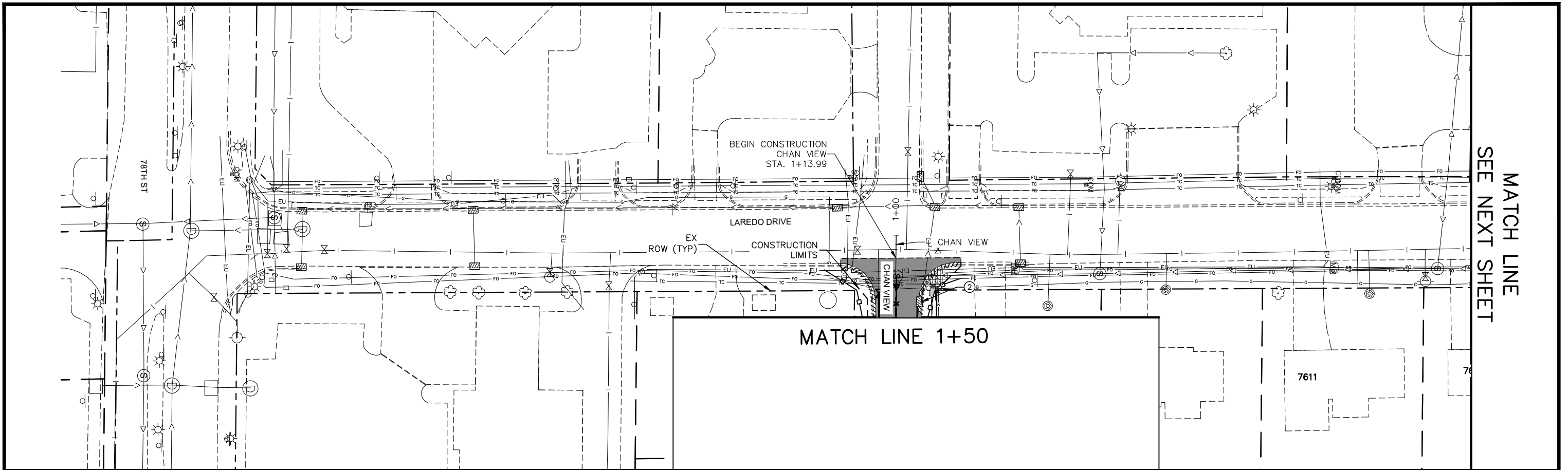

MATCH LINE
SEE NEXT SHEET

LEGEND:

- 2" BITUMINOUS MILL & OVERLAY
- FULL DEPTH RECLAMATION
- REMOVE FULL DEPTH
- REMOVE CONCRETE SIDEWALK
- REMOVE BITUMINOUS TRAIL
- REMOVE CONCRETE DRIVEWAY
- REMOVE BITUMINOUS DRIVEWAY
- REMOVE PAVER DRIVEWAY
- ROCK CONSTRUCTION ENTRANCE
- FULL DEPTH SAW CUT
- CONSTRUCTION LIMITS
- REMOVE CURB & GUTTER
- EXISTING RIGHT-OF-WAY
- REMOVE STORM SEWER PIPE
- REMOVE SANITARY SEWER PIPE
- REMOVE WATERMAIN PIPE
- CLEAR/GRUBB TREE
- PROTECT TREE
- STORM SEWER STRUCTURE PROTECTION
- SILT FENCE

SPECIFIC NOTES:

- ① REMOVE SANITARY SEWER MANHOLE
- ② REMOVE DRAINAGE STRUCTURE
- ③ ADJUST FRAME AND RINGS
- ④ REMOVE HYDRANT
- ⑤ REMOVE SIGN
- ⑥ EXISTING SPRINKLER SYSTEM – PROTECT IF POSSIBLE
- ⑦ EXISTING INVISIBLE PET FENCE – PROTECT IF POSSIBLE
- ⑧ SALVAGE SIGN
- ⑨ REMOVE GATE VALVE & BOX

REMOVAL NOTES:

- 1) STRIP, STOCKPILE AND REUSE INPLACE TOPSOIL IN AREAS TO BE DISTURBED BY CONSTRUCTION.
- 2) CONTRACTOR SHALL CALL GOPHER STATE ONE CALL AT 651-454-0002. ALL UTILITIES MUST BE LOCATED PRIOR TO THE START OF CONSTRUCTION.
- 3) SEE UTILITY PLANS AND DRAINAGE PLANS FOR UTILITY ADJUSTMENTS AND REPLACEMENTS
- 4) CONTRACTOR SHALL PROTECT ALL EXISTING UTILITY STRUCTURES THAT ARE NOT BEING REMOVED OR RELOCATED.
- 5) TRENCH BOXES OR OTHER TRENCH STABILIZATION METHODS MAY BE REQUIRED DURING CONSTRUCTION TO MINIMIZE REMOVAL LIMITS.
- 6) CONTRACTOR TO VERIFY REMOVAL LIMITS WITH ENGINEER PRIOR TO SAWCUTTING.
- 7) ENGINEER TO IDENTIFY AND MARK CONCRETE CURB AND GUTTER REMOVAL LOCATIONS.
- 8) ENGINEER TO IDENTIFY AND MARK CONCRETE AND BITUMINOUS DRIVEWAYS REMOVAL LOCATIONS.
- 9) ENGINEER TO IDENTIFY AND MARK CONCRETE WALK REMOVAL LOCATIONS.
- 10) COORDINATE WITH POSTAL PATRONS AND LOCAL POSTAL AUTHORITY TO RELOCATE MAILBOXES DURING CONSTRUCTION.
- 11) SEE UTILITY PLAN, SHEETS 68-87 FOR REPAIRS AND REPLACEMENT OF SANITARY SEWER AND WATERMAIN.
- 12) CONTRACTOR SHALL BE RESPONSIBLE FOR LOCATING, PROTECTING, SUPPORTING IRRIGATION AND SHALL TAKE ALL REASONABLE EFFORTS TO PROTECT IRRIGATION SYSTEMS WITHIN THE PROJECT AREA.
- 13) INVISIBLE DOG FENCES THAT ARE HIT SHALL BE TEMPORARILY RECONNECTED AS SOON AS POSSIBLE AFTER WORK IS COMPLETE IN THAT IMMEDIATE AREA, AND NO LONGER THAN 24 HRS. CONSTRUCTION MANAGER TO BE NOTIFIED WHEN A DOG FENCE HAS BEEN HIT (INCIDENTAL). CONTRACTOR MUST NOTIFY HOME OWNER IMMEDIATELY AFTER DOG FENCE IS HIT. (INCIDENTAL) DOG FENCE REPAIR WILL ONLY BE PAID ONCE PER ADDRESS.

EROSION CONTROL NOTES:

- 1) THE CONTRACTOR SHALL INSTALL AND MAINTAIN EROSION CONTROL FENCE AND SEDIMENT CONTROL LOG AS SHOWN AND AS DIRECTED BY ENGINEER IN FIELD. EROSION FENCE AND SEDIMENT CONTROL LOG TO BE REMOVED BY CONTRACTOR AFTER PERMANENT VEGETATION HAS BEEN ESTABLISHED.
 - 2) THE CONTRACTOR SHALL PLACE STORM SEWER STRUCTURE PROTECTION AT CATCH BASINS AS DIRECTED BY ENGINEER TO PREVENT SEDIMENT FROM ENTERING THE STORM SEWER DURING CONSTRUCTION.
 - 3) THE CONTRACTOR SHALL CONSTRUCT AND MAINTAIN ROCK ENTRANCES AT POINTS OF EXIT FROM PAVEMENT AS DIRECTED BY ENGINEER.
- FOR MORE EROSION CONTROL NOTES SEE GENERAL NOTES – SHEET 7

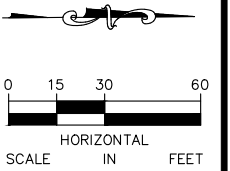

No.	Date	Revisions	App.	DRAWING NAME
				2024_PaveRehab_REM.dwg
				DESIGNED BY: MAK
				DRAWN BY: RCH
				CHECKED BY: MAK
				DATE: 02/29/2024
				PROJECT NO. 24-01

Kimley»Horn

11995 SINGLETREE LANE, SUITE 225, EDEN PRAIRIE, MN 55344
PHONE: 612-315-1272
WWW.KIMLEY-HORN.COM

I HEREBY CERTIFY THAT THIS PLAN, SPECIFICATION OR REPORT WAS PREPARED BY ME OR UNDER MY DIRECT SUPERVISION AND THAT I AM A DULY LICENSED PROFESSIONAL ENGINEER UNDER THE LAWS OF THE STATE OF MINNESOTA.

Michael A. Kirsch
MICHAEL A. KIRSCH
DATE: 02/29/2024 MN LIC. NO. 59057



CITY OF CHANHASSEN
2024 CITY PAVEMENT
REHABILITATION PROJECT

REMOVAL AND EROSION CONTROL PLANS
LAREDO DRIVE

CITY PROJECT 24-01 SHEET NO.

47

188

K:\TOW_Civil\City\CHANHASSEN\2024_CITY STREET REHAB-RECONSTRUCT\CAD\Plan Sheets\2024_PaveRehab_REM.dwg February 29, 2024 - 6:57pm

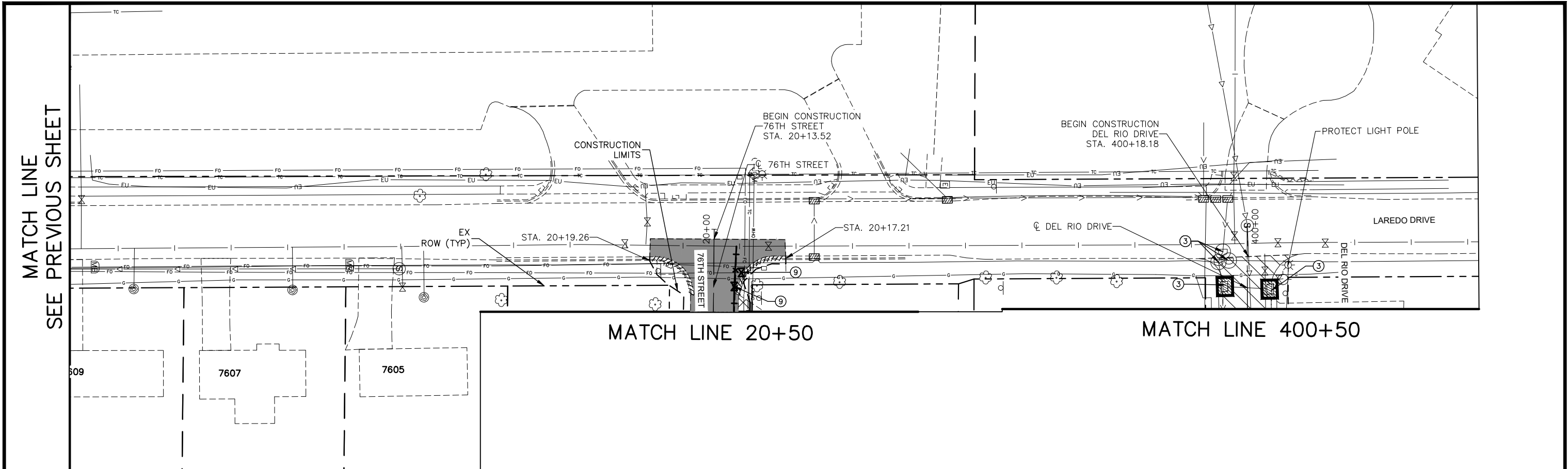

LEGEND:

- 2" BITUMINOUS MILL & OVERLAY
- FULL DEPTH RECLAMATION
- REMOVE FULL DEPTH
- REMOVE CONCRETE SIDEWALK
- REMOVE BITUMINOUS TRAIL
- REMOVE CONCRETE DRIVEWAY
- REMOVE BITUMINOUS DRIVEWAY
- REMOVE PAVER DRIVEWAY
- ROCK CONSTRUCTION ENTRANCE
- FULL DEPTH SAW CUT
- CONSTRUCTION LIMITS
- REMOVE CURB & GUTTER
- EXISTING RIGHT-OF-WAY
- REMOVE STORM SEWER PIPE
- REMOVE SANITARY SEWER PIPE
- REMOVE WATERMAIN PIPE
- CLEAR/GRUBB TREE
- PROTECT TREE
- STORM SEWER STRUCTURE PROTECTION
- SILT FENCE

SPECIFIC NOTES:

- ① REMOVE SANITARY SEWER MANHOLE
- ② REMOVE DRAINAGE STRUCTURE
- ③ ADJUST FRAME AND RINGS
- ④ REMOVE HYDRANT
- ⑤ REMOVE SIGN
- ⑥ EXISTING SPRINKLER SYSTEM – PROTECT IF POSSIBLE
- ⑦ EXISTING INVISIBLE PET FENCE – PROTECT IF POSSIBLE
- ⑧ SALVAGE SIGN
- ⑨ REMOVE GATE VALVE & BOX

REMOVAL NOTES:

- 1) STRIP, STOCKPILE AND REUSE INPLACE TOPSOIL IN AREAS TO BE DISTURBED BY CONSTRUCTION.
- 2) CONTRACTOR SHALL CALL GOPHER STATE ONE CALL AT 651-454-0002. ALL UTILITIES MUST BE LOCATED PRIOR TO THE START OF CONSTRUCTION.
- 3) SEE UTILITY PLANS AND DRAINAGE PLANS FOR UTILITY ADJUSTMENTS AND REPLACEMENTS
- 4) CONTRACTOR SHALL PROTECT ALL EXISTING UTILITY STRUCTURES THAT ARE NOT BEING REMOVED OR RELOCATED.
- 5) TRENCH BOXES OR OTHER TRENCH STABILIZATION METHODS MAY BE REQUIRED DURING CONSTRUCTION TO MINIMIZE REMOVAL LIMITS.
- 6) CONTRACTOR TO VERIFY REMOVAL LIMITS WITH ENGINEER PRIOR TO SAWCUTTING.
- 7) ENGINEER TO IDENTIFY AND MARK CONCRETE CURB AND GUTTER REMOVAL LOCATIONS.
- 8) ENGINEER TO IDENTIFY AND MARK CONCRETE AND BITUMINOUS DRIVEWAYS REMOVAL LOCATIONS.
- 9) ENGINEER TO IDENTIFY AND MARK CONCRETE WALK REMOVAL LOCATIONS.
- 10) COORDINATE WITH POSTAL PATRONS AND LOCAL POSTAL AUTHORITY TO RELOCATE MAILBOXES DURING CONSTRUCTION.
- 11) SEE UTILITY PLAN, SHEETS 68-87 FOR REPAIRS AND REPLACEMENT OF SANITARY SEWER AND WATERMAIN.
- 12) CONTRACTOR SHALL BE RESPONSIBLE FOR LOCATING, PROTECTING, SUPPORTING IRRIGATION AND SHALL TAKE ALL REASONABLE EFFORTS TO PROTECT IRRIGATION SYSTEMS WITHIN THE PROJECT AREA.
- 13) INVISIBLE DOG FENCES THAT ARE HIT SHALL BE TEMPORARILY RECONNECTED AS SOON AS POSSIBLE AFTER WORK IS COMPLETE IN THAT IMMEDIATE AREA, AND NO LONGER THAN 24 HRS. CONSTRUCTION MANAGER TO BE NOTIFIED WHEN A DOG FENCE HAS BEEN HIT (INCIDENTAL). CONTRACTOR MUST NOTIFY HOME OWNER IMMEDIATELY AFTER DOG FENCE IS HIT. (INCIDENTAL) DOG FENCE REPAIR WILL ONLY BE PAID ONCE PER ADDRESS.

EROSION CONTROL NOTES:

- 1) THE CONTRACTOR SHALL INSTALL AND MAINTAIN EROSION CONTROL FENCE AND SEDIMENT CONTROL LOG AS SHOWN AND AS DIRECTED BY ENGINEER IN FIELD. EROSION FENCE AND SEDIMENT CONTROL LOG TO BE REMOVED BY CONTRACTOR AFTER PERMANENT VEGETATION HAS BEEN ESTABLISHED.
 - 2) THE CONTRACTOR SHALL PLACE STORM SEWER STRUCTURE PROTECTION AT CATCH BASINS AS DIRECTED BY ENGINEER TO PREVENT SEDIMENT FROM ENTERING THE STORM SEWER DURING CONSTRUCTION.
 - 3) THE CONTRACTOR SHALL CONSTRUCT AND MAINTAIN ROCK ENTRANCES AT POINTS OF EXIT FROM PAVEMENT AS DIRECTED BY ENGINEER.
- FOR MORE EROSION CONTROL NOTES SEE GENERAL NOTES – SHEET 7

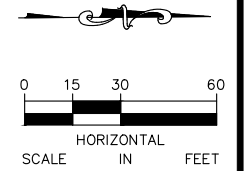

No.	Date	Revisions	App.	DRAWING NAME
				2024_PaveRehab_REM.dwg
				DESIGNED BY: MAK
				DRAWN BY: RCH
				CHECKED BY: MAK
				DATE: 02/29/2024
				PROJECT NO. 24-01

Kimley»Horn

11995 SINGLETREE LANE, SUITE 225, EDEN PRAIRIE, MN 55344
PHONE: 612-315-1272
WWW.KIMLEY-HORN.COM

I HEREBY CERTIFY THAT THIS PLAN, SPECIFICATION OR REPORT WAS PREPARED BY ME OR UNDER MY DIRECT SUPERVISION AND THAT I AM A DULY LICENSED PROFESSIONAL ENGINEER UNDER THE LAWS OF THE STATE OF MINNESOTA.

Michael A. Kirsch
MICHAEL A. KIRSCH
DATE: 02/29/2024 MN LIC. NO. 59057



CITY OF CHANHASSEN
2024 CITY PAVEMENT
REHABILITATION PROJECT

REMOVAL AND EROSION CONTROL PLANS
LAREDO DRIVE

CITY PROJECT	24-01	SHEET NO.	48	188
--------------	-------	-----------	----	-----

MATCH LINE SHEET 400+50

MATCH LINE 453+50

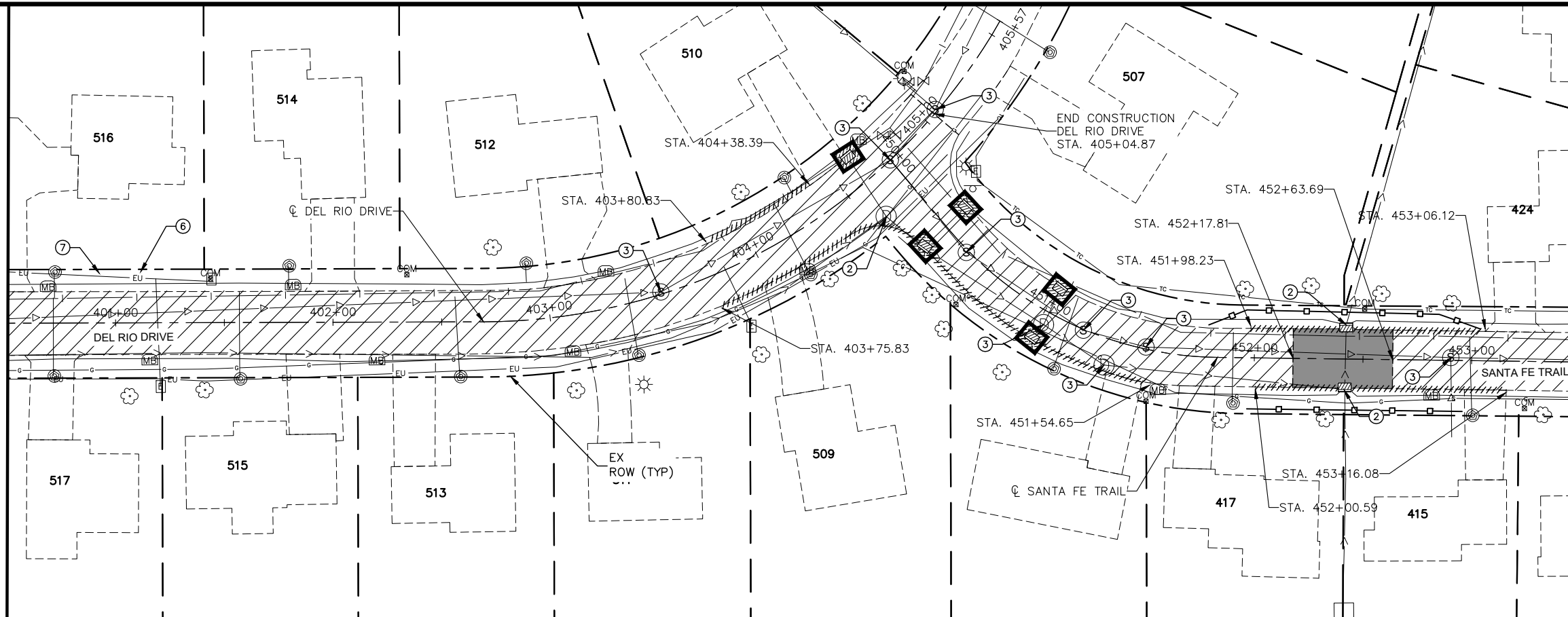

LEGEND:

- 2" BITUMINOUS MILL & OVERLAY
- FULL DEPTH RECLAMATION
- REMOVE FULL DEPTH
- REMOVE CONCRETE SIDEWALK
- REMOVE BITUMINOUS TRAIL
- REMOVE CONCRETE DRIVEWAY
- REMOVE BITUMINOUS DRIVEWAY
- REMOVE PAVER DRIVEWAY
- ROCK CONSTRUCTION ENTRANCE
- FULL DEPTH SAW CUT
- CONSTRUCTION LIMITS
- REMOVE CURB & GUTTER
- EXISTING RIGHT-OF-WAY
- REMOVE STORM SEWER PIPE
- REMOVE SANITARY SEWER PIPE
- REMOVE WATERMAIN PIPE
- CLEAR/GRUBB TREE
- PROTECT TREE
- STORM SEWER STRUCTURE PROTECTION
- SILT FENCE

SPECIFIC NOTES:

- ① REMOVE SANITARY SEWER MANHOLE
- ② REMOVE DRAINAGE STRUCTURE
- ③ ADJUST FRAME AND RINGS
- ④ REMOVE HYDRANT
- ⑤ REMOVE SIGN
- ⑥ EXISTING SPRINKLER SYSTEM – PROTECT IF POSSIBLE
- ⑦ EXISTING INVISIBLE PET FENCE – PROTECT IF POSSIBLE
- ⑧ SALVAGE SIGN
- ⑨ REMOVE GATE VALVE & BOX

REMOVAL NOTES:

- 1) STRIP, STOCKPILE AND REUSE INPLACE TOPSOIL IN AREAS TO BE DISTURBED BY CONSTRUCTION.
- 2) CONTRACTOR SHALL CALL GOPHER STATE ONE CALL AT 651-454-0002. ALL UTILITIES MUST BE LOCATED PRIOR TO THE START OF CONSTRUCTION.
- 3) SEE UTILITY PLANS AND DRAINAGE PLANS FOR UTILITY ADJUSTMENTS AND REPLACEMENTS
- 4) CONTRACTOR SHALL PROTECT ALL EXISTING UTILITY STRUCTURES THAT ARE NOT BEING REMOVED OR RELOCATED.
- 5) TRENCH BOXES OR OTHER TRENCH STABILIZATION METHODS MAY BE REQUIRED DURING CONSTRUCTION TO MINIMIZE REMOVAL LIMITS.
- 6) CONTRACTOR TO VERIFY REMOVAL LIMITS WITH ENGINEER PRIOR TO SAWCUTTING.
- 7) ENGINEER TO IDENTIFY AND MARK CONCRETE CURB AND GUTTER REMOVAL LOCATIONS.
- 8) ENGINEER TO IDENTIFY AND MARK CONCRETE AND BITUMINOUS DRIVEWAYS REMOVAL LOCATIONS.
- 9) ENGINEER TO IDENTIFY AND MARK CONCRETE WALK REMOVAL LOCATIONS.
- 10) COORDINATE WITH POSTAL PATRONS AND LOCAL POSTAL AUTHORITY TO RELOCATE MAILBOXES DURING CONSTRUCTION.
- 11) SEE UTILITY PLAN, SHEETS 68-87 FOR REPAIRS AND REPLACEMENT OF SANITARY SEWER AND WATERMAIN.
- 12) CONTRACTOR SHALL BE RESPONSIBLE FOR LOCATING, PROTECTING, SUPPORTING IRRIGATION AND SHALL TAKE ALL REASONABLE EFFORTS TO PROTECT IRRIGATION SYSTEMS WITHIN THE PROJECT AREA.
- 13) INVISIBLE DOG FENCES THAT ARE HIT SHALL BE TEMPORARILY RECONNECTED AS SOON AS POSSIBLE AFTER WORK IS COMPLETE IN THAT IMMEDIATE AREA, AND NO LONGER THAN 24 HRS. CONSTRUCTION MANAGER TO BE NOTIFIED WHEN A DOG FENCE HAS BEEN HIT (INCIDENTAL). CONTRACTOR MUST NOTIFY HOME OWNER IMMEDIATELY AFTER DOG FENCE IS HIT. (INCIDENTAL) DOG FENCE REPAIR WILL ONLY BE PAID ONCE PER ADDRESS.

EROSION CONTROL NOTES:

- 1) THE CONTRACTOR SHALL INSTALL AND MAINTAIN EROSION CONTROL FENCE AND SEDIMENT CONTROL LOG AS SHOWN AND AS DIRECTED BY ENGINEER IN FIELD. EROSION FENCE AND SEDIMENT CONTROL LOG TO BE REMOVED BY CONTRACTOR AFTER PERMANENT VEGETATION HAS BEEN ESTABLISHED.
 - 2) THE CONTRACTOR SHALL PLACE STORM SEWER STRUCTURE PROTECTION AT CATCH BASINS AS DIRECTED BY ENGINEER TO PREVENT SEDIMENT FROM ENTERING THE STORM SEWER DURING CONSTRUCTION.
 - 3) THE CONTRACTOR SHALL CONSTRUCT AND MAINTAIN ROCK ENTRANCES AT POINTS OF EXIT FROM PAVEMENT AS DIRECTED BY ENGINEER.
- FOR MORE EROSION CONTROL NOTES SEE GENERAL NOTES – SHEET 7

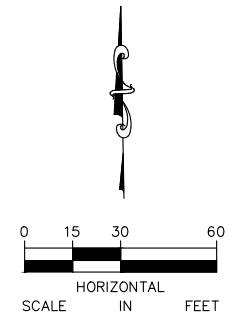

No.	Date	Revisions	App.	DRAWING NAME
				2024_PaveRehab_REM.dwg
				DESIGNED BY: MAK
				DRAWN BY: RCH
				CHECKED BY: MAK
				DATE: 02/29/2024
				PROJECT NO. 24-01

Kimley»Horn

11995 SINGLETREE LANE, SUITE 225, EDEN PRAIRIE, MN 55344
 PHONE: 612-315-1272
 WWW.KIMLEY-HORN.COM

I HEREBY CERTIFY THAT THIS PLAN, SPECIFICATION OR REPORT WAS PREPARED BY ME OR UNDER MY DIRECT SUPERVISION AND THAT I AM A DULY LICENSED PROFESSIONAL ENGINEER UNDER THE LAWS OF THE STATE OF MINNESOTA.

Michael Kirsch
 MICHAEL A. KIRSCH
 DATE: 02/29/2024 MN LIC. NO. 59057



CITY OF CHANHASSEN
 2024 CITY PAVEMENT
 REHABILITATION PROJECT

REMOVAL AND EROSION CONTROL PLANS
 DEL RIO DR AND SANTA FE TRAIL
 STA. 400+50 TO STA. 543+50

CITY PROJECT	24-01	SHEET NO.
		49
		188

K:\TOW_Civil\City\CHANHASSEN\2024_CITY STREET REHAB-RECONSTRUCT\CAD\Plan Sheets\2024_PaveRehab_REM.dwg February 29, 2024 - 6:57pm

K:\TOW_Civil\City\CHANHASSEN\2024_CITY STREET REHAB-RECONSTRUCT\CAD\Plan Sheets\2024_PaveRehab_REM.dwg February 29, 2024 - 6:57pm

MATCH LINE 543+50

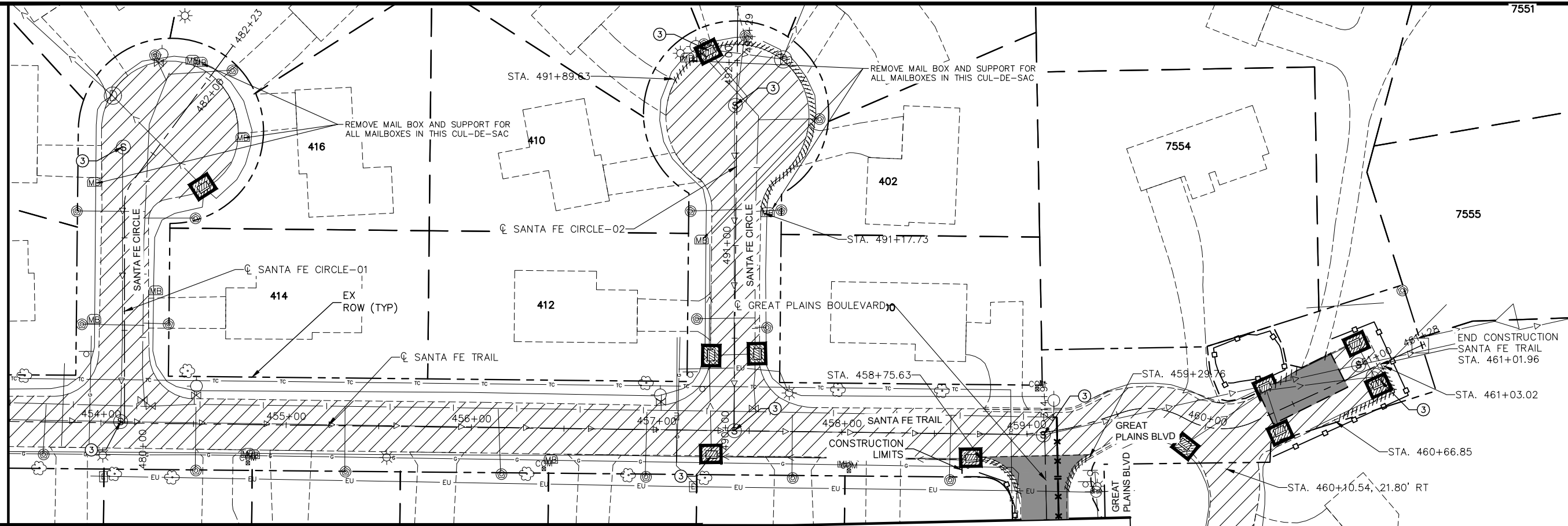

MATCH LINE SHEET 314+50

LEGEND:

- 2" BITUMINOUS MILL & OVERLAY
- FULL DEPTH RECLAMATION
- REMOVE FULL DEPTH
- REMOVE CONCRETE SIDEWALK
- REMOVE BITUMINOUS TRAIL
- REMOVE CONCRETE DRIVEWAY
- REMOVE BITUMINOUS DRIVEWAY
- REMOVE PAVER DRIVEWAY
- ROCK CONSTRUCTION ENTRANCE
- FULL DEPTH SAW CUT
- CONSTRUCTION LIMITS
- REMOVE CURB & GUTTER
- EXISTING RIGHT-OF-WAY
- REMOVE STORM SEWER PIPE
- REMOVE SANITARY SEWER PIPE
- REMOVE WATERMAIN PIPE
- CLEAR/GRUBB TREE
- PROTECT TREE
- STORM SEWER STRUCTURE PROTECTION
- SILT FENCE

REMOVAL NOTES:

- 1) STRIP, STOCKPILE AND REUSE INPLACE TOPSOIL IN AREAS TO BE DISTURBED BY CONSTRUCTION.
- 2) CONTRACTOR SHALL CALL GOPHER STATE ONE CALL AT 651-454-0002. ALL UTILITIES MUST BE LOCATED PRIOR TO THE START OF CONSTRUCTION.
- 3) SEE UTILITY PLANS AND DRAINAGE PLANS FOR UTILITY ADJUSTMENTS AND REPLACEMENTS
- 4) CONTRACTOR SHALL PROTECT ALL EXISTING UTILITY STRUCTURES THAT ARE NOT BEING REMOVED OR RELOCATED.
- 5) TRENCH BOXES OR OTHER TRENCH STABILIZATION METHODS MAY BE REQUIRED DURING CONSTRUCTION TO MINIMIZE REMOVAL LIMITS.
- 6) CONTRACTOR TO VERIFY REMOVAL LIMITS WITH ENGINEER PRIOR TO SAWCUTTING.
- 7) ENGINEER TO IDENTIFY AND MARK CONCRETE CURB AND GUTTER REMOVAL LOCATIONS.
- 8) ENGINEER TO IDENTIFY AND MARK CONCRETE AND BITUMINOUS DRIVEWAYS REMOVAL LOCATIONS.
- 9) ENGINEER TO IDENTIFY AND MARK CONCRETE WALK REMOVAL LOCATIONS.
- 10) COORDINATE WITH POSTAL PATRONS AND LOCAL POSTAL AUTHORITY TO RELOCATE MAILBOXES DURING CONSTRUCTION.
- 11) SEE UTILITY PLAN, SHEETS 68-87 FOR REPAIRS AND REPLACEMENT OF SANITARY SEWER AND WATERMAIN.
- 12) CONTRACTOR SHALL BE RESPONSIBLE FOR LOCATING, PROTECTING, SUPPORTING IRRIGATION AND SHALL TAKE ALL REASONABLE EFFORTS TO PROTECT IRRIGATION SYSTEMS WITHIN THE PROJECT AREA.

INVISIBLE DOG FENCES THAT ARE HIT SHALL BE TEMPORARILY RECONNECTED AS SOON AS POSSIBLE AFTER WORK IS COMPLETE IN THAT IMMEDIATE AREA, AND NO LONGER THAN 24 HRS. CONSTRUCTION MANAGER TO BE NOTIFIED WHEN A DOG FENCE HAS BEEN HIT (INCIDENTAL). CONTRACTOR MUST NOTIFY HOME OWNER IMMEDIATELY AFTER DOG FENCE IS HIT. (INCIDENTAL) DOG FENCE REPAIR WILL ONLY BE PAID ONCE PER ADDRESS.
- 13)

SPECIFIC NOTES:

- ① REMOVE SANITARY SEWER MANHOLE
- ② REMOVE DRAINAGE STRUCTURE
- ③ ADJUST FRAME AND RINGS
- ④ REMOVE HYDRANT
- ⑤ REMOVE SIGN
- ⑥ EXISTING SPRINKLER SYSTEM - PROTECT IF POSSIBLE
- ⑦ EXISTING INVISIBLE PET FENCE - PROTECT IF POSSIBLE
- ⑧ SALVAGE SIGN
- ⑨ REMOVE GATE VALVE & BOX

EROSION CONTROL NOTES:

- 1) THE CONTRACTOR SHALL INSTALL AND MAINTAIN EROSION CONTROL FENCE AND SEDIMENT CONTROL LOG AS SHOWN AND AS DIRECTED BY ENGINEER IN FIELD. EROSION FENCE AND SEDIMENT CONTROL LOG TO BE REMOVED BY CONTRACTOR AFTER PERMANENT VEGETATION HAS BEEN ESTABLISHED.
 - 2) THE CONTRACTOR SHALL PLACE STORM SEWER STRUCTURE PROTECTION AT CATCH BASINS AS DIRECTED BY ENGINEER TO PREVENT SEDIMENT FROM ENTERING THE STORM SEWER DURING CONSTRUCTION.
 - 3) THE CONTRACTOR SHALL CONSTRUCT AND MAINTAIN ROCK ENTRANCES AT POINTS OF EXIT FROM PAVEMENT AS DIRECTED BY ENGINEER.
- FOR MORE EROSION CONTROL NOTES SEE GENERAL NOTES - SHEET 7

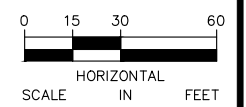

No.	Date	Revisions	App.	DRAWING NAME
				2024_PaveRehab_REM.dwg
				DESIGNED BY: MAK
				DRAWN BY: RCH
				CHECKED BY: MAK
				DATE: 02/29/2024
				PROJECT NO. 24-01

Kimley»Horn

11995 SINGLETREE LANE, SUITE 225, EDEN PRAIRIE, MN 55344
 PHONE: 612-315-1272
 WWW.KIMLEY-HORN.COM

I HEREBY CERTIFY THAT THIS PLAN, SPECIFICATION OR REPORT WAS PREPARED BY ME OR UNDER MY DIRECT SUPERVISION AND THAT I AM A DULY LICENSED PROFESSIONAL ENGINEER UNDER THE LAWS OF THE STATE OF MINNESOTA.

Michael A. Kirsch
 MICHAEL A. KIRSCH
 DATE: 02/29/2024 MN LIC. NO. 59057



CITY OF CHANHASSEN
 2024 CITY PAVEMENT REHABILITATION PROJECT

REMOVAL AND EROSION CONTROL PLANS
 DEL RIO DR AND SANTA FE TRAIL
 STA. 543+50 TO STA. 459+14

CITY PROJECT 24-01

SHEET NO. 50

188

K:\TOW_Civil\City\CHANHASSEN\2024\CITY STREET REHAB-RECONSTRUCT\CAD\Plan Sheets\2024_PaveRehab_REM.dwg February 29, 2024 - 6:57pm

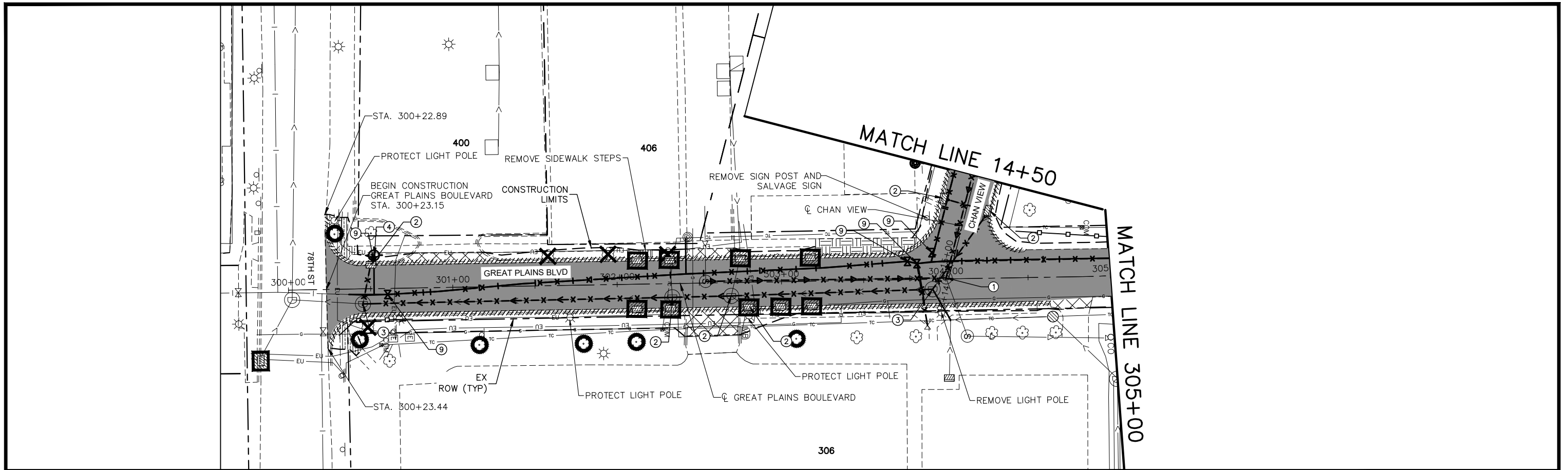

LEGEND:

- 2" BITUMINOUS MILL & OVERLAY
- FULL DEPTH RECLAMATION
- REMOVE FULL DEPTH
- REMOVE CONCRETE SIDEWALK
- REMOVE BITUMINOUS TRAIL
- REMOVE CONCRETE DRIVEWAY
- REMOVE BITUMINOUS DRIVEWAY
- REMOVE PAVER DRIVEWAY
- ROCK CONSTRUCTION ENTRANCE
- FULL DEPTH SAW CUT
- CONSTRUCTION LIMITS
- REMOVE CURB & GUTTER
- EXISTING RIGHT-OF-WAY
- REMOVE STORM SEWER PIPE
- REMOVE SANITARY SEWER PIPE
- REMOVE WATERMAIN PIPE
- CLEAR/GRUBB TREE
- PROTECT TREE
- STORM SEWER STRUCTURE PROTECTION
- SILT FENCE

SPECIFIC NOTES:

- ① REMOVE SANITARY SEWER MANHOLE
- ② REMOVE DRAINAGE STRUCTURE
- ③ ADJUST FRAME AND RINGS
- ④ REMOVE HYDRANT
- ⑤ REMOVE SIGN
- ⑥ EXISTING SPRINKLER SYSTEM – PROTECT IF POSSIBLE
- ⑦ EXISTING INVISIBLE PET FENCE – PROTECT IF POSSIBLE
- ⑧ SALVAGE SIGN
- ⑨ REMOVE GATE VALVE & BOX

REMOVAL NOTES:

- 1) STRIP, STOCKPILE AND REUSE INPLACE TOPSOIL IN AREAS TO BE DISTURBED BY CONSTRUCTION.
- 2) CONTRACTOR SHALL CALL GOPHER STATE ONE CALL AT 651-454-0002. ALL UTILITIES MUST BE LOCATED PRIOR TO THE START OF CONSTRUCTION.
- 3) SEE UTILITY PLANS AND DRAINAGE PLANS FOR UTILITY ADJUSTMENTS AND REPLACEMENTS
- 4) CONTRACTOR SHALL PROTECT ALL EXISTING UTILITY STRUCTURES THAT ARE NOT BEING REMOVED OR RELOCATED.
- 5) TRENCH BOXES OR OTHER TRENCH STABILIZATION METHODS MAY BE REQUIRED DURING CONSTRUCTION TO MINIMIZE REMOVAL LIMITS.
- 6) CONTRACTOR TO VERIFY REMOVAL LIMITS WITH ENGINEER PRIOR TO SAWCUTTING.
- 7) ENGINEER TO IDENTIFY AND MARK CONCRETE CURB AND GUTTER REMOVAL LOCATIONS.
- 8) ENGINEER TO IDENTIFY AND MARK CONCRETE AND BITUMINOUS DRIVEWAYS REMOVAL LOCATIONS.
- 9) ENGINEER TO IDENTIFY AND MARK CONCRETE WALK REMOVAL LOCATIONS.
- 10) COORDINATE WITH POSTAL PATRONS AND LOCAL POSTAL AUTHORITY TO RELOCATE MAILBOXES DURING CONSTRUCTION.
- 11) SEE UTILITY PLAN, SHEETS 68-87 FOR REPAIRS AND REPLACEMENT OF SANITARY SEWER AND WATERMAIN.
- 12) CONTRACTOR SHALL BE RESPONSIBLE FOR LOCATING, PROTECTING, SUPPORTING IRRIGATION AND SHALL TAKE ALL REASONABLE EFFORTS TO PROTECT IRRIGATION SYSTEMS WITHIN THE PROJECT AREA.
- 13) INVISIBLE DOG FENCES THAT ARE HIT SHALL BE TEMPORARILY RECONNECTED AS SOON AS POSSIBLE AFTER WORK IS COMPLETE IN THAT IMMEDIATE AREA, AND NO LONGER THAN 24 HRS. CONSTRUCTION MANAGER TO BE NOTIFIED WHEN A DOG FENCE HAS BEEN HIT (INCIDENTAL). CONTRACTOR MUST NOTIFY HOME OWNER IMMEDIATELY AFTER DOG FENCE IS HIT. (INCIDENTAL) DOG FENCE REPAIR WILL ONLY BE PAID ONCE PER ADDRESS.

EROSION CONTROL NOTES:

- 1) THE CONTRACTOR SHALL INSTALL AND MAINTAIN EROSION CONTROL FENCE AND SEDIMENT CONTROL LOG AS SHOWN AND AS DIRECTED BY ENGINEER IN FIELD. EROSION FENCE AND SEDIMENT CONTROL LOG TO BE REMOVED BY CONTRACTOR AFTER PERMANENT VEGETATION HAS BEEN ESTABLISHED.
 - 2) THE CONTRACTOR SHALL PLACE STORM SEWER STRUCTURE PROTECTION AT CATCH BASINS AS DIRECTED BY ENGINEER TO PREVENT SEDIMENT FROM ENTERING THE STORM SEWER DURING CONSTRUCTION.
 - 3) THE CONTRACTOR SHALL CONSTRUCT AND MAINTAIN ROCK ENTRANCES AT POINTS OF EXIT FROM PAVEMENT AS DIRECTED BY ENGINEER.
- FOR MORE EROSION CONTROL NOTES SEE GENERAL NOTES – SHEET 7

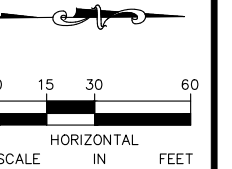

No.	Date	Revisions	App.	DRAWING NAME
				2024_PaveRehab_REM.dwg
				DESIGNED BY: MAK
				DRAWN BY: RCH
				CHECKED BY: MAK
				DATE: 02/29/2024
				PROJECT NO. 24-01

Kimley»Horn

11995 SINGLETREE LANE, SUITE 225, EDEN PRAIRIE, MN 55344
 PHONE: 612-315-1272
 WWW.KIMLEY-HORN.COM

I HEREBY CERTIFY THAT THIS PLAN, SPECIFICATION OR REPORT WAS PREPARED BY ME OR UNDER MY DIRECT SUPERVISION AND THAT I AM A DULY LICENSED PROFESSIONAL ENGINEER UNDER THE LAWS OF THE STATE OF MINNESOTA.

Michael A. Kirsch
 MICHAEL A. KIRSCH
 DATE: 02/29/2024 MN LIC. NO. 59057



CITY OF CHANHASSEN
 2024 CITY PAVEMENT
 REHABILITATION PROJECT

REMOVAL AND EROSION CONTROL PLANS
 GREAT PLAINS BOULEVARD
 STA. 300+00 TO STA. 305+00

CITY PROJECT 24-01 SHEET NO.

51

188

K:\TOW_Civil\CHANHASSEN\2024_CITY STREET REHAB-RECONSTRUCT\CAD\Plan Sheets\2024_PaveRehab_REM.dwg February 29, 2024 - 6:57pm

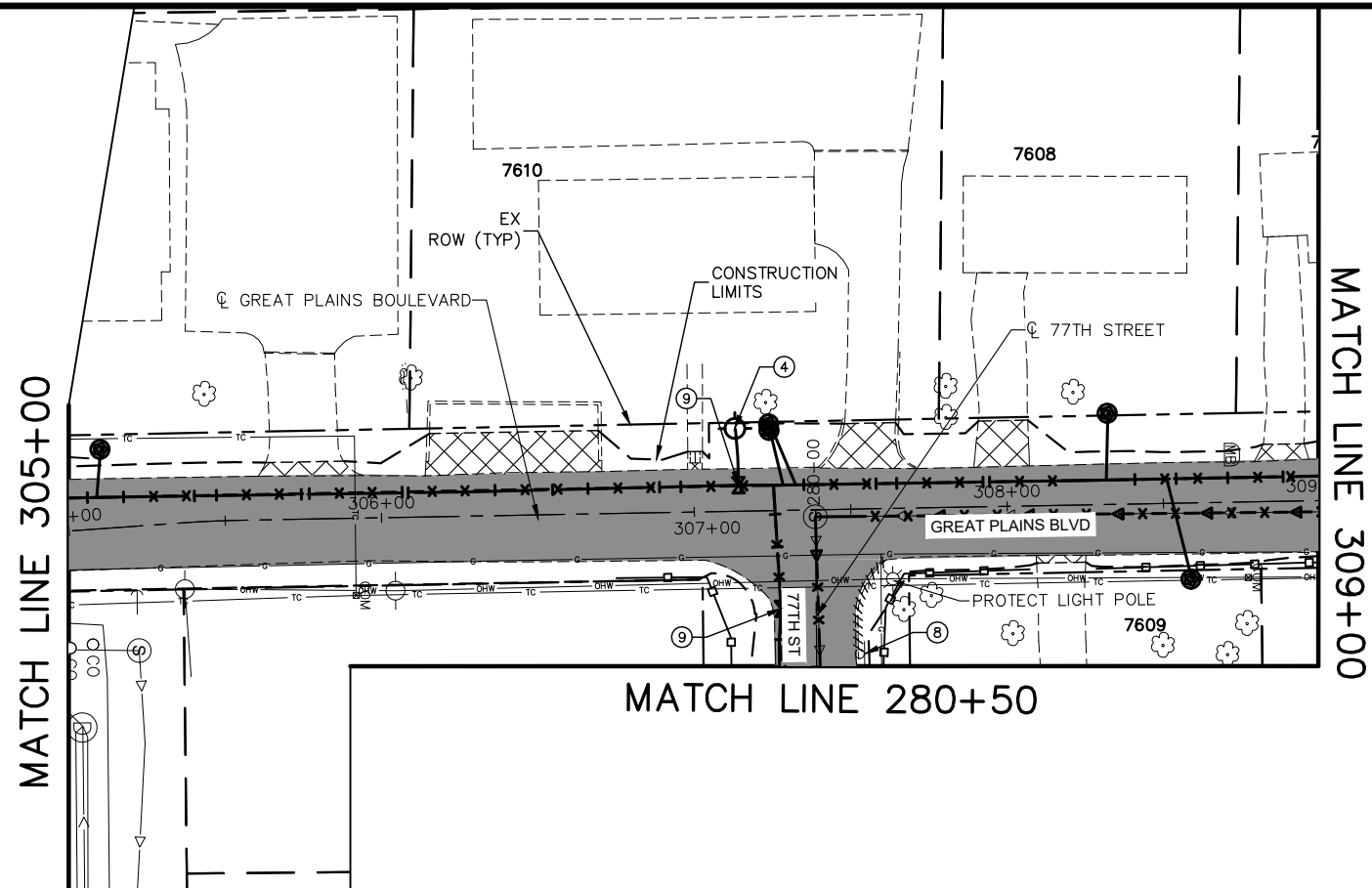

LEGEND:

- 2" BITUMINOUS MILL & OVERLAY
- FULL DEPTH RECLAMATION
- REMOVE FULL DEPTH
- REMOVE CONCRETE SIDEWALK
- REMOVE BITUMINOUS TRAIL
- REMOVE CONCRETE DRIVEWAY
- REMOVE BITUMINOUS DRIVEWAY
- REMOVE PAVER DRIVEWAY
- ROCK CONSTRUCTION ENTRANCE
- FULL DEPTH SAW CUT
- CONSTRUCTION LIMITS
- REMOVE CURB & GUTTER
- EXISTING RIGHT-OF-WAY
- REMOVE STORM SEWER PIPE
- REMOVE SANITARY SEWER PIPE
- REMOVE WATERMAIN PIPE
- CLEAR/GRUBB TREE
- PROTECT TREE
- STORM SEWER STRUCTURE PROTECTION
- SILT FENCE

SPECIFIC NOTES:

- ① REMOVE SANITARY SEWER MANHOLE
- ② REMOVE DRAINAGE STRUCTURE
- ③ ADJUST FRAME AND RINGS
- ④ REMOVE HYDRANT
- ⑤ REMOVE SIGN
- ⑥ EXISTING SPRINKLER SYSTEM – PROTECT IF POSSIBLE
- ⑦ EXISTING INVISIBLE PET FENCE – PROTECT IF POSSIBLE
- ⑧ SALVAGE SIGN
- ⑨ REMOVE GATE VALVE & BOX

REMOVAL NOTES:

- 1) STRIP, STOCKPILE AND REUSE INPLACE TOPSOIL IN AREAS TO BE DISTURBED BY CONSTRUCTION.
- 2) CONTRACTOR SHALL CALL GOPHER STATE ONE CALL AT 651-454-0002. ALL UTILITIES MUST BE LOCATED PRIOR TO THE START OF CONSTRUCTION.
- 3) SEE UTILITY PLANS AND DRAINAGE PLANS FOR UTILITY ADJUSTMENTS AND REPLACEMENTS
- 4) CONTRACTOR SHALL PROTECT ALL EXISTING UTILITY STRUCTURES THAT ARE NOT BEING REMOVED OR RELOCATED.
- 5) TRENCH BOXES OR OTHER TRENCH STABILIZATION METHODS MAY BE REQUIRED DURING CONSTRUCTION TO MINIMIZE REMOVAL LIMITS.
- 6) CONTRACTOR TO VERIFY REMOVAL LIMITS WITH ENGINEER PRIOR TO SAWCUTTING.
- 7) ENGINEER TO IDENTIFY AND MARK CONCRETE CURB AND GUTTER REMOVAL LOCATIONS.
- 8) ENGINEER TO IDENTIFY AND MARK CONCRETE AND BITUMINOUS DRIVEWAYS REMOVAL LOCATIONS.
- 9) ENGINEER TO IDENTIFY AND MARK CONCRETE WALK REMOVAL LOCATIONS.
- 10) COORDINATE WITH POSTAL PATRONS AND LOCAL POSTAL AUTHORITY TO RELOCATE MAILBOXES DURING CONSTRUCTION.
- 11) SEE UTILITY PLAN, SHEETS 68-87 FOR REPAIRS AND REPLACEMENT OF SANITARY SEWER AND WATERMAIN.
- 12) CONTRACTOR SHALL BE RESPONSIBLE FOR LOCATING, PROTECTING, SUPPORTING IRRIGATION AND SHALL TAKE ALL REASONABLE EFFORTS TO PROTECT IRRIGATION SYSTEMS WITHIN THE PROJECT AREA.
- 13) INVISIBLE DOG FENCES THAT ARE HIT SHALL BE TEMPORARILY RECONNECTED AS SOON AS POSSIBLE AFTER WORK IS COMPLETE IN THAT IMMEDIATE AREA, AND NO LONGER THAN 24 HRS. CONSTRUCTION MANAGER TO BE NOTIFIED WHEN A DOG FENCE HAS BEEN HIT (INCIDENTAL). CONTRACTOR MUST NOTIFY HOME OWNER IMMEDIATELY AFTER DOG FENCE IS HIT. (INCIDENTAL) DOG FENCE REPAIR WILL ONLY BE PAID ONCE PER ADDRESS.

EROSION CONTROL NOTES:

- 1) THE CONTRACTOR SHALL INSTALL AND MAINTAIN EROSION CONTROL FENCE AND SEDIMENT CONTROL LOG AS SHOWN AND AS DIRECTED BY ENGINEER IN FIELD. EROSION FENCE AND SEDIMENT CONTROL LOG TO BE REMOVED BY CONTRACTOR AFTER PERMANENT VEGETATION HAS BEEN ESTABLISHED.
 - 2) THE CONTRACTOR SHALL PLACE STORM SEWER STRUCTURE PROTECTION AT CATCH BASINS AS DIRECTED BY ENGINEER TO PREVENT SEDIMENT FROM ENTERING THE STORM SEWER DURING CONSTRUCTION.
 - 3) THE CONTRACTOR SHALL CONSTRUCT AND MAINTAIN ROCK ENTRANCES AT POINTS OF EXIT FROM PAVEMENT AS DIRECTED BY ENGINEER.
- FOR MORE EROSION CONTROL NOTES SEE GENERAL NOTES – SHEET 7

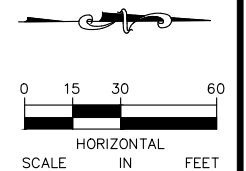

No.	Date	Revisions	App.	DRAWING NAME
				2024_PaveRehab_REM.dwg
				DESIGNED BY: MAK
				DRAWN BY: RCH
				CHECKED BY: MAK
				DATE: 02/29/2024
				PROJECT NO. 24-01

Kimley»Horn
 11995 SINGLETREE LANE, SUITE 225, EDEN PRAIRIE, MN 55344
 PHONE: 612-315-1272
 WWW.KIMLEY-HORN.COM

I HEREBY CERTIFY THAT THIS PLAN, SPECIFICATION OR REPORT WAS PREPARED BY ME OR UNDER MY DIRECT SUPERVISION AND THAT I AM A DULY LICENSED PROFESSIONAL ENGINEER UNDER THE LAWS OF THE STATE OF MINNESOTA.

Michael A. Kirsch
 MICHAEL A. KIRSCH
 DATE: 02/29/2024 MN LIC. NO. 59057



CITY OF CHANHASSEN
 2024 CITY PAVEMENT
 REHABILITATION PROJECT

REMOVAL AND EROSION CONTROL PLANS
 GREAT PLAINS BOULEVARD
 STA. 305+00 TO STA. 309+00

CITY PROJECT	24-01	SHEET NO.
		52
		188

K:\TOW_Civil\City\CHANHASSEN\2024_CITY STREET REHAB-RECONSTRUCT\CAD\Plan Sheets\2024_PaveRehab_REM.dwg February 29, 2024 - 6:57pm

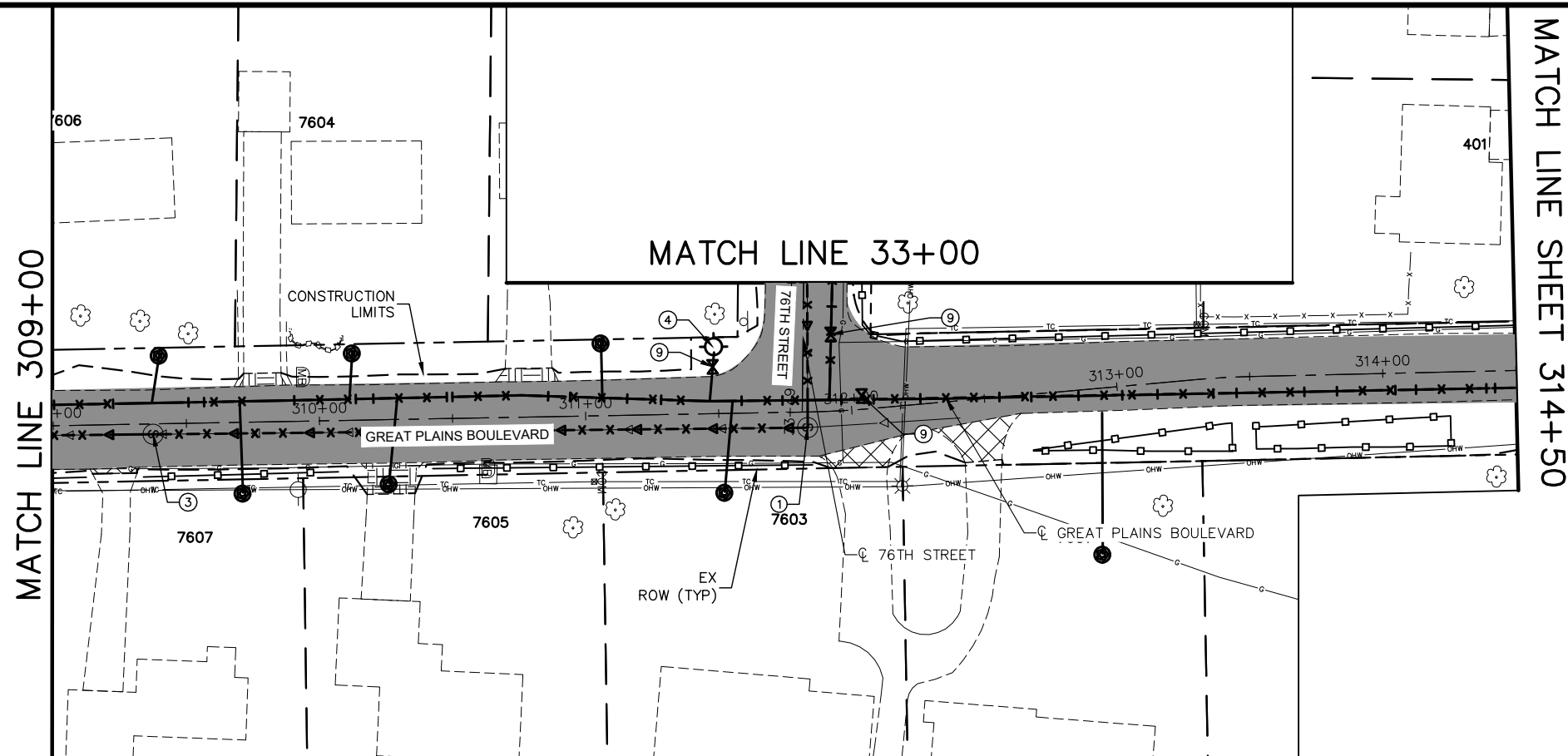

LEGEND:

- 2" BITUMINOUS MILL & OVERLAY
- FULL DEPTH RECLAMATION
- REMOVE FULL DEPTH
- REMOVE CONCRETE SIDEWALK
- REMOVE BITUMINOUS TRAIL
- REMOVE CONCRETE DRIVEWAY
- REMOVE BITUMINOUS DRIVEWAY
- REMOVE PAVER DRIVEWAY
- ROCK CONSTRUCTION ENTRANCE
- FULL DEPTH SAW CUT
- CONSTRUCTION LIMITS
- REMOVE CURB & GUTTER
- EXISTING RIGHT-OF-WAY
- REMOVE STORM SEWER PIPE
- REMOVE SANITARY SEWER PIPE
- REMOVE WATERMAIN PIPE
- CLEAR/GRUBB TREE
- PROTECT TREE
- STORM SEWER STRUCTURE PROTECTION
- SILT FENCE

SPECIFIC NOTES:

- ① REMOVE SANITARY SEWER MANHOLE
- ② REMOVE DRAINAGE STRUCTURE
- ③ ADJUST FRAME AND RINGS
- ④ REMOVE HYDRANT
- ⑤ REMOVE SIGN
- ⑥ EXISTING SPRINKLER SYSTEM – PROTECT IF POSSIBLE
- ⑦ EXISTING INVISIBLE PET FENCE – PROTECT IF POSSIBLE
- ⑧ SALVAGE SIGN
- ⑨ REMOVE GATE VALVE & BOX

REMOVAL NOTES:

- 1) STRIP, STOCKPILE AND REUSE INPLACE TOPSOIL IN AREAS TO BE DISTURBED BY CONSTRUCTION.
- 2) CONTRACTOR SHALL CALL GOPHER STATE ONE CALL AT 651-454-0002. ALL UTILITIES MUST BE LOCATED PRIOR TO THE START OF CONSTRUCTION.
- 3) SEE UTILITY PLANS AND DRAINAGE PLANS FOR UTILITY ADJUSTMENTS AND REPLACEMENTS
- 4) CONTRACTOR SHALL PROTECT ALL EXISTING UTILITY STRUCTURES THAT ARE NOT BEING REMOVED OR RELOCATED.
- 5) TRENCH BOXES OR OTHER TRENCH STABILIZATION METHODS MAY BE REQUIRED DURING CONSTRUCTION TO MINIMIZE REMOVAL LIMITS.
- 6) CONTRACTOR TO VERIFY REMOVAL LIMITS WITH ENGINEER PRIOR TO SAWCUTTING.
- 7) ENGINEER TO IDENTIFY AND MARK CONCRETE CURB AND GUTTER REMOVAL LOCATIONS.
- 8) ENGINEER TO IDENTIFY AND MARK CONCRETE AND BITUMINOUS DRIVEWAYS REMOVAL LOCATIONS.
- 9) ENGINEER TO IDENTIFY AND MARK CONCRETE WALK REMOVAL LOCATIONS.
- 10) COORDINATE WITH POSTAL PATRONS AND LOCAL POSTAL AUTHORITY TO RELOCATE MAILBOXES DURING CONSTRUCTION.
- 11) SEE UTILITY PLAN, SHEETS 68-87 FOR REPAIRS AND REPLACEMENT OF SANITARY SEWER AND WATERMAIN.
- 12) CONTRACTOR SHALL BE RESPONSIBLE FOR LOCATING, PROTECTING, SUPPORTING IRRIGATION AND SHALL TAKE ALL REASONABLE EFFORTS TO PROTECT IRRIGATION SYSTEMS WITHIN THE PROJECT AREA.
- 13) INVISIBLE DOG FENCES THAT ARE HIT SHALL BE TEMPORARILY RECONNECTED AS SOON AS POSSIBLE AFTER WORK IS COMPLETE IN THAT IMMEDIATE AREA, AND NO LONGER THAN 24 HRS. CONSTRUCTION MANAGER TO BE NOTIFIED WHEN A DOG FENCE HAS BEEN HIT (INCIDENTAL). CONTRACTOR MUST NOTIFY HOME OWNER IMMEDIATELY AFTER DOG FENCE IS HIT. (INCIDENTAL) DOG FENCE REPAIR WILL ONLY BE PAID ONCE PER ADDRESS.

EROSION CONTROL NOTES:

- 1) THE CONTRACTOR SHALL INSTALL AND MAINTAIN EROSION CONTROL FENCE AND SEDIMENT CONTROL LOG AS SHOWN AND AS DIRECTED BY ENGINEER IN FIELD. EROSION FENCE AND SEDIMENT CONTROL LOG TO BE REMOVED BY CONTRACTOR AFTER PERMANENT VEGETATION HAS BEEN ESTABLISHED.
 - 2) THE CONTRACTOR SHALL PLACE STORM SEWER STRUCTURE PROTECTION AT CATCH BASINS AS DIRECTED BY ENGINEER TO PREVENT SEDIMENT FROM ENTERING THE STORM SEWER DURING CONSTRUCTION.
 - 3) THE CONTRACTOR SHALL CONSTRUCT AND MAINTAIN ROCK ENTRANCES AT POINTS OF EXIT FROM PAVEMENT AS DIRECTED BY ENGINEER.
- FOR MORE EROSION CONTROL NOTES SEE GENERAL NOTES – SHEET 7

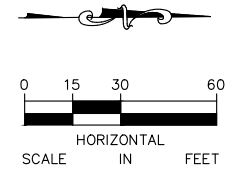

No.	Date	Revisions	App.	DRAWING NAME
				2024_PaveRehab_REM.dwg
				DESIGNED BY: MAK
				DRAWN BY: RCH
				CHECKED BY: MAK
				DATE: 02/29/2024
				PROJECT NO. 24-01

Kimley»Horn

11995 SINGLETREE LANE, SUITE 225, EDEN PRAIRIE, MN 55344
PHONE: 612-315-1272
WWW.KIMLEY-HORN.COM

I HEREBY CERTIFY THAT THIS PLAN, SPECIFICATION OR REPORT WAS PREPARED BY ME OR UNDER MY DIRECT SUPERVISION AND THAT I AM A DULY LICENSED PROFESSIONAL ENGINEER UNDER THE LAWS OF THE STATE OF MINNESOTA.

Michael A. Kirsch
MICHAEL A. KIRSCH
DATE: 02/29/2024 MN LIC. NO. 59057



CITY OF CHANHASSEN
2024 CITY PAVEMENT
REHABILITATION PROJECT

REMOVAL AND EROSION CONTROL PLANS
GREAT PLAINS BOULEVARD
STA. 309+00 TO STA. 314+50

CITY PROJECT	24-01	SHEET NO.
		53
		188

MATCH LINE 20+50

MATCH LINE 26+50

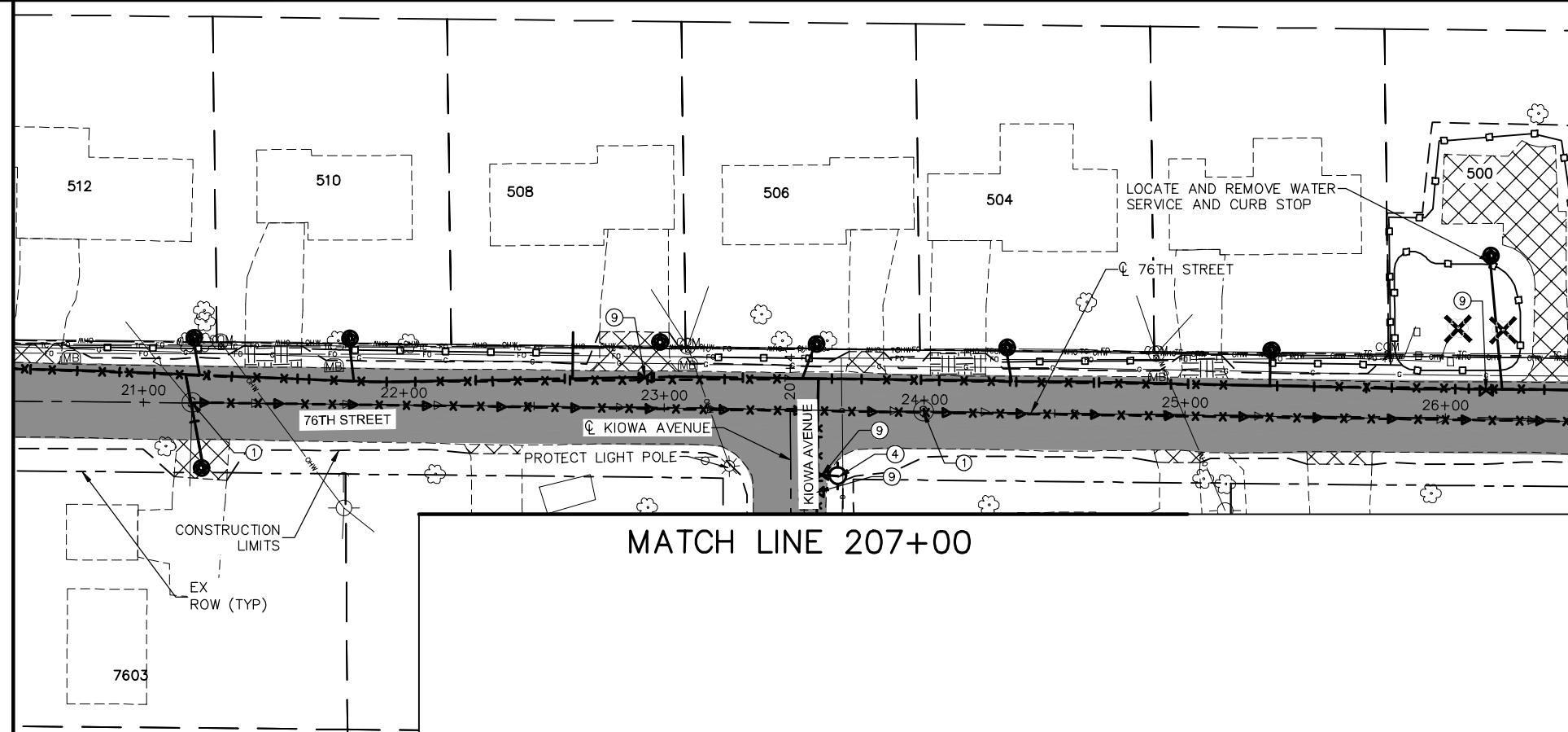

MATCH LINE 207+00

LEGEND:

- 2" BITUMINOUS MILL & OVERLAY
- FULL DEPTH RECLAMATION
- REMOVE FULL DEPTH
- REMOVE CONCRETE SIDEWALK
- REMOVE BITUMINOUS TRAIL
- REMOVE CONCRETE DRIVEWAY
- REMOVE BITUMINOUS DRIVEWAY
- REMOVE PAVER DRIVEWAY
- ROCK CONSTRUCTION ENTRANCE
- FULL DEPTH SAW CUT
- CONSTRUCTION LIMITS
- REMOVE CURB & GUTTER
- EXISTING RIGHT-OF-WAY
- REMOVE STORM SEWER PIPE
- REMOVE SANITARY SEWER PIPE
- REMOVE WATERMAIN PIPE
- CLEAR/GRUBB TREE
- PROTECT TREE
- STORM SEWER STRUCTURE PROTECTION
- SILT FENCE

SPECIFIC NOTES:

- ① REMOVE SANITARY SEWER MANHOLE
- ② REMOVE DRAINAGE STRUCTURE
- ③ ADJUST FRAME AND RINGS
- ④ REMOVE HYDRANT
- ⑤ REMOVE SIGN
- ⑥ EXISTING SPRINKLER SYSTEM – PROTECT IF POSSIBLE
- ⑦ EXISTING INVISIBLE PET FENCE – PROTECT IF POSSIBLE
- ⑧ SALVAGE SIGN
- ⑨ REMOVE GATE VALVE & BOX

REMOVAL NOTES:

- 1) STRIP, STOCKPILE AND REUSE INPLACE TOPSOIL IN AREAS TO BE DISTURBED BY CONSTRUCTION.
- 2) CONTRACTOR SHALL CALL GOPHER STATE ONE CALL AT 651-454-0002. ALL UTILITIES MUST BE LOCATED PRIOR TO THE START OF CONSTRUCTION.
- 3) SEE UTILITY PLANS AND DRAINAGE PLANS FOR UTILITY ADJUSTMENTS AND REPLACEMENTS
- 4) CONTRACTOR SHALL PROTECT ALL EXISTING UTILITY STRUCTURES THAT ARE NOT BEING REMOVED OR RELOCATED.
- 5) TRENCH BOXES OR OTHER TRENCH STABILIZATION METHODS MAY BE REQUIRED DURING CONSTRUCTION TO MINIMIZE REMOVAL LIMITS.
- 6) CONTRACTOR TO VERIFY REMOVAL LIMITS WITH ENGINEER PRIOR TO SAWCUTTING.
- 7) ENGINEER TO IDENTIFY AND MARK CONCRETE CURB AND GUTTER REMOVAL LOCATIONS.
- 8) ENGINEER TO IDENTIFY AND MARK CONCRETE AND BITUMINOUS DRIVEWAYS REMOVAL LOCATIONS.
- 9) ENGINEER TO IDENTIFY AND MARK CONCRETE WALK REMOVAL LOCATIONS.
- 10) COORDINATE WITH POSTAL PATRONS AND LOCAL POSTAL AUTHORITY TO RELOCATE MAILBOXES DURING CONSTRUCTION.
- 11) SEE UTILITY PLAN, SHEETS 68-87 FOR REPAIRS AND REPLACEMENT OF SANITARY SEWER AND WATERMAIN.
- 12) CONTRACTOR SHALL BE RESPONSIBLE FOR LOCATING, PROTECTING, SUPPORTING IRRIGATION AND SHALL TAKE ALL REASONABLE EFFORTS TO PROTECT IRRIGATION SYSTEMS WITHIN THE PROJECT AREA.
- 13) INVISIBLE DOG FENCES THAT ARE HIT SHALL BE TEMPORARILY RECONNECTED AS SOON AS POSSIBLE AFTER WORK IS COMPLETE IN THAT IMMEDIATE AREA, AND NO LONGER THAN 24 HRS. CONSTRUCTION MANAGER TO BE NOTIFIED WHEN A DOG FENCE HAS BEEN HIT (INCIDENTAL). CONTRACTOR MUST NOTIFY HOME OWNER IMMEDIATELY AFTER DOG FENCE IS HIT. (INCIDENTAL) DOG FENCE REPAIR WILL ONLY BE PAID ONCE PER ADDRESS.

EROSION CONTROL NOTES:

- 1) THE CONTRACTOR SHALL INSTALL AND MAINTAIN EROSION CONTROL FENCE AND SEDIMENT CONTROL LOG AS SHOWN AND AS DIRECTED BY ENGINEER IN FIELD. EROSION FENCE AND SEDIMENT CONTROL LOG TO BE REMOVED BY CONTRACTOR AFTER PERMANENT VEGETATION HAS BEEN ESTABLISHED.
 - 2) THE CONTRACTOR SHALL PLACE STORM SEWER STRUCTURE PROTECTION AT CATCH BASINS AS DIRECTED BY ENGINEER TO PREVENT SEDIMENT FROM ENTERING THE STORM SEWER DURING CONSTRUCTION.
 - 3) THE CONTRACTOR SHALL CONSTRUCT AND MAINTAIN ROCK ENTRANCES AT POINTS OF EXIT FROM PAVEMENT AS DIRECTED BY ENGINEER.
- FOR MORE EROSION CONTROL NOTES SEE GENERAL NOTES – SHEET 7

k:\TOW_Civil\City\CHANHASSEN\2024 CITY STREET REHAB-RECON\CAD\Plan Sheets\2024_PaveRehab_REM.dwg March 01, 2024 - 2:05pm

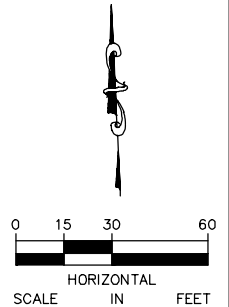

No.	Date	Revisions	App.

DRAWING NAME	2024_PaveRehab_REM.dwg
DESIGNED BY:	MAK
DRAWN BY:	RCH
CHECKED BY:	MAK
DATE:	02/29/2024
PROJECT NO.	24-01

Kimley»Horn

11995 SINGLETREE LANE, SUITE 225, EDEN PRAIRIE, MN 55344
 PHONE: 612-315-1272
 WWW.KIMLEY-HORN.COM

I HEREBY CERTIFY THAT THIS PLAN, SPECIFICATION OR REPORT WAS PREPARED BY ME OR UNDER MY DIRECT SUPERVISION AND THAT I AM A DULY LICENSED PROFESSIONAL ENGINEER UNDER THE LAWS OF THE STATE OF MINNESOTA.

Michael A. Kirsch
 MICHAEL A. KIRSCH
 DATE: 02/29/2024 MN LIC. NO. 59057



CITY OF CHANHASSEN
 2024 CITY PAVEMENT
 REHABILITATION PROJECT

REMOVAL AND EROSION CONTROL PLANS
 76TH STREET
 STA. 20+50 TO STA. 26+50

CITY PROJECT 24-01

SHEET NO.
54
 188

MATCH LINE 26+50

MATCH LINE 33+00

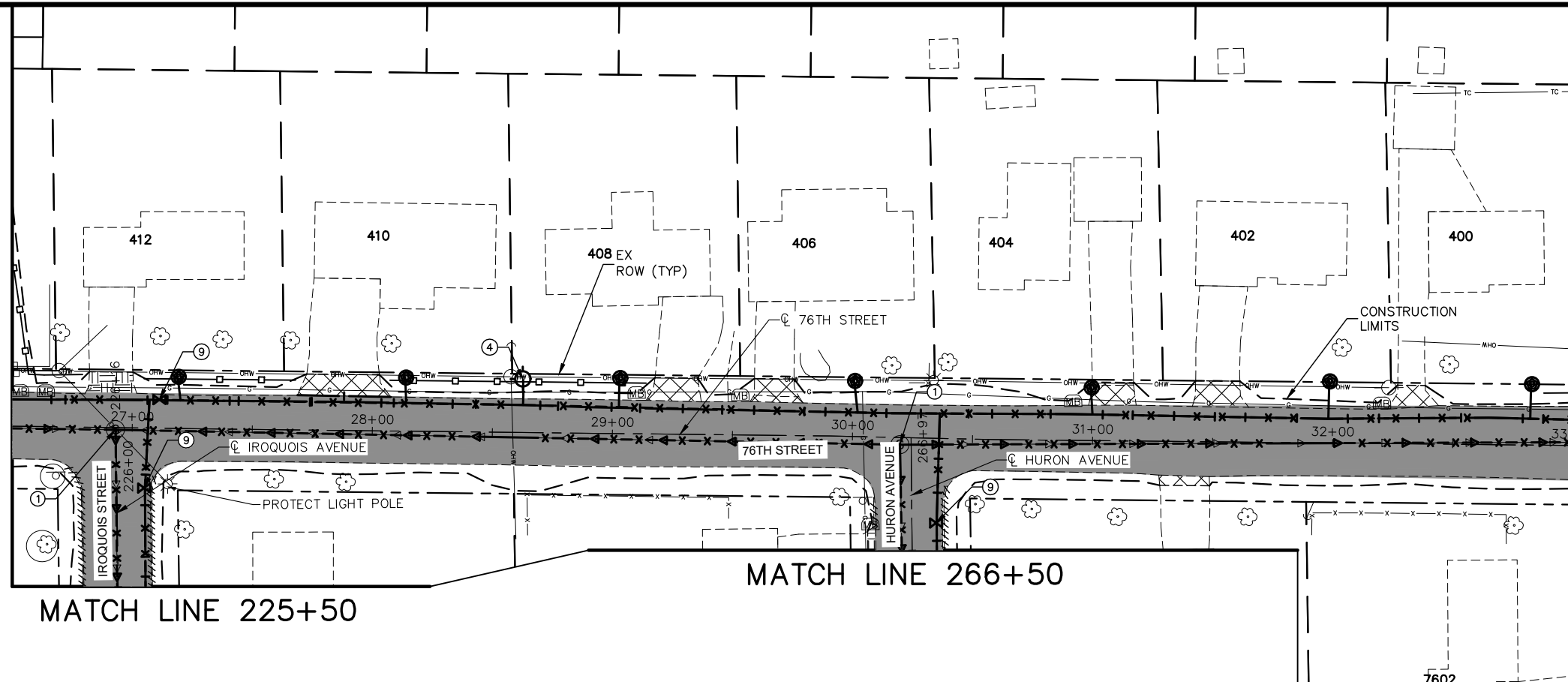

MATCH LINE 225+50

MATCH LINE 266+50

7602

LEGEND:

- 2" BITUMINOUS MILL & OVERLAY
- FULL DEPTH RECLAMATION
- REMOVE FULL DEPTH
- REMOVE CONCRETE SIDEWALK
- REMOVE BITUMINOUS TRAIL
- REMOVE CONCRETE DRIVEWAY
- REMOVE BITUMINOUS DRIVEWAY
- REMOVE PAVER DRIVEWAY
- ROCK CONSTRUCTION ENTRANCE
- FULL DEPTH SAW CUT
- CONSTRUCTION LIMITS
- REMOVE CURB & GUTTER
- EXISTING RIGHT-OF-WAY
- REMOVE STORM SEWER PIPE
- REMOVE SANITARY SEWER PIPE
- REMOVE WATERMAIN PIPE
- CLEAR/GRUBB TREE
- PROTECT TREE
- STORM SEWER STRUCTURE PROTECTION
- SILT FENCE

SPECIFIC NOTES:

- ① REMOVE SANITARY SEWER MANHOLE
- ② REMOVE DRAINAGE STRUCTURE
- ③ ADJUST FRAME AND RINGS
- ④ REMOVE HYDRANT
- ⑤ REMOVE SIGN
- ⑥ EXISTING SPRINKLER SYSTEM – PROTECT IF POSSIBLE
- ⑦ EXISTING INVISIBLE PET FENCE – PROTECT IF POSSIBLE
- ⑧ SALVAGE SIGN
- ⑨ REMOVE GATE VALVE & BOX

REMOVAL NOTES:

- 1) STRIP, STOCKPILE AND REUSE INPLACE TOPSOIL IN AREAS TO BE DISTURBED BY CONSTRUCTION.
- 2) CONTRACTOR SHALL CALL GOPHER STATE ONE CALL AT 651-454-0002. ALL UTILITIES MUST BE LOCATED PRIOR TO THE START OF CONSTRUCTION.
- 3) SEE UTILITY PLANS AND DRAINAGE PLANS FOR UTILITY ADJUSTMENTS AND REPLACEMENTS
- 4) CONTRACTOR SHALL PROTECT ALL EXISTING UTILITY STRUCTURES THAT ARE NOT BEING REMOVED OR RELOCATED.
- 5) TRENCH BOXES OR OTHER TRENCH STABILIZATION METHODS MAY BE REQUIRED DURING CONSTRUCTION TO MINIMIZE REMOVAL LIMITS.
- 6) CONTRACTOR TO VERIFY REMOVAL LIMITS WITH ENGINEER PRIOR TO SAWCUTTING.
- 7) ENGINEER TO IDENTIFY AND MARK CONCRETE CURB AND GUTTER REMOVAL LOCATIONS.
- 8) ENGINEER TO IDENTIFY AND MARK CONCRETE AND BITUMINOUS DRIVEWAYS REMOVAL LOCATIONS.
- 9) ENGINEER TO IDENTIFY AND MARK CONCRETE WALK REMOVAL LOCATIONS.
- 10) COORDINATE WITH POSTAL PATRONS AND LOCAL POSTAL AUTHORITY TO RELOCATE MAILBOXES DURING CONSTRUCTION.
- 11) SEE UTILITY PLAN, SHEETS 68-87 FOR REPAIRS AND REPLACEMENT OF SANITARY SEWER AND WATERMAIN.
- 12) CONTRACTOR SHALL BE RESPONSIBLE FOR LOCATING, PROTECTING, SUPPORTING IRRIGATION AND SHALL TAKE ALL REASONABLE EFFORTS TO PROTECT IRRIGATION SYSTEMS WITHIN THE PROJECT AREA.
- 13) INVISIBLE DOG FENCES THAT ARE HIT SHALL BE TEMPORARILY RECONNECTED AS SOON AS POSSIBLE AFTER WORK IS COMPLETE IN THAT IMMEDIATE AREA, AND NO LONGER THAN 24 HRS. CONSTRUCTION MANAGER TO BE NOTIFIED WHEN A DOG FENCE HAS BEEN HIT (INCIDENTAL). CONTRACTOR MUST NOTIFY HOME OWNER IMMEDIATELY AFTER DOG FENCE IS HIT. (INCIDENTAL) DOG FENCE REPAIR WILL ONLY BE PAID ONCE PER ADDRESS.

EROSION CONTROL NOTES:

- 1) THE CONTRACTOR SHALL INSTALL AND MAINTAIN EROSION CONTROL FENCE AND SEDIMENT CONTROL LOG AS SHOWN AND AS DIRECTED BY ENGINEER IN FIELD. EROSION FENCE AND SEDIMENT CONTROL LOG TO BE REMOVED BY CONTRACTOR AFTER PERMANENT VEGETATION HAS BEEN ESTABLISHED.
 - 2) THE CONTRACTOR SHALL PLACE STORM SEWER STRUCTURE PROTECTION AT CATCH BASINS AS DIRECTED BY ENGINEER TO PREVENT SEDIMENT FROM ENTERING THE STORM SEWER DURING CONSTRUCTION.
 - 3) THE CONTRACTOR SHALL CONSTRUCT AND MAINTAIN ROCK ENTRANCES AT POINTS OF EXIT FROM PAVEMENT AS DIRECTED BY ENGINEER.
- FOR MORE EROSION CONTROL NOTES SEE GENERAL NOTES – SHEET 7

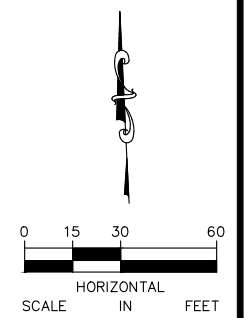

K:\TOW_Civil\Chanhasse\2024_CITY STREET REHAB-RECONSTRUCT\CAD\Plan Sheets\2024_PaveRehab_REM.dwg February 29, 2024 - 6:58pm

No.	Date	Revisions	App.	DRAWING NAME
				2024_PaveRehab_REM.dwg
				DESIGNED BY: MAK
				DRAWN BY: RCH
				CHECKED BY: MAK
				DATE: 02/29/2024
				PROJECT NO. 24-01

Kimley»Horn

11995 SINGLETREE LANE, SUITE 225, EDEN PRAIRIE, MN 55344
PHONE: 612-315-1272
WWW.KIMLEY-HORN.COM

I HEREBY CERTIFY THAT THIS PLAN, SPECIFICATION OR REPORT WAS PREPARED BY ME OR UNDER MY DIRECT SUPERVISION AND THAT I AM A DULY LICENSED PROFESSIONAL ENGINEER UNDER THE LAWS OF THE STATE OF MINNESOTA.

Michael A. Kirsch
MICHAEL A. KIRSCH
DATE: 02/29/2024 MN LIC. NO. 59057

CITY OF CHANHASSEN
2024 CITY PAVEMENT
REHABILITATION PROJECT

REMOVAL AND EROSION CONTROL PLANS
76TH STREET
STA. 26+50 TO STA. 33+00

CITY PROJECT	24-01	SHEET NO.
		55
		188

K:\TOW_Civil\ChanHassen\2024_City Street Rehab-Reconst\CAD\Plan Sheets\2024_PaveRehab_REM.dwg February 29, 2024 - 6:58pm

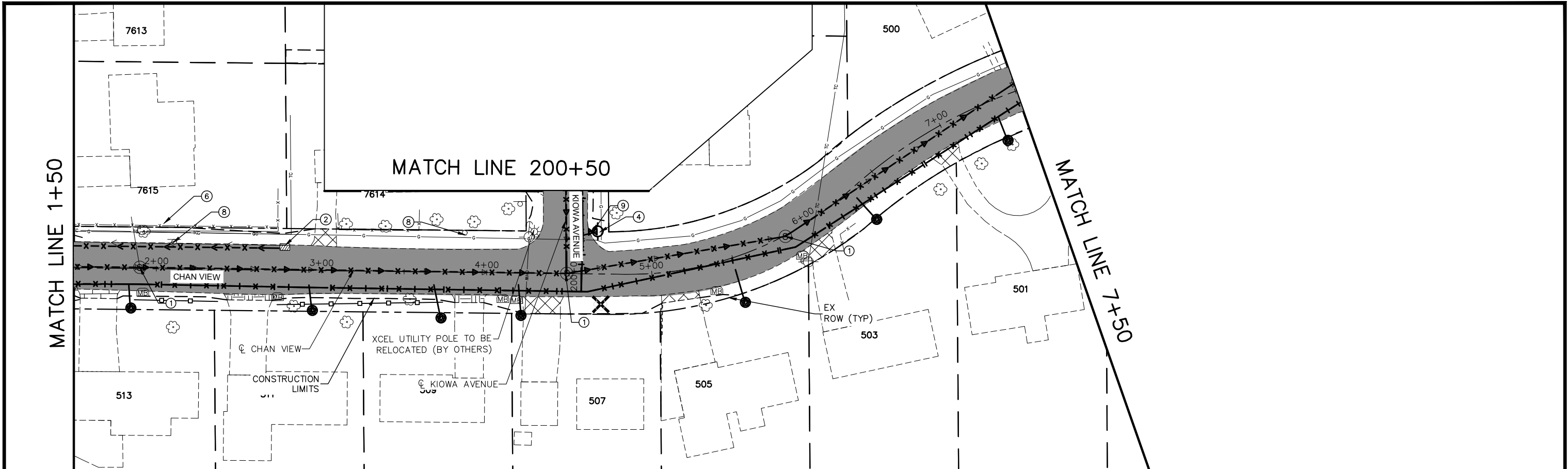

LEGEND:

	2" BITUMINOUS MILL & OVERLAY
	FULL DEPTH RECLAMATION
	REMOVE FULL DEPTH
	REMOVE CONCRETE SIDEWALK
	REMOVE BITUMINOUS TRAIL
	REMOVE CONCRETE DRIVEWAY
	REMOVE BITUMINOUS DRIVEWAY
	REMOVE PAVER DRIVEWAY
	ROCK CONSTRUCTION ENTRANCE
	FULL DEPTH SAW CUT
	CONSTRUCTION LIMITS
	REMOVE CURB & GUTTER
	EXISTING RIGHT-OF-WAY
	REMOVE STORM SEWER PIPE
	REMOVE SANITARY SEWER PIPE
	REMOVE WATERMAIN PIPE
	CLEAR/GRUBB TREE
	PROTECT TREE
	STORM SEWER STRUCTURE PROTECTION
	SILT FENCE

- SPECIFIC NOTES:**
- ① REMOVE SANITARY SEWER MANHOLE
 - ② REMOVE DRAINAGE STRUCTURE
 - ③ ADJUST FRAME AND RINGS
 - ④ REMOVE HYDRANT
 - ⑤ REMOVE SIGN
 - ⑥ EXISTING SPRINKLER SYSTEM – PROTECT IF POSSIBLE
 - ⑦ EXISTING INVISIBLE PET FENCE – PROTECT IF POSSIBLE
 - ⑧ SALVAGE SIGN
 - ⑨ REMOVE GATE VALVE & BOX

- REMOVAL NOTES:**
- 1) STRIP, STOCKPILE AND REUSE INPLACE TOPSOIL IN AREAS TO BE DISTURBED BY CONSTRUCTION.
 - 2) CONTRACTOR SHALL CALL GOPHER STATE ONE CALL AT 651-454-0002. ALL UTILITIES MUST BE LOCATED PRIOR TO THE START OF CONSTRUCTION.
 - 3) SEE UTILITY PLANS AND DRAINAGE PLANS FOR UTILITY ADJUSTMENTS AND REPLACEMENTS
 - 4) CONTRACTOR SHALL PROTECT ALL EXISTING UTILITY STRUCTURES THAT ARE NOT BEING REMOVED OR RELOCATED.
 - 5) TRENCH BOXES OR OTHER TRENCH STABILIZATION METHODS MAY BE REQUIRED DURING CONSTRUCTION TO MINIMIZE REMOVAL LIMITS.
 - 6) CONTRACTOR TO VERIFY REMOVAL LIMITS WITH ENGINEER PRIOR TO SAWCUTTING.
 - 7) ENGINEER TO IDENTIFY AND MARK CONCRETE CURB AND GUTTER REMOVAL LOCATIONS.
 - 8) ENGINEER TO IDENTIFY AND MARK CONCRETE AND BITUMINOUS DRIVEWAYS REMOVAL LOCATIONS.
 - 9) ENGINEER TO IDENTIFY AND MARK CONCRETE WALK REMOVAL LOCATIONS.
 - 10) COORDINATE WITH POSTAL PATRONS AND LOCAL POSTAL AUTHORITY TO RELOCATE MAILBOXES DURING CONSTRUCTION.
 - 11) SEE UTILITY PLAN, SHEETS 68-87 FOR REPAIRS AND REPLACEMENT OF SANITARY SEWER AND WATERMAIN.
 - 12) CONTRACTOR SHALL BE RESPONSIBLE FOR LOCATING, PROTECTING, SUPPORTING IRRIGATION AND SHALL TAKE ALL REASONABLE EFFORTS TO PROTECT IRRIGATION SYSTEMS WITHIN THE PROJECT AREA.
 - 13) INVISIBLE DOG FENCES THAT ARE HIT SHALL BE TEMPORARILY RECONNECTED AS SOON AS POSSIBLE AFTER WORK IS COMPLETE IN THAT IMMEDIATE AREA, AND NO LONGER THAN 24 HRS. CONSTRUCTION MANAGER TO BE NOTIFIED WHEN A DOG FENCE HAS BEEN HIT (INCIDENTAL). CONTRACTOR MUST NOTIFY HOME OWNER IMMEDIATELY AFTER DOG FENCE IS HIT. (INCIDENTAL) DOG FENCE REPAIR WILL ONLY BE PAID ONCE PER ADDRESS.

- EROSION CONTROL NOTES:**
- 1) THE CONTRACTOR SHALL INSTALL AND MAINTAIN EROSION CONTROL FENCE AND SEDIMENT CONTROL LOG AS SHOWN AND AS DIRECTED BY ENGINEER IN FIELD. EROSION FENCE AND SEDIMENT CONTROL LOG TO BE REMOVED BY CONTRACTOR AFTER PERMANENT VEGETATION HAS BEEN ESTABLISHED.
 - 2) THE CONTRACTOR SHALL PLACE STORM SEWER STRUCTURE PROTECTION AT CATCH BASINS AS DIRECTED BY ENGINEER TO PREVENT SEDIMENT FROM ENTERING THE STORM SEWER DURING CONSTRUCTION.
 - 3) THE CONTRACTOR SHALL CONSTRUCT AND MAINTAIN ROCK ENTRANCES AT POINTS OF EXIT FROM PAVEMENT AS DIRECTED BY ENGINEER.
- FOR MORE EROSION CONTROL NOTES SEE GENERAL NOTES – SHEET 7

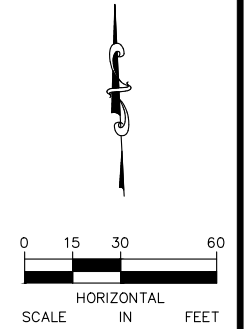

No.	Date	Revisions	App.

DRAWING NAME	2024_PaveRehab_REM.dwg
DESIGNED BY:	MAK
DRAWN BY:	RCH
CHECKED BY:	MAK
DATE:	02/29/2024
PROJECT NO.	24-01

Kimley»Horn

11995 SINGLETREE LANE, SUITE 225, EDEN PRAIRIE, MN 55344
 PHONE: 612-315-1272
 WWW.KIMLEY-HORN.COM

I HEREBY CERTIFY THAT THIS PLAN, SPECIFICATION OR REPORT WAS PREPARED BY ME OR UNDER MY DIRECT SUPERVISION AND THAT I AM A DULY LICENSED PROFESSIONAL ENGINEER UNDER THE LAWS OF THE STATE OF MINNESOTA.

Michael A. Kirsch
 MICHAEL A. KIRSCH
 DATE: 02/29/2024 MN LIC. NO. 59057

 CITY OF CHANHASSEN 2024 CITY PAVEMENT REHABILITATION PROJECT REMOVAL AND EROSION CONTROL PLANS CHAN VIEW STA. 1+50 TO STA. 7+50	CITY PROJECT 24-01	SHEET NO. 56
	SCALE IN FEET	188

K:\TOW_Civil\Chanhasse\2024_City Street Rehab-Reconst\CAD\Plan Sheets\2024_PaveRehab_REM.dwg February 29, 2024 - 6:58pm

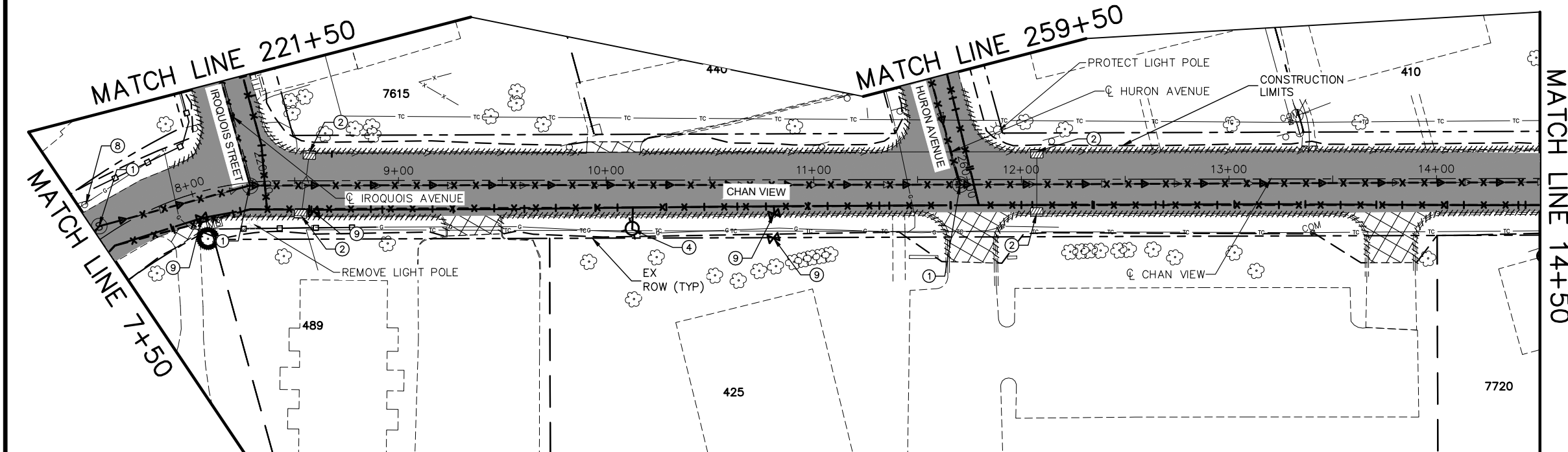

LEGEND:

	2" BITUMINOUS MILL & OVERLAY
	FULL DEPTH RECLAMATION
	REMOVE FULL DEPTH
	REMOVE CONCRETE SIDEWALK
	REMOVE BITUMINOUS TRAIL
	REMOVE CONCRETE DRIVEWAY
	REMOVE BITUMINOUS DRIVEWAY
	REMOVE PAVER DRIVEWAY
	ROCK CONSTRUCTION ENTRANCE
	FULL DEPTH SAW CUT
	CONSTRUCTION LIMITS
	REMOVE CURB & GUTTER
	EXISTING RIGHT-OF-WAY
	REMOVE STORM SEWER PIPE
	REMOVE SANITARY SEWER PIPE
	REMOVE WATERMAIN PIPE
	CLEAR/GRUBB TREE
	PROTECT TREE
	STORM SEWER STRUCTURE PROTECTION
	SILT FENCE

- SPECIFIC NOTES:**
- ① REMOVE SANITARY SEWER MANHOLE
 - ② REMOVE DRAINAGE STRUCTURE
 - ③ ADJUST FRAME AND RINGS
 - ④ REMOVE HYDRANT
 - ⑤ REMOVE SIGN
 - ⑥ EXISTING SPRINKLER SYSTEM – PROTECT IF POSSIBLE
 - ⑦ EXISTING INVISIBLE PET FENCE – PROTECT IF POSSIBLE
 - ⑧ SALVAGE SIGN
 - ⑨ REMOVE GATE VALVE & BOX

- REMOVAL NOTES:**
- 1) STRIP, STOCKPILE AND REUSE INPLACE TOPSOIL IN AREAS TO BE DISTURBED BY CONSTRUCTION.
 - 2) CONTRACTOR SHALL CALL GOPHER STATE ONE CALL AT 651-454-0002. ALL UTILITIES MUST BE LOCATED PRIOR TO THE START OF CONSTRUCTION.
 - 3) SEE UTILITY PLANS AND DRAINAGE PLANS FOR UTILITY ADJUSTMENTS AND REPLACEMENTS
 - 4) CONTRACTOR SHALL PROTECT ALL EXISTING UTILITY STRUCTURES THAT ARE NOT BEING REMOVED OR RELOCATED.
 - 5) TRENCH BOXES OR OTHER TRENCH STABILIZATION METHODS MAY BE REQUIRED DURING CONSTRUCTION TO MINIMIZE REMOVAL LIMITS.
 - 6) CONTRACTOR TO VERIFY REMOVAL LIMITS WITH ENGINEER PRIOR TO SAWCUTTING.
 - 7) ENGINEER TO IDENTIFY AND MARK CONCRETE CURB AND GUTTER REMOVAL LOCATIONS.
 - 8) ENGINEER TO IDENTIFY AND MARK CONCRETE AND BITUMINOUS DRIVEWAYS REMOVAL LOCATIONS.
 - 9) ENGINEER TO IDENTIFY AND MARK CONCRETE WALK REMOVAL LOCATIONS.
 - 10) COORDINATE WITH POSTAL PATRONS AND LOCAL POSTAL AUTHORITY TO RELOCATE MAILBOXES DURING CONSTRUCTION.
 - 11) SEE UTILITY PLAN, SHEETS 68-87 FOR REPAIRS AND REPLACEMENT OF SANITARY SEWER AND WATERMAIN.
 - 12) CONTRACTOR SHALL BE RESPONSIBLE FOR LOCATING, PROTECTING, SUPPORTING IRRIGATION AND SHALL TAKE ALL REASONABLE EFFORTS TO PROTECT IRRIGATION SYSTEMS WITHIN THE PROJECT AREA.
 - 13) INVISIBLE DOG FENCES THAT ARE HIT SHALL BE TEMPORARILY RECONNECTED AS SOON AS POSSIBLE AFTER WORK IS COMPLETE IN THAT IMMEDIATE AREA, AND NO LONGER THAN 24 HRS. CONSTRUCTION MANAGER TO BE NOTIFIED WHEN A DOG FENCE HAS BEEN HIT (INCIDENTAL). CONTRACTOR MUST NOTIFY HOME OWNER IMMEDIATELY AFTER DOG FENCE IS HIT. (INCIDENTAL) DOG FENCE REPAIR WILL ONLY BE PAID ONCE PER ADDRESS.

- EROSION CONTROL NOTES:**
- 1) THE CONTRACTOR SHALL INSTALL AND MAINTAIN EROSION CONTROL FENCE AND SEDIMENT CONTROL LOG AS SHOWN AND AS DIRECTED BY ENGINEER IN FIELD. EROSION FENCE AND SEDIMENT CONTROL LOG TO BE REMOVED BY CONTRACTOR AFTER PERMANENT VEGETATION HAS BEEN ESTABLISHED.
 - 2) THE CONTRACTOR SHALL PLACE STORM SEWER STRUCTURE PROTECTION AT CATCH BASINS AS DIRECTED BY ENGINEER TO PREVENT SEDIMENT FROM ENTERING THE STORM SEWER DURING CONSTRUCTION.
 - 3) THE CONTRACTOR SHALL CONSTRUCT AND MAINTAIN ROCK ENTRANCES AT POINTS OF EXIT FROM PAVEMENT AS DIRECTED BY ENGINEER.
- FOR MORE EROSION CONTROL NOTES SEE GENERAL NOTES – SHEET 7

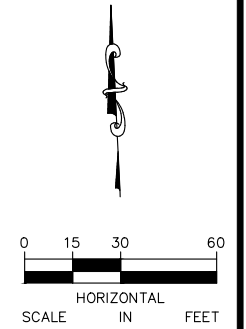

No.	Date	Revisions	App.	DRAWING NAME
				2024_PaveRehab_REM.dwg
				DESIGNED BY: MAK
				DRAWN BY: RCH
				CHECKED BY: MAK
				DATE: 02/29/2024
				PROJECT NO. 24-01

Kimley»Horn

11995 SINGLETREE LANE, SUITE 225, EDEN PRAIRIE, MN 55344
 PHONE: 612-315-1272
 WWW.KIMLEY-HORN.COM

I HEREBY CERTIFY THAT THIS PLAN, SPECIFICATION OR REPORT WAS PREPARED BY ME OR UNDER MY DIRECT SUPERVISION AND THAT I AM A DULY LICENSED PROFESSIONAL ENGINEER UNDER THE LAWS OF THE STATE OF MINNESOTA.

Michael A. Kirsch
 MICHAEL A. KIRSCH
 DATE: 02/29/2024 MN LIC. NO. 59057



CITY OF CHANHASSE
 2024 CITY PAVEMENT
 REHABILITATION PROJECT

REMOVAL AND EROSION CONTROL PLANS
 CHAN VIEW
 STA. 7+50 TO STA. 14+50

CITY PROJECT	24-01	SHEET NO.
		57
		188

K:\TOW_Civil\City\CHANHASSEN\2024 CITY STREET REHAB-RECONSTRUCT\CAD\Plan Sheets\2024_PaveRehab_REM.dwg February 29, 2024 - 6:59pm

MATCH LINE 220+50

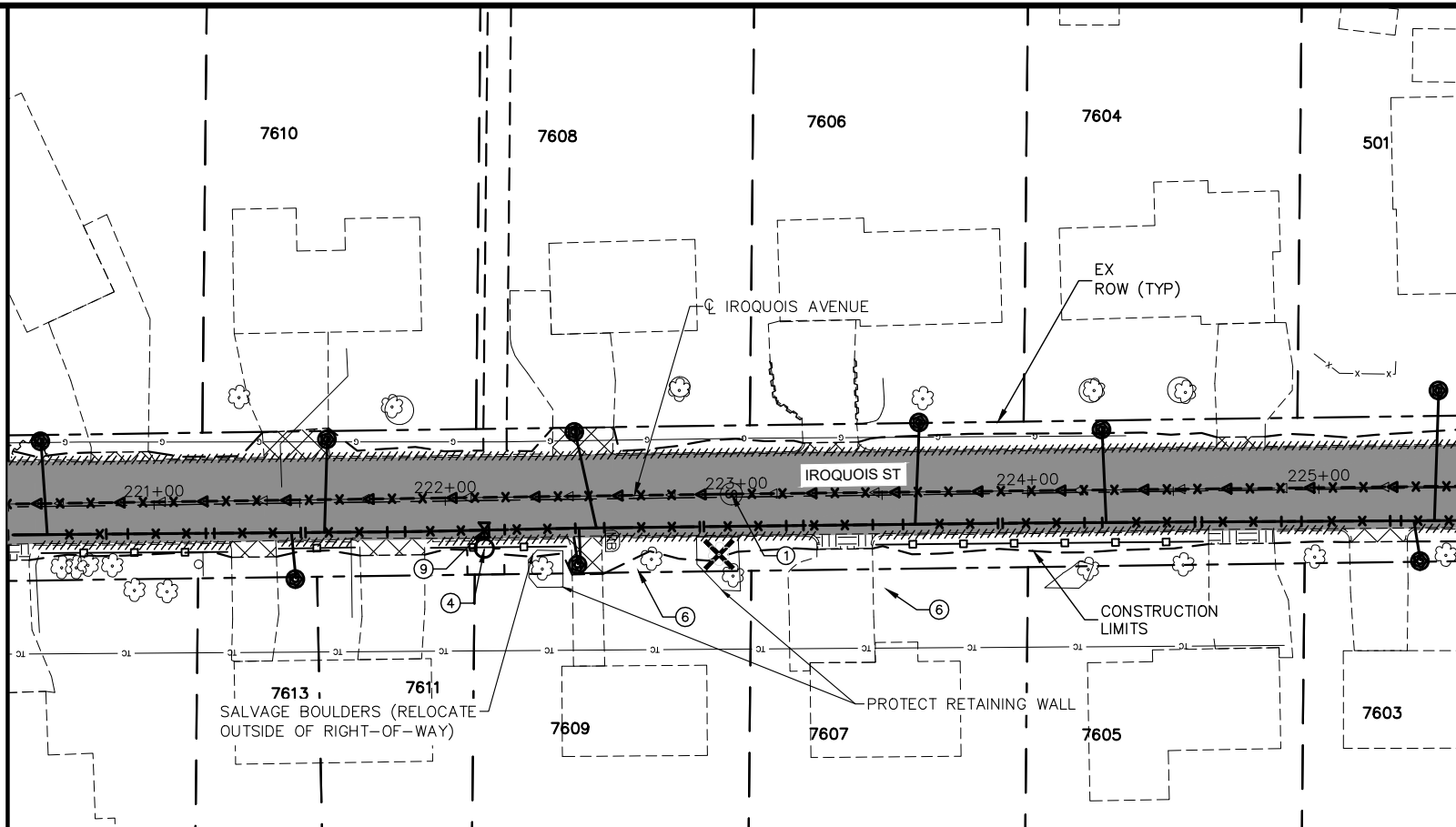

MATCH LINE 225+50

LEGEND:

- 2" BITUMINOUS MILL & OVERLAY
- FULL DEPTH RECLAMATION
- REMOVE FULL DEPTH
- REMOVE CONCRETE SIDEWALK
- REMOVE BITUMINOUS TRAIL
- REMOVE CONCRETE DRIVEWAY
- REMOVE BITUMINOUS DRIVEWAY
- REMOVE PAVER DRIVEWAY
- ROCK CONSTRUCTION ENTRANCE
- FULL DEPTH SAW CUT
- CONSTRUCTION LIMITS
- REMOVE CURB & GUTTER
- EXISTING RIGHT-OF-WAY
- REMOVE STORM SEWER PIPE
- REMOVE SANITARY SEWER PIPE
- REMOVE WATERMAIN PIPE
- CLEAR/GRUBB TREE
- PROTECT TREE
- STORM SEWER STRUCTURE PROTECTION
- SILT FENCE

SPECIFIC NOTES:

- ① REMOVE SANITARY SEWER MANHOLE
- ② REMOVE DRAINAGE STRUCTURE
- ③ ADJUST FRAME AND RINGS
- ④ REMOVE HYDRANT
- ⑤ REMOVE SIGN
- ⑥ EXISTING SPRINKLER SYSTEM – PROTECT IF POSSIBLE
- ⑦ EXISTING INVISIBLE PET FENCE – PROTECT IF POSSIBLE
- ⑧ SALVAGE SIGN
- ⑨ REMOVE GATE VALVE & BOX

REMOVAL NOTES:

- 1) STRIP, STOCKPILE AND REUSE INPLACE TOPSOIL IN AREAS TO BE DISTURBED BY CONSTRUCTION.
- 2) CONTRACTOR SHALL CALL GOPHER STATE ONE CALL AT 651-454-0002. ALL UTILITIES MUST BE LOCATED PRIOR TO THE START OF CONSTRUCTION.
- 3) SEE UTILITY PLANS AND DRAINAGE PLANS FOR UTILITY ADJUSTMENTS AND REPLACEMENTS
- 4) CONTRACTOR SHALL PROTECT ALL EXISTING UTILITY STRUCTURES THAT ARE NOT BEING REMOVED OR RELOCATED.
- 5) TRENCH BOXES OR OTHER TRENCH STABILIZATION METHODS MAY BE REQUIRED DURING CONSTRUCTION TO MINIMIZE REMOVAL LIMITS.
- 6) CONTRACTOR TO VERIFY REMOVAL LIMITS WITH ENGINEER PRIOR TO SAWCUTTING.
- 7) ENGINEER TO IDENTIFY AND MARK CONCRETE CURB AND GUTTER REMOVAL LOCATIONS.
- 8) ENGINEER TO IDENTIFY AND MARK CONCRETE AND BITUMINOUS DRIVEWAYS REMOVAL LOCATIONS.
- 9) ENGINEER TO IDENTIFY AND MARK CONCRETE WALK REMOVAL LOCATIONS.
- 10) COORDINATE WITH POSTAL PATRONS AND LOCAL POSTAL AUTHORITY TO RELOCATE MAILBOXES DURING CONSTRUCTION.
- 11) SEE UTILITY PLAN, SHEETS 68-87 FOR REPAIRS AND REPLACEMENT OF SANITARY SEWER AND WATERMAIN.
- 12) CONTRACTOR SHALL BE RESPONSIBLE FOR LOCATING, PROTECTING, SUPPORTING IRRIGATION AND SHALL TAKE ALL REASONABLE EFFORTS TO PROTECT IRRIGATION SYSTEMS WITHIN THE PROJECT AREA.
- 13) INVISIBLE DOG FENCES THAT ARE HIT SHALL BE TEMPORARILY RECONNECTED AS SOON AS POSSIBLE AFTER WORK IS COMPLETE IN THAT IMMEDIATE AREA, AND NO LONGER THAN 24 HRS. CONSTRUCTION MANAGER TO BE NOTIFIED WHEN A DOG FENCE HAS BEEN HIT (INCIDENTAL). CONTRACTOR MUST NOTIFY HOME OWNER IMMEDIATELY AFTER DOG FENCE IS HIT. (INCIDENTAL) DOG FENCE REPAIR WILL ONLY BE PAID ONCE PER ADDRESS.

EROSION CONTROL NOTES:

- 1) THE CONTRACTOR SHALL INSTALL AND MAINTAIN EROSION CONTROL FENCE AND SEDIMENT CONTROL LOG AS SHOWN AND AS DIRECTED BY ENGINEER IN FIELD. EROSION FENCE AND SEDIMENT CONTROL LOG TO BE REMOVED BY CONTRACTOR AFTER PERMANENT VEGETATION HAS BEEN ESTABLISHED.
 - 2) THE CONTRACTOR SHALL PLACE STORM SEWER STRUCTURE PROTECTION AT CATCH BASINS AS DIRECTED BY ENGINEER TO PREVENT SEDIMENT FROM ENTERING THE STORM SEWER DURING CONSTRUCTION.
 - 3) THE CONTRACTOR SHALL CONSTRUCT AND MAINTAIN ROCK ENTRANCES AT POINTS OF EXIT FROM PAVEMENT AS DIRECTED BY ENGINEER.
- FOR MORE EROSION CONTROL NOTES SEE GENERAL NOTES – SHEET 7

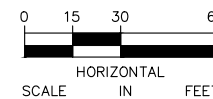

No.	Date	Revisions	App.	DRAWING NAME
				2024_PaveRehab_REM.dwg
				DESIGNED BY: MAK
				DRAWN BY: RCH
				CHECKED BY: MAK
				DATE: 02/29/2024
				PROJECT NO. 24-01



11995 SINGLETREE LANE, SUITE 225, EDEN PRAIRIE, MN 55344
PHONE: 612-315-1272
WWW.KIMLEY-HORN.COM

I HEREBY CERTIFY THAT THIS PLAN, SPECIFICATION OR REPORT WAS PREPARED BY ME OR UNDER MY DIRECT SUPERVISION AND THAT I AM A DULY LICENSED PROFESSIONAL ENGINEER UNDER THE LAWS OF THE STATE OF MINNESOTA.

Michael Kirsch
MICHAEL A. KIRSCH
DATE: 02/29/2024 MN LIC. NO. 59057



CITY OF CHANHASSEN
2024 CITY PAVEMENT
REHABILITATION PROJECT

REMOVAL AND EROSION CONTROL PLANS
IROQUOIS STREET
STA. 220+50 TO STA. 225+50

CITY PROJECT 24-01 SHEET NO.

59

188

K:\TOW_Civil\City\CHANHASSEN\2024_CITY STREET REHAB-RECONSTRUCT\CAD\Plan Sheets\2024_PaveRehab_REM.dwg February 29, 2024 - 6:59pm

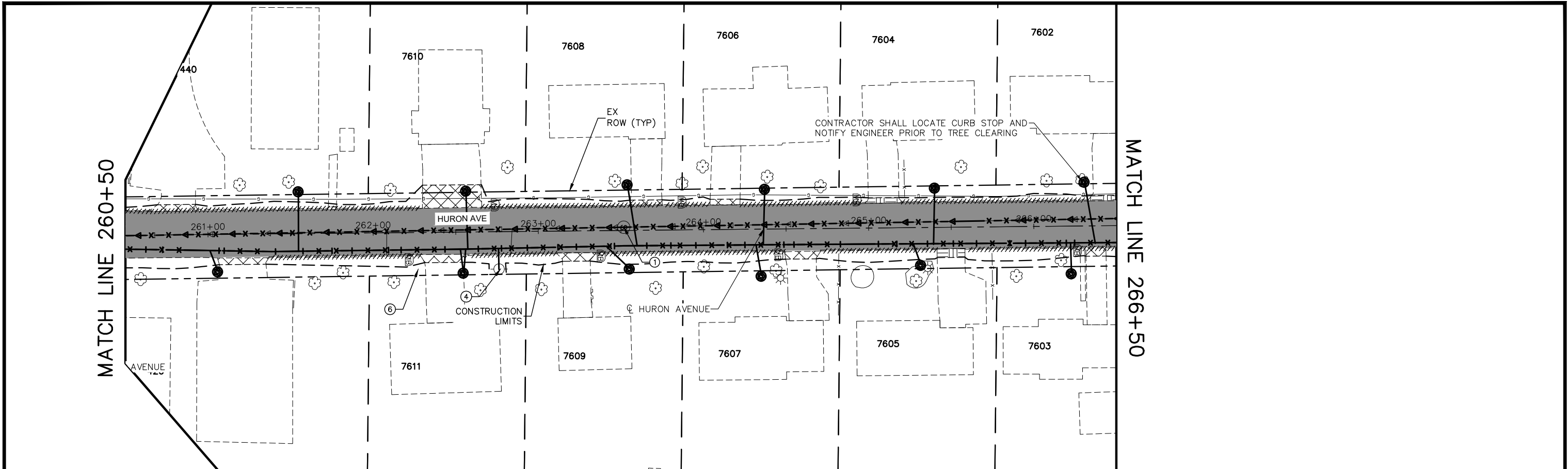

LEGEND:

	2" BITUMINOUS MILL & OVERLAY
	FULL DEPTH RECLAMATION
	REMOVE FULL DEPTH
	REMOVE CONCRETE SIDEWALK
	REMOVE BITUMINOUS TRAIL
	REMOVE CONCRETE DRIVEWAY
	REMOVE BITUMINOUS DRIVEWAY
	REMOVE PAVER DRIVEWAY
	ROCK CONSTRUCTION ENTRANCE
	FULL DEPTH SAW CUT
	CONSTRUCTION LIMITS
	REMOVE CURB & GUTTER
	EXISTING RIGHT-OF-WAY
	REMOVE STORM SEWER PIPE
	REMOVE SANITARY SEWER PIPE
	REMOVE WATERMAIN PIPE
	CLEAR/GRUBB TREE
	PROTECT TREE
	STORM SEWER STRUCTURE PROTECTION
	SILT FENCE

- SPECIFIC NOTES:**
- ① REMOVE SANITARY SEWER MANHOLE
 - ② REMOVE DRAINAGE STRUCTURE
 - ③ ADJUST FRAME AND RINGS
 - ④ REMOVE HYDRANT
 - ⑤ REMOVE SIGN
 - ⑥ EXISTING SPRINKLER SYSTEM – PROTECT IF POSSIBLE
 - ⑦ EXISTING INVISIBLE PET FENCE – PROTECT IF POSSIBLE
 - ⑧ SALVAGE SIGN
 - ⑨ REMOVE GATE VALVE & BOX

- REMOVAL NOTES:**
- 1) STRIP, STOCKPILE AND REUSE INPLACE TOPSOIL IN AREAS TO BE DISTURBED BY CONSTRUCTION.
 - 2) CONTRACTOR SHALL CALL GOPHER STATE ONE CALL AT 651-454-0002. ALL UTILITIES MUST BE LOCATED PRIOR TO THE START OF CONSTRUCTION.
 - 3) SEE UTILITY PLANS AND DRAINAGE PLANS FOR UTILITY ADJUSTMENTS AND REPLACEMENTS
 - 4) CONTRACTOR SHALL PROTECT ALL EXISTING UTILITY STRUCTURES THAT ARE NOT BEING REMOVED OR RELOCATED.
 - 5) TRENCH BOXES OR OTHER TRENCH STABILIZATION METHODS MAY BE REQUIRED DURING CONSTRUCTION TO MINIMIZE REMOVAL LIMITS.
 - 6) CONTRACTOR TO VERIFY REMOVAL LIMITS WITH ENGINEER PRIOR TO SAWCUTTING.
 - 7) ENGINEER TO IDENTIFY AND MARK CONCRETE CURB AND GUTTER REMOVAL LOCATIONS.
 - 8) ENGINEER TO IDENTIFY AND MARK CONCRETE AND BITUMINOUS DRIVEWAYS REMOVAL LOCATIONS.
 - 9) ENGINEER TO IDENTIFY AND MARK CONCRETE WALK REMOVAL LOCATIONS.
 - 10) COORDINATE WITH POSTAL PATRONS AND LOCAL POSTAL AUTHORITY TO RELOCATE MAILBOXES DURING CONSTRUCTION.
 - 11) SEE UTILITY PLAN, SHEETS 68-87 FOR REPAIRS AND REPLACEMENT OF SANITARY SEWER AND WATERMAIN.
 - 12) CONTRACTOR SHALL BE RESPONSIBLE FOR LOCATING, PROTECTING, SUPPORTING IRRIGATION AND SHALL TAKE ALL REASONABLE EFFORTS TO PROTECT IRRIGATION SYSTEMS WITHIN THE PROJECT AREA.
 - 13) INVISIBLE DOG FENCES THAT ARE HIT SHALL BE TEMPORARILY RECONNECTED AS SOON AS POSSIBLE AFTER WORK IS COMPLETE IN THAT IMMEDIATE AREA, AND NO LONGER THAN 24 HRS. CONSTRUCTION MANAGER TO BE NOTIFIED WHEN A DOG FENCE HAS BEEN HIT (INCIDENTAL). CONTRACTOR MUST NOTIFY HOME OWNER IMMEDIATELY AFTER DOG FENCE IS HIT. (INCIDENTAL) DOG FENCE REPAIR WILL ONLY BE PAID ONCE PER ADDRESS.

- EROSION CONTROL NOTES:**
- 1) THE CONTRACTOR SHALL INSTALL AND MAINTAIN EROSION CONTROL FENCE AND SEDIMENT CONTROL LOG AS SHOWN AND AS DIRECTED BY ENGINEER IN FIELD. EROSION FENCE AND SEDIMENT CONTROL LOG TO BE REMOVED BY CONTRACTOR AFTER PERMANENT VEGETATION HAS BEEN ESTABLISHED.
 - 2) THE CONTRACTOR SHALL PLACE STORM SEWER STRUCTURE PROTECTION AT CATCH BASINS AS DIRECTED BY ENGINEER TO PREVENT SEDIMENT FROM ENTERING THE STORM SEWER DURING CONSTRUCTION.
 - 3) THE CONTRACTOR SHALL CONSTRUCT AND MAINTAIN ROCK ENTRANCES AT POINTS OF EXIT FROM PAVEMENT AS DIRECTED BY ENGINEER.
- FOR MORE EROSION CONTROL NOTES SEE GENERAL NOTES – SHEET 7

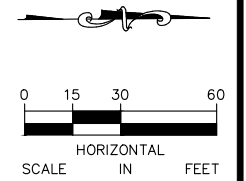

No.	Date	Revisions	App.	DRAWING NAME
				2024_PaveRehab_REM.dwg
				DESIGNED BY: MAK
				DRAWN BY: RCH
				CHECKED BY: MAK
				DATE: 02/29/2024
				PROJECT NO. 24-01

Kimley»Horn

11995 SINGLETREE LANE, SUITE 225, EDEN PRAIRIE, MN 55344
 PHONE: 612-315-1272
 WWW.KIMLEY-HORN.COM

I HEREBY CERTIFY THAT THIS PLAN, SPECIFICATION OR REPORT WAS PREPARED BY ME OR UNDER MY DIRECT SUPERVISION AND THAT I AM A DULY LICENSED PROFESSIONAL ENGINEER UNDER THE LAWS OF THE STATE OF MINNESOTA.

Michael A. Kirsch
 MICHAEL A. KIRSCH
 DATE: 02/29/2024 MN LIC. NO. 59057



CITY OF CHANHASSEN 2024 CITY PAVEMENT REHABILITATION PROJECT	CITY PROJECT 24-01	SHEET NO.
		60
REMOVAL AND EROSION CONTROL PLANS HURON AVENUE STA. 260+50 TO STA. 266+50		188

K:\TOW_Civil\City\CHANHASSEN\2024_CITY STREET REHAB-RECONSTRUCT\CAD\Plan Sheets\2024_PaveRehab_REM.dwg February 29, 2024 - 6:59pm

MATCH LINE 280+50

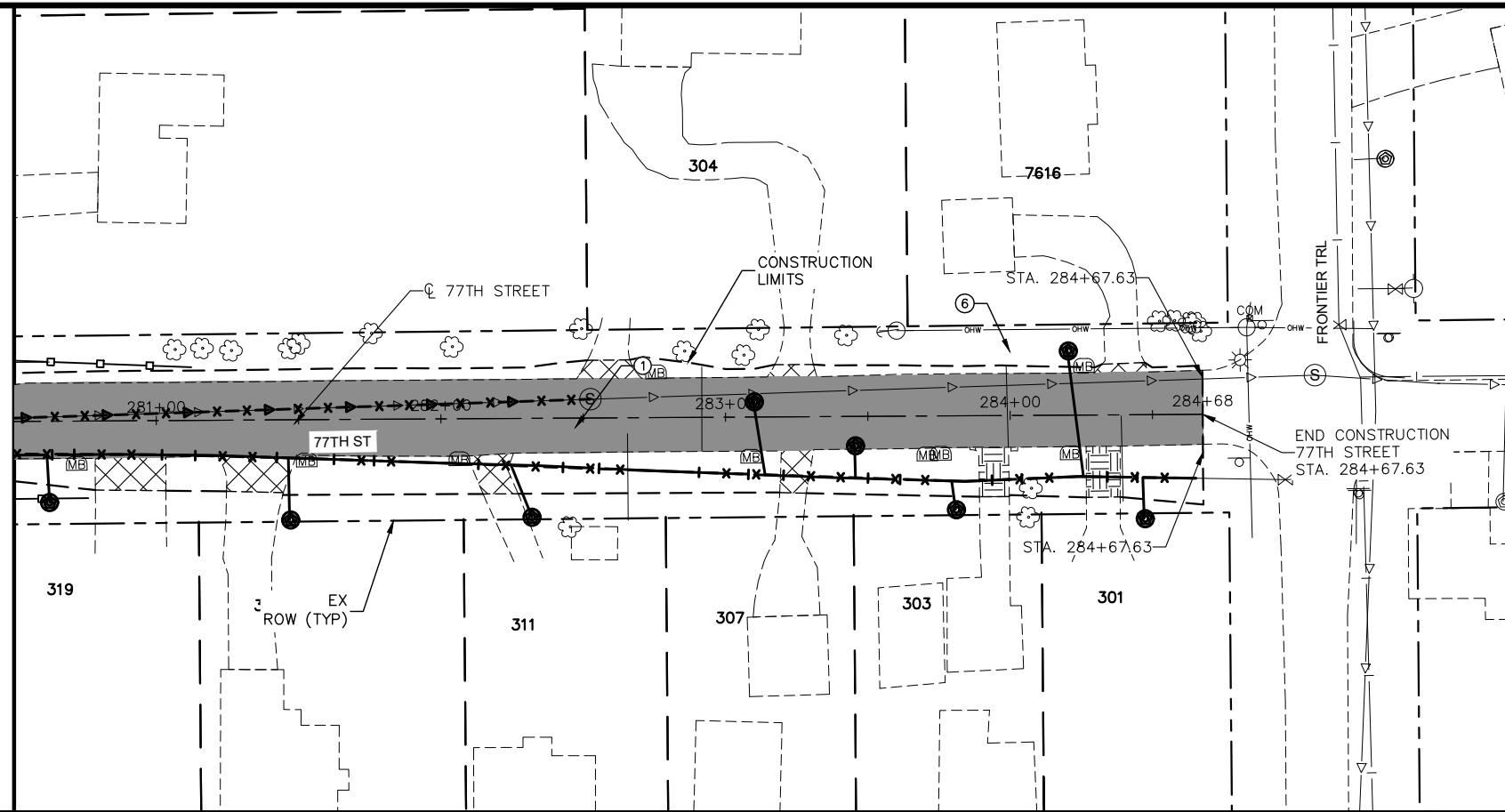

LEGEND:

	2" BITUMINOUS MILL & OVERLAY
	FULL DEPTH RECLAMATION
	REMOVE FULL DEPTH
	REMOVE CONCRETE SIDEWALK
	REMOVE BITUMINOUS TRAIL
	REMOVE CONCRETE DRIVEWAY
	REMOVE BITUMINOUS DRIVEWAY
	REMOVE PAVER DRIVEWAY
	ROCK CONSTRUCTION ENTRANCE
	FULL DEPTH SAW CUT
	CONSTRUCTION LIMITS
	REMOVE CURB & GUTTER
	EXISTING RIGHT-OF-WAY
	REMOVE STORM SEWER PIPE
	REMOVE SANITARY SEWER PIPE
	REMOVE WATERMAIN PIPE
	CLEAR/GRUBB TREE
	PROTECT TREE
	STORM SEWER STRUCTURE PROTECTION
	SILT FENCE

- SPECIFIC NOTES:**
- ① REMOVE SANITARY SEWER MANHOLE
 - ② REMOVE DRAINAGE STRUCTURE
 - ③ ADJUST FRAME AND RINGS
 - ④ REMOVE HYDRANT
 - ⑤ REMOVE SIGN
 - ⑥ EXISTING SPRINKLER SYSTEM – PROTECT IF POSSIBLE
 - ⑦ EXISTING INVISIBLE PET FENCE – PROTECT IF POSSIBLE
 - ⑧ SALVAGE SIGN
 - ⑨ REMOVE GATE VALVE & BOX

- REMOVAL NOTES:**
- 1) STRIP, STOCKPILE AND REUSE INPLACE TOPSOIL IN AREAS TO BE DISTURBED BY CONSTRUCTION.
 - 2) CONTRACTOR SHALL CALL GOPHER STATE ONE CALL AT 651-454-0002. ALL UTILITIES MUST BE LOCATED PRIOR TO THE START OF CONSTRUCTION.
 - 3) SEE UTILITY PLANS AND DRAINAGE PLANS FOR UTILITY ADJUSTMENTS AND REPLACEMENTS
 - 4) CONTRACTOR SHALL PROTECT ALL EXISTING UTILITY STRUCTURES THAT ARE NOT BEING REMOVED OR RELOCATED.
 - 5) TRENCH BOXES OR OTHER TRENCH STABILIZATION METHODS MAY BE REQUIRED DURING CONSTRUCTION TO MINIMIZE REMOVAL LIMITS.
 - 6) CONTRACTOR TO VERIFY REMOVAL LIMITS WITH ENGINEER PRIOR TO SAWCUTTING.
 - 7) ENGINEER TO IDENTIFY AND MARK CONCRETE CURB AND GUTTER REMOVAL LOCATIONS.
 - 8) ENGINEER TO IDENTIFY AND MARK CONCRETE AND BITUMINOUS DRIVEWAYS REMOVAL LOCATIONS.
 - 9) ENGINEER TO IDENTIFY AND MARK CONCRETE WALK REMOVAL LOCATIONS.
 - 10) COORDINATE WITH POSTAL PATRONS AND LOCAL POSTAL AUTHORITY TO RELOCATE MAILBOXES DURING CONSTRUCTION.
 - 11) SEE UTILITY PLAN, SHEETS 68-87 FOR REPAIRS AND REPLACEMENT OF SANITARY SEWER AND WATERMAIN.
 - 12) CONTRACTOR SHALL BE RESPONSIBLE FOR LOCATING, PROTECTING, SUPPORTING IRRIGATION AND SHALL TAKE ALL REASONABLE EFFORTS TO PROTECT IRRIGATION SYSTEMS WITHIN THE PROJECT AREA.
 - 13) INVISIBLE DOG FENCES THAT ARE HIT SHALL BE TEMPORARILY RECONNECTED AS SOON AS POSSIBLE AFTER WORK IS COMPLETE IN THAT IMMEDIATE AREA, AND NO LONGER THAN 24 HRS. CONSTRUCTION MANAGER TO BE NOTIFIED WHEN A DOG FENCE HAS BEEN HIT (INCIDENTAL). CONTRACTOR MUST NOTIFY HOME OWNER IMMEDIATELY AFTER DOG FENCE IS HIT. (INCIDENTAL) DOG FENCE REPAIR WILL ONLY BE PAID ONCE PER ADDRESS.

- EROSION CONTROL NOTES:**
- 1) THE CONTRACTOR SHALL INSTALL AND MAINTAIN EROSION CONTROL FENCE AND SEDIMENT CONTROL LOG AS SHOWN AND AS DIRECTED BY ENGINEER IN FIELD. EROSION FENCE AND SEDIMENT CONTROL LOG TO BE REMOVED BY CONTRACTOR AFTER PERMANENT VEGETATION HAS BEEN ESTABLISHED.
 - 2) THE CONTRACTOR SHALL PLACE STORM SEWER STRUCTURE PROTECTION AT CATCH BASINS AS DIRECTED BY ENGINEER TO PREVENT SEDIMENT FROM ENTERING THE STORM SEWER DURING CONSTRUCTION.
 - 3) THE CONTRACTOR SHALL CONSTRUCT AND MAINTAIN ROCK ENTRANCES AT POINTS OF EXIT FROM PAVEMENT AS DIRECTED BY ENGINEER.
- FOR MORE EROSION CONTROL NOTES SEE GENERAL NOTES – SHEET 7

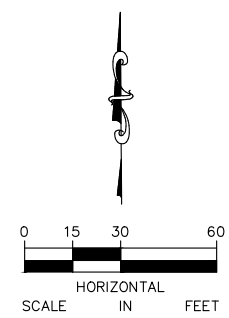

No.	Date	Revisions	App.	DRAWING NAME
				2024_PaveRehab_REM.dwg
				DESIGNED BY: MAK
				DRAWN BY: RCH
				CHECKED BY: MAK
				DATE: 02/29/2024
				PROJECT NO. 24-01

Kimley»Horn

11995 SINGLETREE LANE, SUITE 225, EDEN PRAIRIE, MN 55344
 PHONE: 612-315-1272
 WWW.KIMLEY-HORN.COM

I HEREBY CERTIFY THAT THIS PLAN, SPECIFICATION OR REPORT WAS PREPARED BY ME OR UNDER MY DIRECT SUPERVISION AND THAT I AM A DULY LICENSED PROFESSIONAL ENGINEER UNDER THE LAWS OF THE STATE OF MINNESOTA.

Michael A. Kirsch
 MICHAEL A. KIRSCH
 DATE: 02/29/2024 MN LIC. NO. 59057



CITY OF CHANHASSEN
 2024 CITY PAVEMENT
 REHABILITATION PROJECT

REMOVAL AND EROSION CONTROL PLANS
 77TH STREET
 STA. 280+50 TO STA. 284+68

CITY PROJECT	24-01	SHEET NO.
		61
		188

k:\TCW\Civil\City\CHANHASSEN\2024 CITY STREET REHAB-RECONSTRUCT\CAD\Plan Sheets\2024_PaveRehab_PSTRM.dwg March 01, 2024 - 10:18am

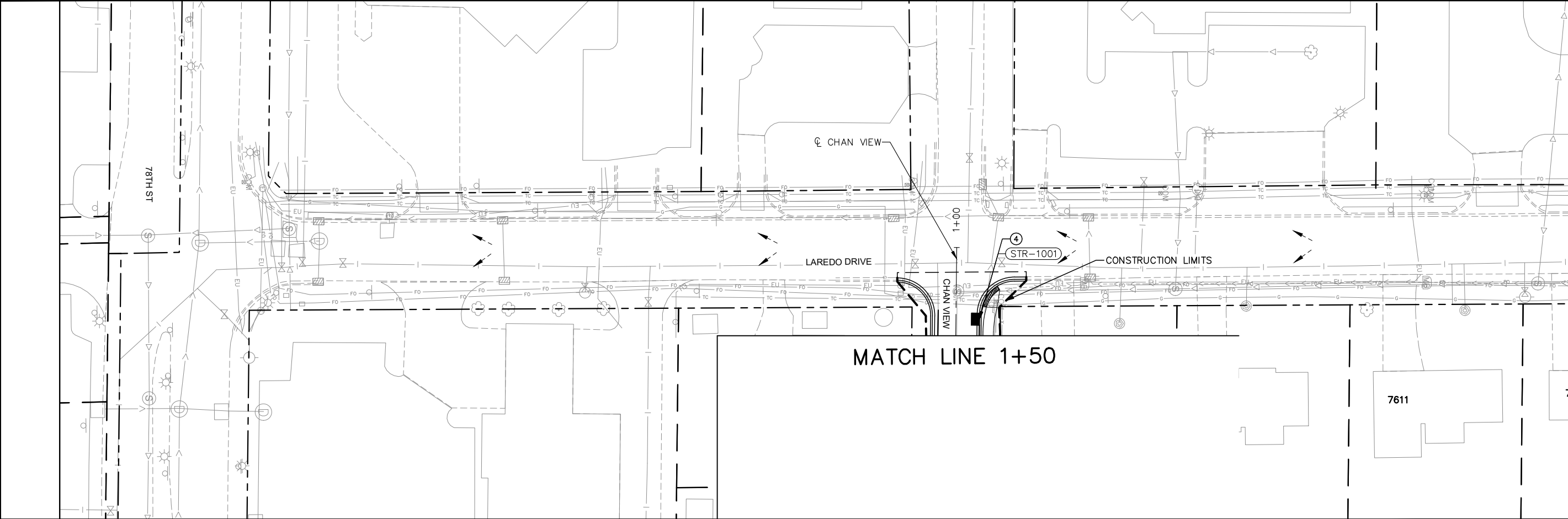

MATCH LINE
SEE NEXT SHEET

- LEGEND:**
- (STR-XXX) STRUCTURE NUMBER
 - PROPOSED STORM SEWER
 - - - - - PROPOSED DRAIN TILE
 - ● ○ ► PROPOSED DRAINAGE STRUCTURE
 - EXISTING STORM SEWER
 - - - - - SURFACE FLOW DIRECTION

1. SEE SHEETS 108 - 110 FOR STORM SEWER LATERAL PROFILES

- SPECIFIC NOTES:**
- ① GROUT DRAINAGE STRUCTURE
 - ② REPLACE CASTING AND ADJUST TO GRADE
 - ③ SUMP PUMP DISCHARGE CONNECTION PER CITY PLATE 5236
 - ④ CONNECT TO EXISTING STORM SEWER
 - ⑤ CONNECT INTO EXISTING DRAINAGE STRUCTURE
 - ⑥ INSTALL RIP RAP PER CITY PLATE 3107

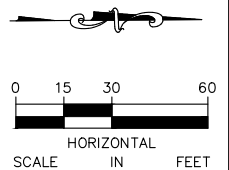

No.	Date	Revisions	App.

DRAWING NAME	2024_PaveRehab_PSTRM.dwg
DESIGNED BY:	WAS
DRAWN BY:	WAS
CHECKED BY:	ART
DATE:	02/29/2024
PROJECT NO.	24-01

Kimley»Horn

11995 SINGLETREE LANE, SUITE 225, EDEN PRAIRIE, MN 55344
 PHONE: 612-315-1272
 WWW.KIMLEY-HORN.COM

I HEREBY CERTIFY THAT THIS PLAN, SPECIFICATION OR REPORT WAS PREPARED BY ME OR UNDER MY DIRECT SUPERVISION AND THAT I AM A DULY LICENSED PROFESSIONAL ENGINEER UNDER THE LAWS OF THE STATE OF MINNESOTA.

Adam R. Joaden
 ADAM R. JOADEN
 DATE: 02/29/2024 LIC. NO. 59337



CITY OF CHANHASSEN
 2024 CITY PAVEMENT REHABILITATION PROJECT

DRAINAGE PLAN & PROFILE
 LAREDO DRIVE

CITY PROJECT	24-01
SHEET NO.	88

188

k:\TOW_Civil\City\CHANHASSEN\2024 CITY STREET REHAB-RECONSTRUCT\Plan Sheets\2024_PaveRehab_PSTRM.dwg March 01, 2024 - 10:18am

MATCH LINE
SEE PREVIOUS SHEET

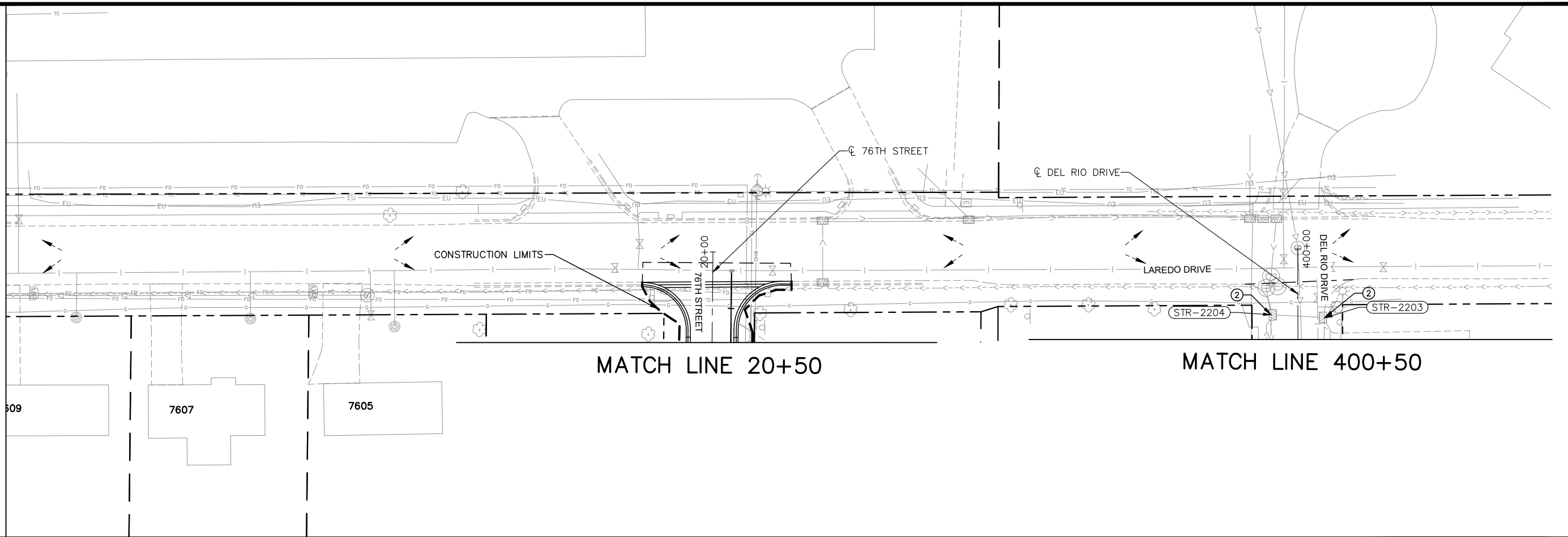

LEGEND:

- (STR-XXX) STRUCTURE NUMBER
- > PROPOSED STORM SEWER
- -> PROPOSED DRAIN TILE
- ○ ▶ PROPOSED DRAINAGE STRUCTURE
- -> EXISTING STORM SEWER
- -> SURFACE FLOW DIRECTION

GENERAL NOTES:

1. SEE SHEETS 108 - 110 FOR STORM SEWER LATERAL PROFILES

SPECIFIC NOTES:

- ① GROUT DRAINAGE STRUCTURE
- ② REPLACE CASTING AND ADJUST TO GRADE
- ③ SUMP PUMP DISCHARGE CONNECTION PER CITY PLATE 5236
- ④ CONNECT TO EXISTING STORM SEWER
- ⑤ CONNECT INTO EXISTING DRAINAGE STRUCTURE
- ⑥ INSTALL RIP RAP PER CITY PLATE 3107

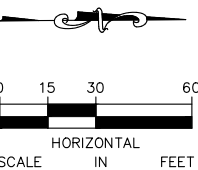

No.	Date	Revisions	App.

DRAWING NAME	
DESIGNED BY:	WAS
DRAWN BY:	WAS
CHECKED BY:	ART
DATE:	02/29/2024
PROJECT NO.	24-01

Kimley»Horn

11995 SINGLETREE LANE, SUITE 225, EDEN PRAIRIE, MN 55344
 PHONE: 612-315-1272
 WWW.KIMLEY-HORN.COM

I HEREBY CERTIFY THAT THIS PLAN, SPECIFICATION OR REPORT WAS PREPARED BY ME OR UNDER MY DIRECT SUPERVISION AND THAT I AM A DULY LICENSED PROFESSIONAL ENGINEER UNDER THE LAWS OF THE STATE OF MINNESOTA.

Adam R. Joaden
 ADAM R. JOADEN
 DATE: 02/29/2024 LIC. NO. 59337



CITY OF CHANHASSEN
 2024 CITY PAVEMENT REHABILITATION PROJECT

DRAINAGE PLAN & PROFILE
 LAREDO DRIVE

CITY PROJECT	24-01
SHEET NO.	89

188

MATCH LINE SHEET 400+50

MATCH LINE 453+50

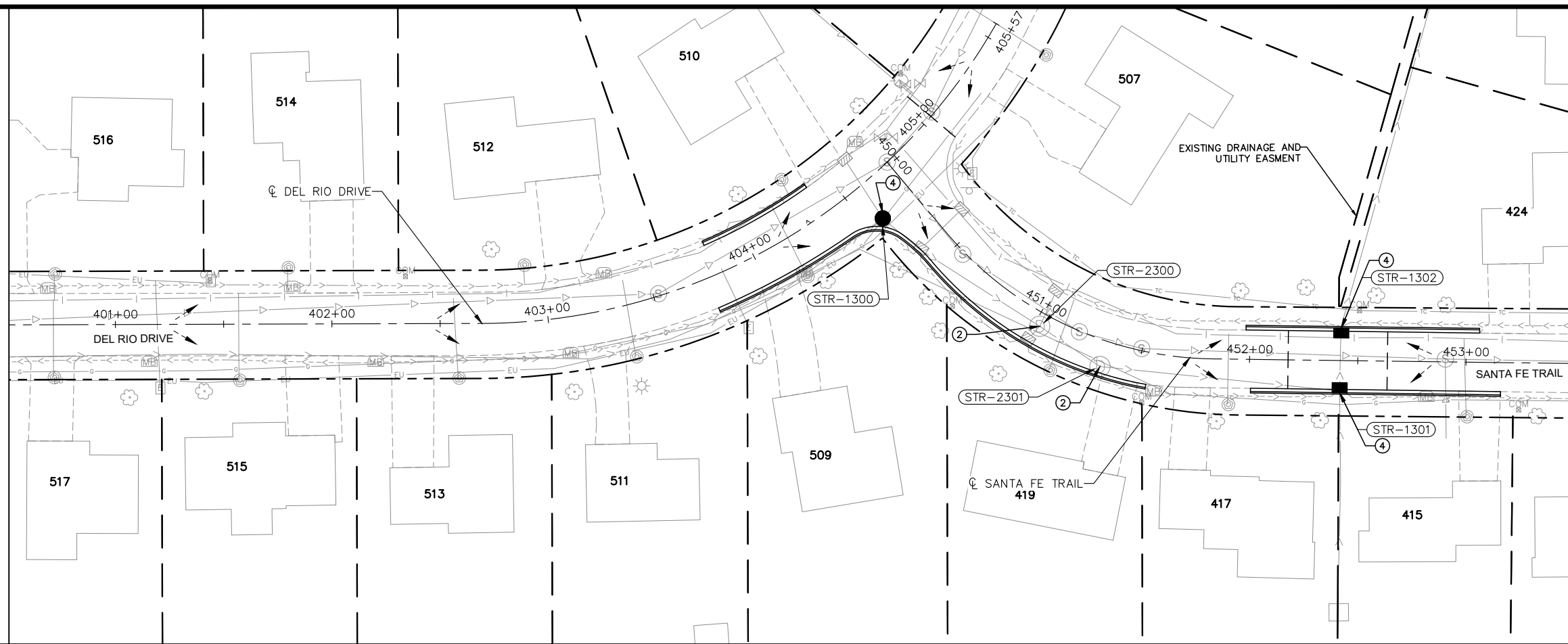

LEGEND:

- (STR-XXX) STRUCTURE NUMBER
- > PROPOSED STORM SEWER
- -> PROPOSED DRAIN TILE
- ● ○ ▶ PROPOSED DRAINAGE STRUCTURE
- > EXISTING STORM SEWER
- -> SURFACE FLOW DIRECTION

GENERAL NOTES:

1. SEE SHEETS 108 - 110 FOR STORM SEWER LATERAL PROFILES

SPECIFIC NOTES:

- ① GROUT DRAINAGE STRUCTURE
- ② REPLACE CASTING AND ADJUST TO GRADE
- ③ SUMP PUMP DISCHARGE CONNECTION PER CITY PLATE 5236
- ④ CONNECT TO EXISTING STORM SEWER
- ⑤ CONNECT INTO EXISTING DRAINAGE STRUCTURE
- ⑥ INSTALL RIP RAP PER CITY PLATE 3107

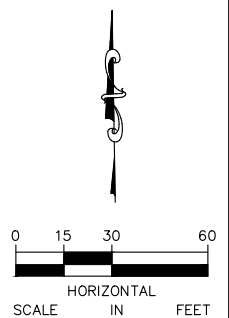

k:\TOW_Civil\City\CHANHASSEN\2024 CITY STREET REHAB-RECONSTRUCT\Plan Sheets\2024_PaveRehab_PSTRM.dwg March 01, 2024 - 10:18am

No.	Date	Revisions	App.

DRAWING NAME	2024_PaveRehab_PSTRM.dwg
DESIGNED BY:	WAS
DRAWN BY:	WAS
CHECKED BY:	ART
DATE:	02/29/2024
PROJECT NO.	24-01

Kimley»Horn

11995 SINGLETREE LANE, SUITE 225, EDEN PRAIRIE, MN 55344
PHONE: 612-315-1272
WWW.KIMLEY-HORN.COM

I HEREBY CERTIFY THAT THIS PLAN, SPECIFICATION OR REPORT WAS PREPARED BY ME OR UNDER MY DIRECT SUPERVISION AND THAT I AM A DULY LICENSED PROFESSIONAL ENGINEER UNDER THE LAWS OF THE STATE OF MINNESOTA.

Adam R. Joaden
ADAM R. JOADEN
DATE: 02/29/2024 LIC. NO. 59337



CITY OF CHANHASSEN
2024 CITY PAVEMENT
REHABILITATION PROJECT

DRAINAGE PLAN & PROFILE
DEL RIO DR AND SANTA FE TRAIL
STA. 400+50 TO STA. 543+50

CITY PROJECT	24-01
SHEET NO.	90

188

k:\TOW_Civil\City\CHANHASSEN\2024 CITY STREET REHAB-RECONSTRUCT\Plan Sheets\2024_PaveRehab_PSTRM.dwg March 01, 2024 - 2:11pm

MATCH LINE 543+50

MATCH LINE SHEET 314+50

- LEGEND:**
- (STR-XXX) STRUCTURE NUMBER
 - > PROPOSED STORM SEWER
 - - -> PROPOSED DRAIN TILE
 - ● ○ ▶ PROPOSED DRAINAGE STRUCTURE
 - > EXISTING STORM SEWER
 - -> SURFACE FLOW DIRECTION

- GENERAL NOTES:**
1. SEE SHEETS 108 - 110 FOR STORM SEWER LATERAL PROFILES

- SPECIFIC NOTES:**
- ① GROUT DRAINAGE STRUCTURE
 - ② REPLACE CASTING AND ADJUST TO GRADE
 - ③ SUMP PUMP DISCHARGE CONNECTION PER CITY PLATE 5236
 - ④ CONNECT TO EXISTING STORM SEWER
 - ⑤ CONNECT INTO EXISTING DRAINAGE STRUCTURE
 - ⑥ INSTALL RIP RAP PER CITY PLATE 3107

No.	Date	Revisions	App.

DRAWING NAME	2024_PaveRehab_PSTRM.dwg
DESIGNED BY:	WAS
DRAWN BY:	WAS
CHECKED BY:	ART
DATE:	02/29/2024
PROJECT NO.	24-01

Kimley»Horn

11995 SINGLETREE LANE, SUITE 225, EDEN PRAIRIE, MN 55344
 PHONE: 612-315-1272
 WWW.KIMLEY-HORN.COM

I HEREBY CERTIFY THAT THIS PLAN, SPECIFICATION OR REPORT WAS PREPARED BY ME OR UNDER MY DIRECT SUPERVISION AND THAT I AM A DULY LICENSED PROFESSIONAL ENGINEER UNDER THE LAWS OF THE STATE OF MINNESOTA.

Adam R. Joaden
 ADAM R. JOADEN
 DATE: 02/29/2024 LIC. NO. 59337



CITY OF CHANHASSEN
 2024 CITY PAVEMENT
 REHABILITATION PROJECT

DRAINAGE PLAN & PROFILE
 DEL RIO DR AND SANTA FE TRAIL
 STA. 543+50 TO STA. 459+14

CITY PROJECT 24-01

SHEET NO. 91

188

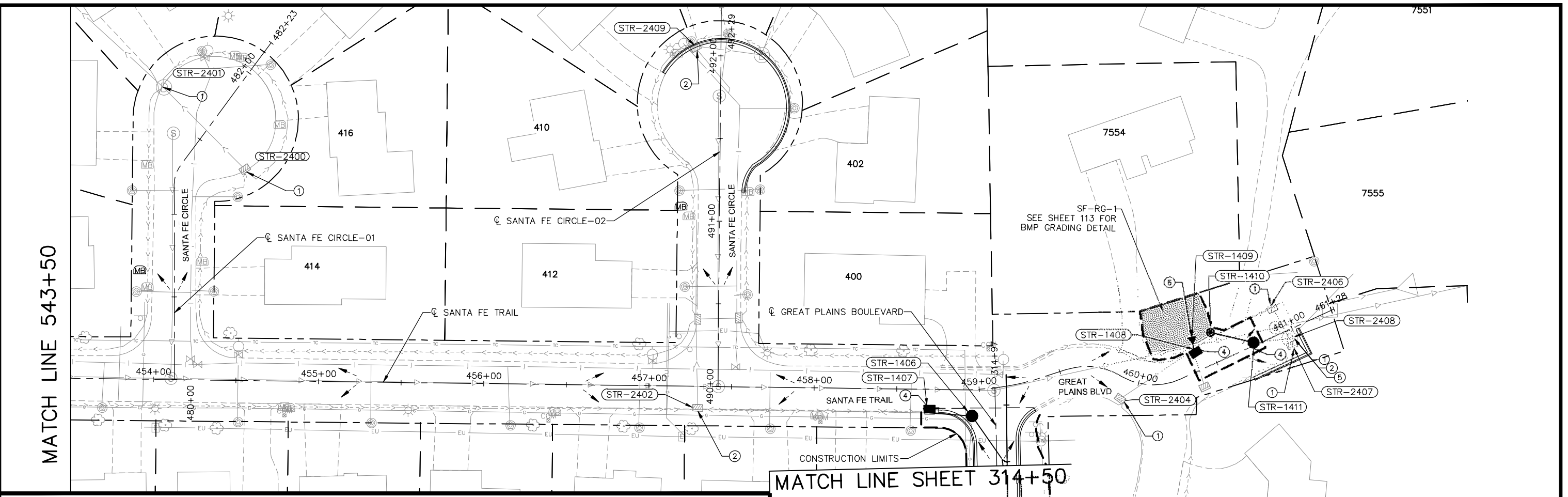
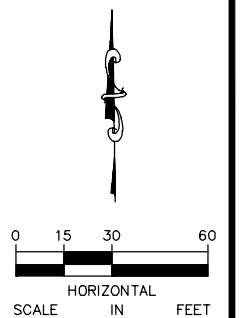

k:\TOW_Civil\City\CHANHASSEN\2024 CITY STREET REHAB-RECON\CAD\Plan Sheets\2024_PaveRehab_PSTRM.dwg March 01, 2024 - 2:16pm

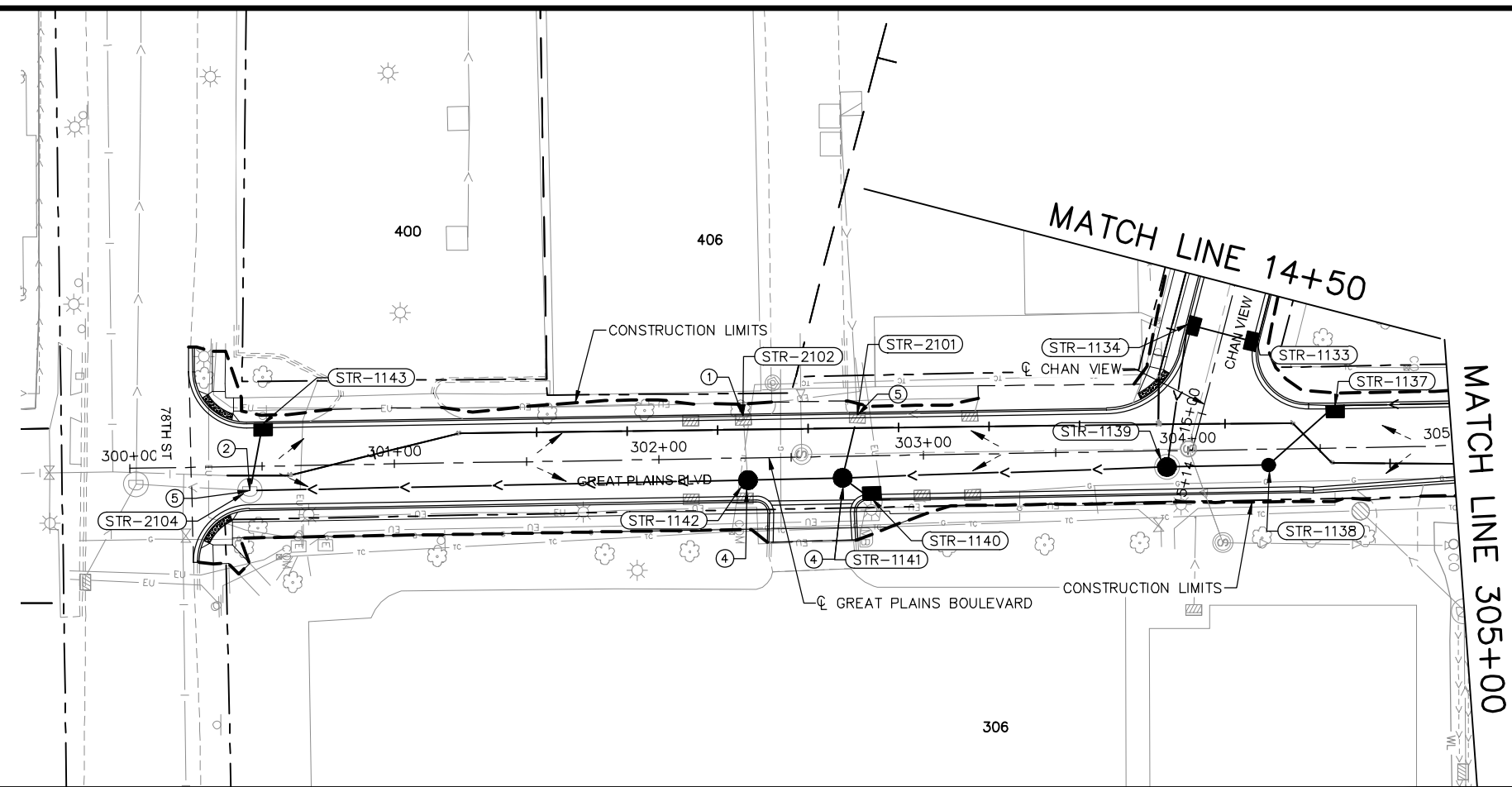

- LEGEND:**
- (STR-XXX) STRUCTURE NUMBER
 - >— PROPOSED STORM SEWER
 - - - - - PROPOSED DRAIN TILE
 - ● ○ ▶ PROPOSED DRAINAGE STRUCTURE
 - >— EXISTING STORM SEWER
 - - - - - SURFACE FLOW DIRECTION

- GENERAL NOTES:**
1. SEE SHEETS 108 - 110 FOR STORM SEWER LATERAL PROFILES

- SPECIFIC NOTES:**
- ① GROUT DRAINAGE STRUCTURE
 - ② REPLACE CASTING AND ADJUST TO GRADE
 - ③ SUMP PUMP DISCHARGE CONNECTION PER CITY PLATE 5236
 - ④ CONNECT TO EXISTING STORM SEWER
 - ⑤ CONNECT INTO EXISTING DRAINAGE STRUCTURE
 - ⑥ INSTALL RIP RAP PER CITY PLATE 3107

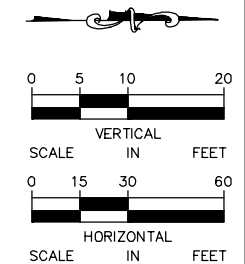
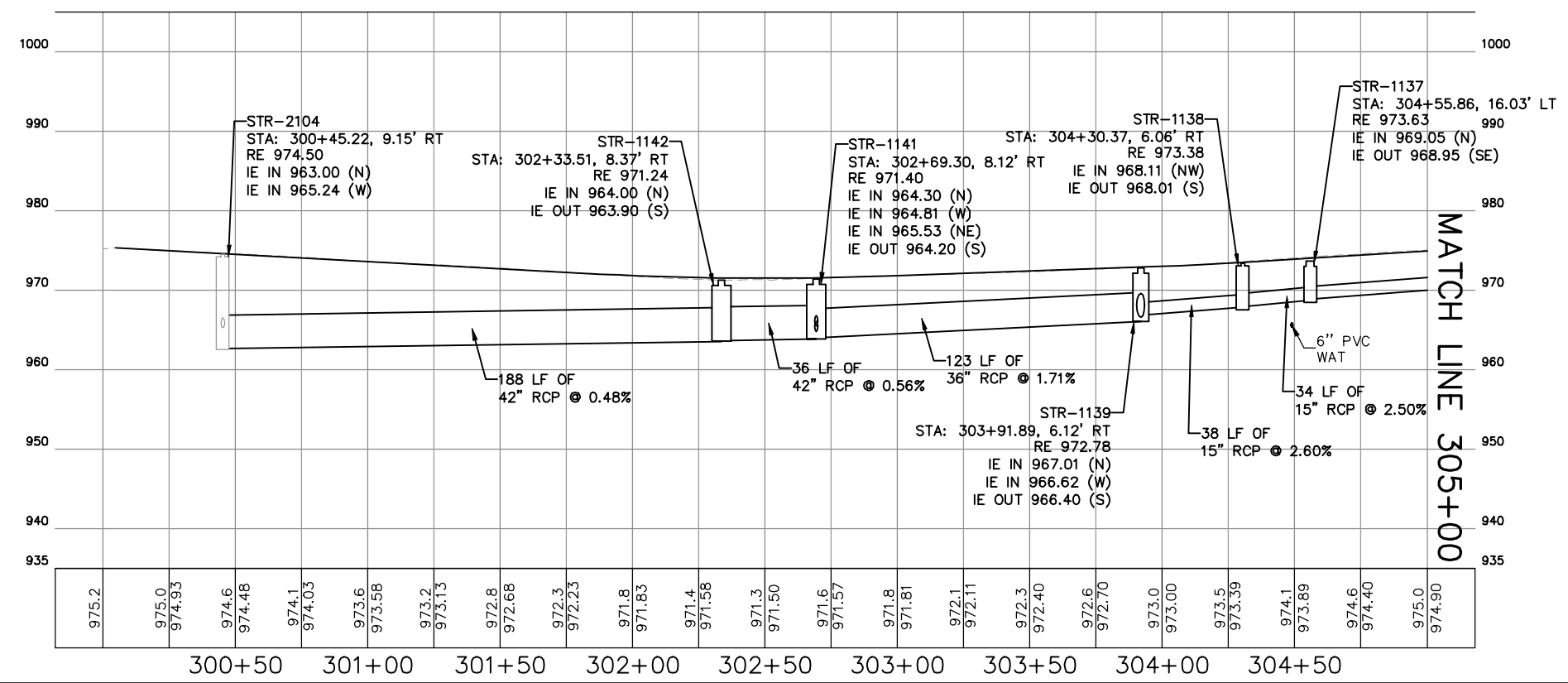

No.	Date	Revisions

App.	DRAWING NAME
	2024_PaveRehab_PSTRM.dwg
	DESIGNED BY: WAS
	DRAWN BY: WAS
	CHECKED BY: ART
	DATE: 02/29/2024
	PROJECT NO. 24-01

Kimley»Horn

11995 SINGLETREE LANE, SUITE 225, EDEN PRAIRIE, MN 55344
 PHONE: 612-315-1272
 WWW.KIMLEY-HORN.COM

I HEREBY CERTIFY THAT THIS PLAN, SPECIFICATION OR REPORT WAS PREPARED BY ME OR UNDER MY DIRECT SUPERVISION AND THAT I AM A DULY LICENSED PROFESSIONAL ENGINEER UNDER THE LAWS OF THE STATE OF MINNESOTA.

Adam R. Joaden
 ADAM R. JOADEN
 DATE: 02/29/2024 LIC. NO. 59057



CITY OF CHANHASSEN
 2024 CITY PAVEMENT
 REHABILITATION PROJECT

DRAINAGE PLAN & PROFILE
 GREAT PLAINS BOULEVARD
 STA. 300+00 TO STA. 305+00

CITY PROJECT 24-01

SHEET NO. 92

188

k:\TOW_Civil\City\CHANHASSEN\2024 CITY STREET REHAB-RECON\ST\CAD\Plan Sheets\2024_PaveRehab_PSTRM.dwg March 01, 2024 - 10:18am

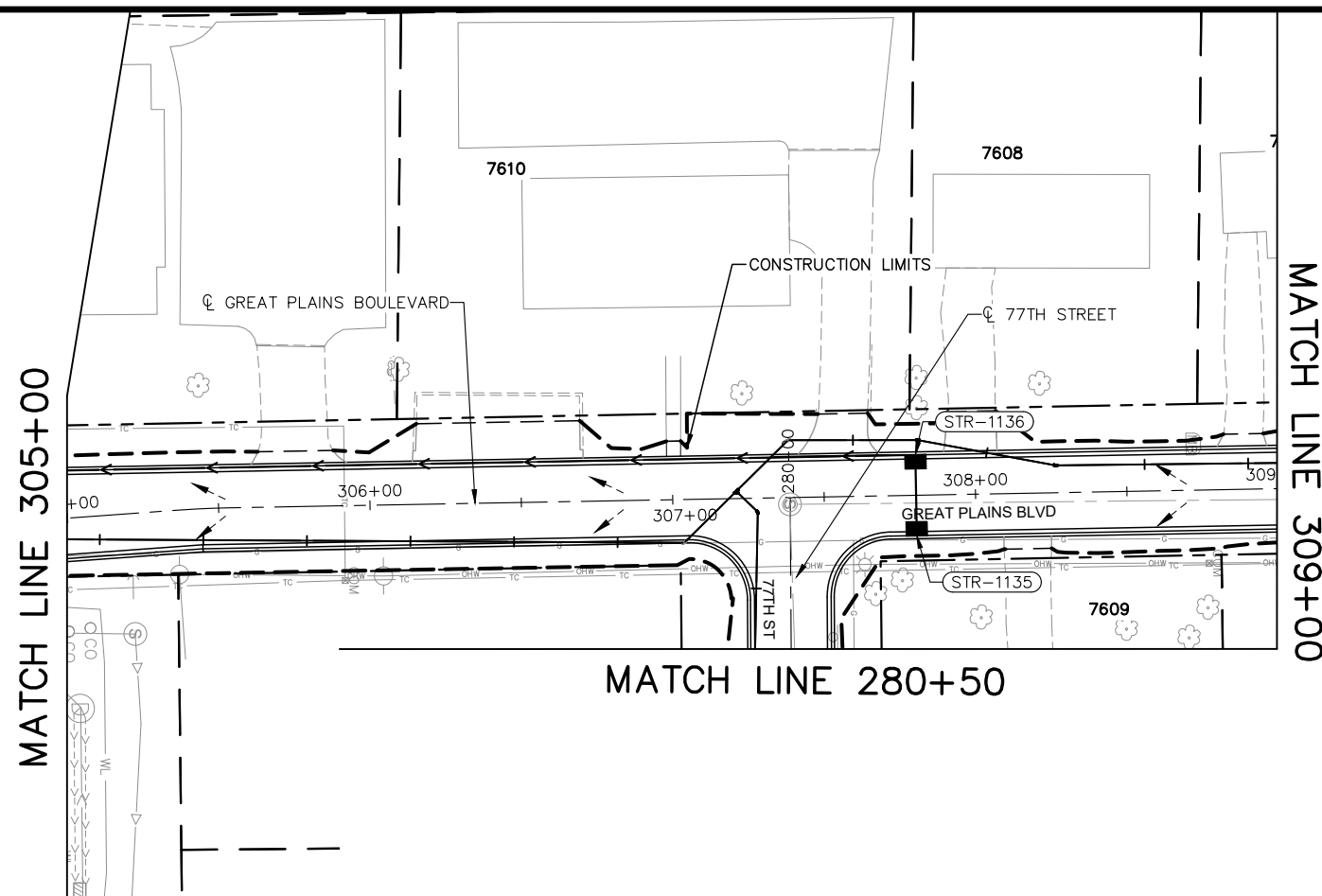

LEGEND:

- (STR-XXX) STRUCTURE NUMBER
- >— PROPOSED STORM SEWER
- - - - - PROPOSED DRAIN TILE
- ● ○ ▶ PROPOSED DRAINAGE STRUCTURE
- >— EXISTING STORM SEWER
- - - - - SURFACE FLOW DIRECTION

GENERAL NOTES:

1. SEE SHEETS 108 - 110 FOR STORM SEWER LATERAL PROFILES

SPECIFIC NOTES:

- ① GROUT DRAINAGE STRUCTURE
- ② REPLACE CASTING AND ADJUST TO GRADE
- ③ SUMP PUMP DISCHARGE CONNECTION PER CITY PLATE 5236
- ④ CONNECT TO EXISTING STORM SEWER
- ⑤ CONNECT INTO EXISTING DRAINAGE STRUCTURE
- ⑥ INSTALL RIP RAP PER CITY PLATE 3107

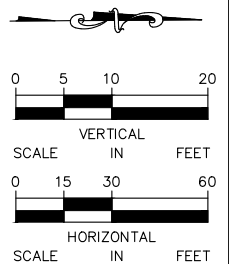
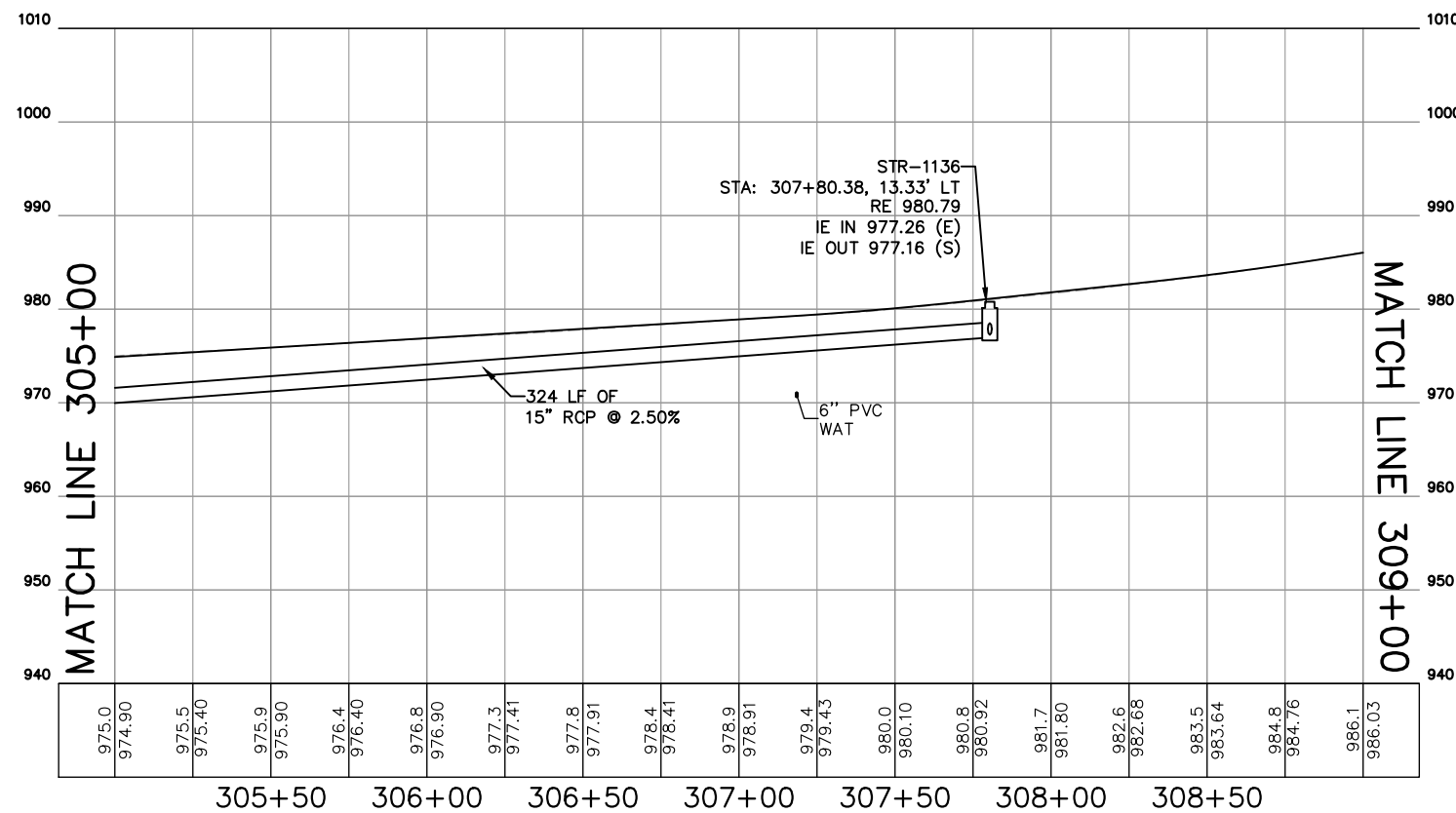

No.	Date	Revisions

App.	DRAWING NAME
	2024_PaveRehab_PSTRM.dwg
	DESIGNED BY: WAS
	DRAWN BY: WAS
	CHECKED BY: ART
	DATE: 02/29/2024
	PROJECT NO. 24-01

Kimley»Horn

11995 SINGLETREE LANE, SUITE 225, EDEN PRAIRIE, MN 55344
 PHONE: 612-315-1272
 WWW.KIMLEY-HORN.COM

I HEREBY CERTIFY THAT THIS PLAN, SPECIFICATION OR REPORT WAS PREPARED BY ME OR UNDER MY DIRECT SUPERVISION AND THAT I AM A DULY LICENSED PROFESSIONAL ENGINEER UNDER THE LAWS OF THE STATE OF MINNESOTA.

Adam R. Ladden
 ADAM R. LADDEN
 DATE: 02/29/2024 LIC. NO. 59337



CITY OF CHANHASSEN
 2024 CITY PAVEMENT
 REHABILITATION PROJECT

DRAINAGE PLAN & PROFILE
 GREAT PLAINS BOULEVARD
 STA. 305+00 TO STA. 309+00

CITY PROJECT	24-01	SHEET NO.	93
			188

k:\TOW_Civil\City\CHANHASSEN\2024 CITY STREET REHAB-RECONSTRUCT\CAD\Plan Sheets\2024_PaveRehab_PSTRM.dwg March 01, 2024 - 2:21pm

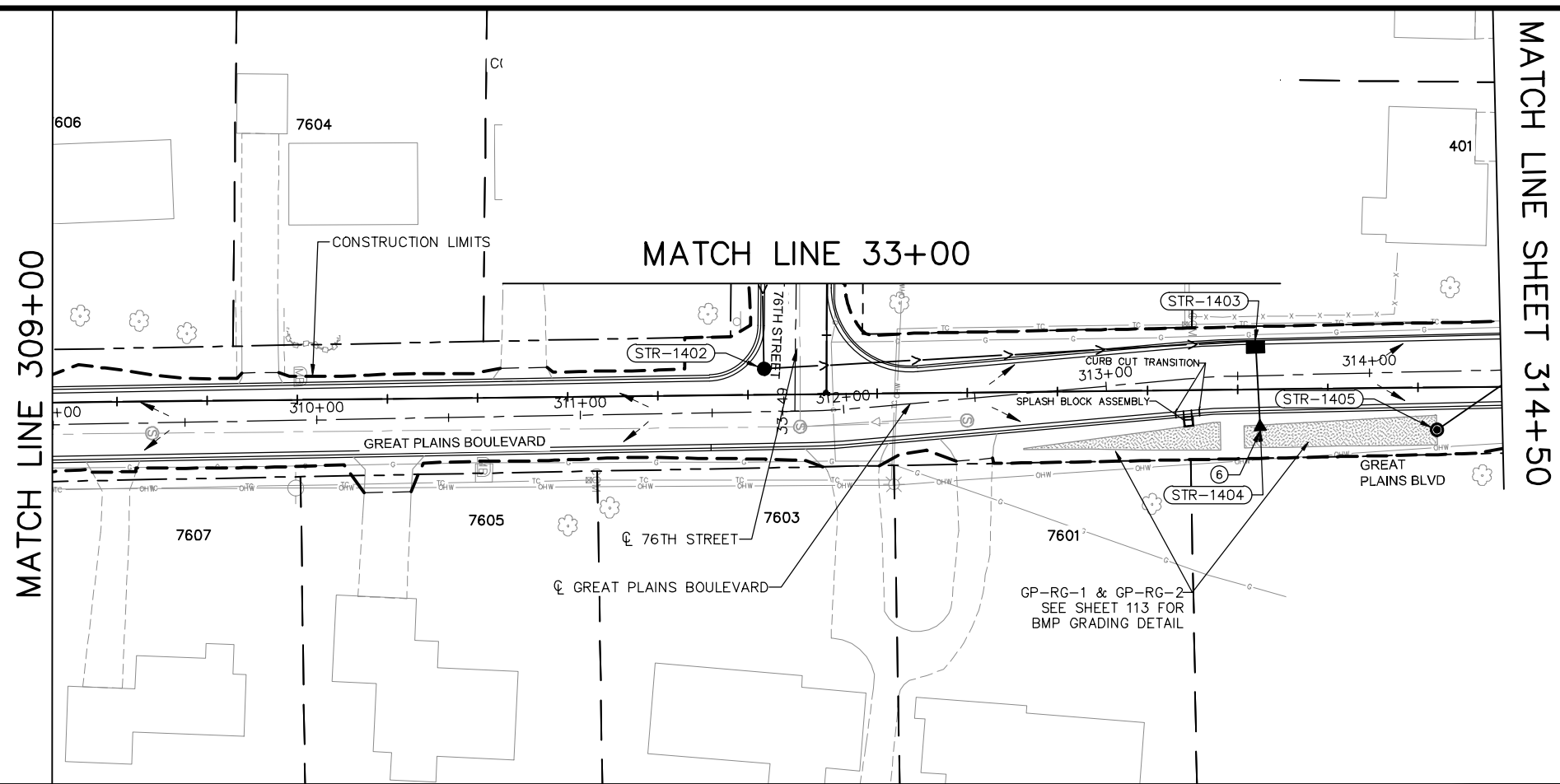

- LEGEND:**
- (STR-XXX) STRUCTURE NUMBER
 - >— PROPOSED STORM SEWER
 - - - - - PROPOSED DRAIN TILE
 - ● ○ ▶ PROPOSED DRAINAGE STRUCTURE
 - >— EXISTING STORM SEWER
 - - - - - SURFACE FLOW DIRECTION

- GENERAL NOTES:**
1. SEE SHEETS 108 - 110 FOR STORM SEWER LATERAL PROFILES

- SPECIFIC NOTES:**
- ① GROUT DRAINAGE STRUCTURE
 - ② REPLACE CASTING AND ADJUST TO GRADE
 - ③ SUMP PUMP DISCHARGE CONNECTION PER CITY PLATE 5236
 - ④ CONNECT TO EXISTING STORM SEWER
 - ⑤ CONNECT INTO EXISTING DRAINAGE STRUCTURE
 - ⑥ INSTALL RIP RAP PER CITY PLATE 3107

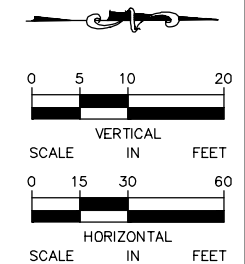
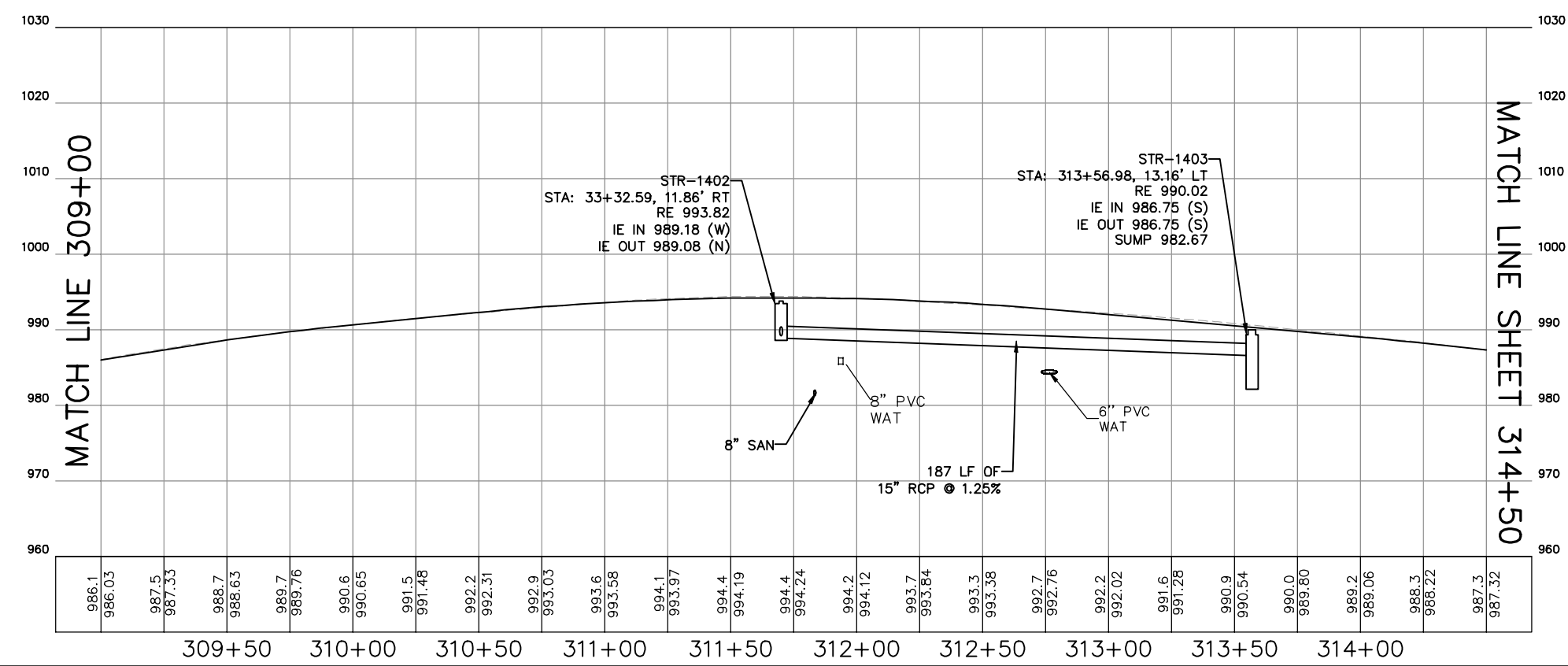

No.	Date	Revisions	App.	DRAWING NAME
				2024_PaveRehab_PSTRM.dwg
				DESIGNED BY: WAS
				DRAWN BY: WAS
				CHECKED BY: ART
				DATE: 02/29/2024
				PROJECT NO. 24-01

Kimley»Horn

11995 SINGLETREE LANE, SUITE 225, EDEN PRAIRIE, MN 55344
 PHONE: 612-315-1272
 WWW.KIMLEY-HORN.COM

I HEREBY CERTIFY THAT THIS PLAN, SPECIFICATION OR REPORT WAS PREPARED BY ME OR UNDER MY DIRECT SUPERVISION AND THAT I AM A DULY LICENSED PROFESSIONAL ENGINEER UNDER THE LAWS OF THE STATE OF MINNESOTA.

Adam R. Joaden
 ADAM R. JOADEN
 DATE: 02/29/2024 M.N. LIC. NO. 59337



CITY OF CHANHASSEN
 2024 CITY PAVEMENT
 REHABILITATION PROJECT

DRAINAGE PLAN & PROFILE
 GREAT PLAINS BOULEVARD
 STA. 309+00 TO STA. 314+50

CITY PROJECT	24-01	SHEET NO.	94
			188

k:\TOW_Civil\City\CHANHASSEN\2024 CITY STREET REHAB-RECON\CAD\Plan Sheets\2024_PaveRehab_PSTRM.dwg March 01, 2024 - 2:24pm

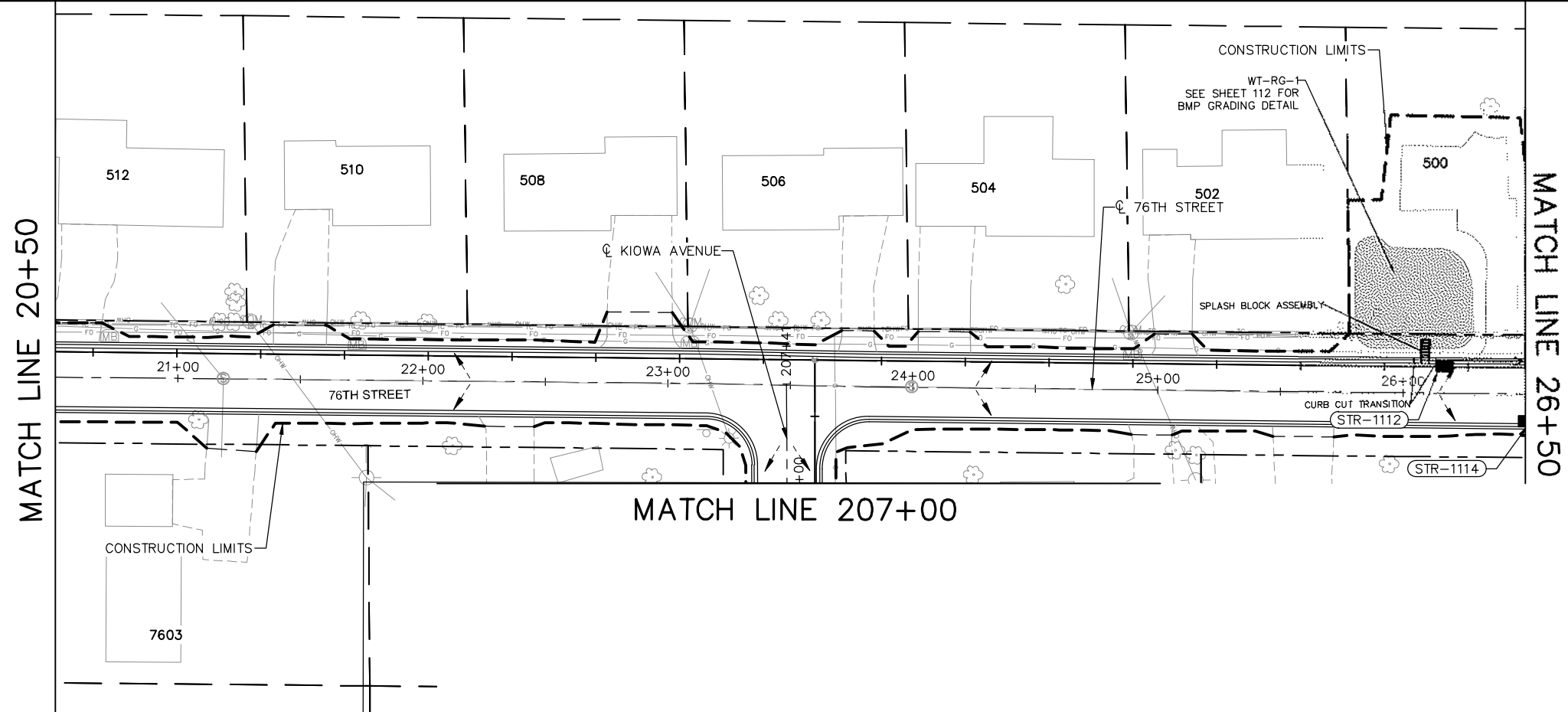

- LEGEND:**
- (STR-XXX) STRUCTURE NUMBER
 - >— PROPOSED STORM SEWER
 - - - - - PROPOSED DRAIN TILE
 - ● ○ ▶ PROPOSED DRAINAGE STRUCTURE
 - >— EXISTING STORM SEWER
 - - - - - SURFACE FLOW DIRECTION

- GENERAL NOTES:**
1. SEE SHEETS 108 - 110 FOR STORM SEWER LATERAL PROFILES

- SPECIFIC NOTES:**
- ① GROUT DRAINAGE STRUCTURE
 - ② REPLACE CASTING AND ADJUST TO GRADE
 - ③ SUMP PUMP DISCHARGE CONNECTION PER CITY PLATE 5236
 - ④ CONNECT TO EXISTING STORM SEWER
 - ⑤ CONNECT INTO EXISTING DRAINAGE STRUCTURE
 - ⑥ INSTALL RIP RAP PER CITY PLATE 3107

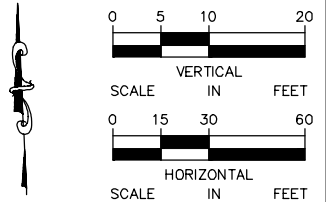
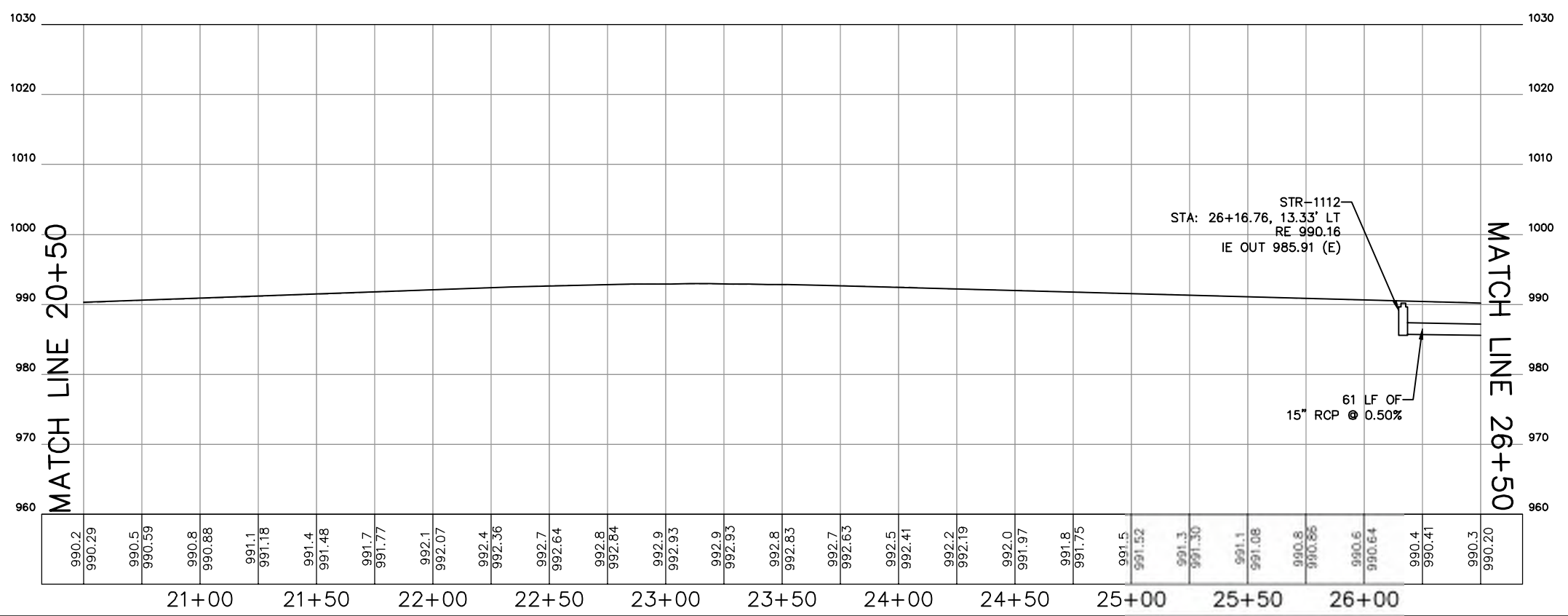

No.	Date	Revisions	App.	DRAWING NAME
				2024_PaveRehab_PSTRM.dwg
				DESIGNED BY: WAS
				DRAWN BY: WAS
				CHECKED BY: ART
				DATE: 02/29/2024
				PROJECT NO. 24-01

Kimley»Horn

11995 SINGLETREE LANE, SUITE 225, EDEN PRAIRIE, MN 55344
 PHONE: 612-315-1272
 WWW.KIMLEY-HORN.COM

I HEREBY CERTIFY THAT THIS PLAN, SPECIFICATION OR REPORT WAS PREPARED BY ME OR UNDER MY DIRECT SUPERVISION AND THAT I AM A DULY LICENSED PROFESSIONAL ENGINEER UNDER THE LAWS OF THE STATE OF MINNESOTA.

Adam R. Loaden
 ADAM R. LOADEN
 DATE: 02/29/2024 MN LIC. NO. 59337



CITY OF CHANHASSEN
 2024 CITY PAVEMENT
 REHABILITATION PROJECT

DRAINAGE PLAN & PROFILE
 76TH STREET
 STA. 20+50 TO STA. 26+50

CITY PROJECT	24-01	SHEET NO.	95
		188	

K:\TOW_Civil\City\CHANHASSEN\2024 CITY STREET REHAB-RECON\CAD\Plan Sheets\2024_PaveRehab_PSTRM.dwg March 01, 2024 - 10:19am

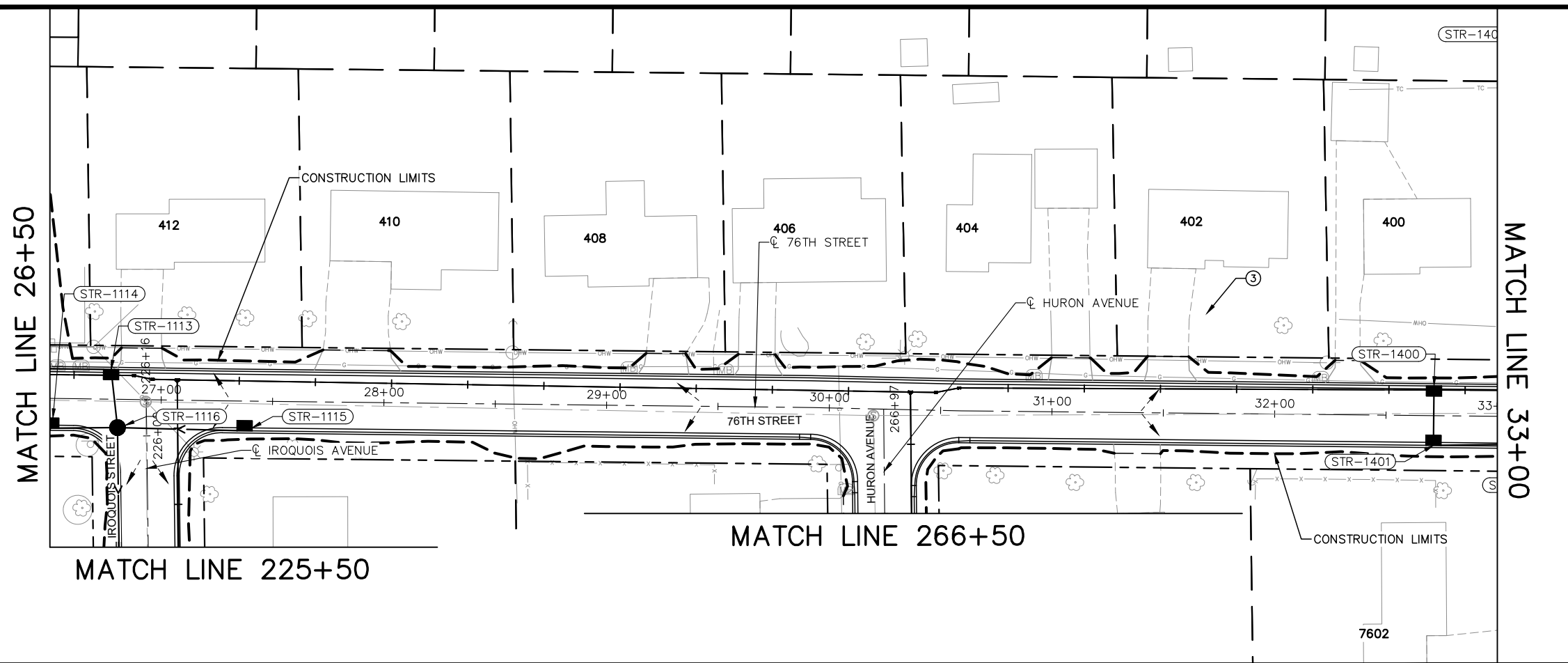

- LEGEND:**
- (STR-XXX) STRUCTURE NUMBER
 - >— PROPOSED STORM SEWER
 - - - - - PROPOSED DRAIN TILE
 - ● ○ ▶ PROPOSED DRAINAGE STRUCTURE
 - >— EXISTING STORM SEWER
 - - - - - SURFACE FLOW DIRECTION

- GENERAL NOTES:**
1. SEE SHEETS 108 - 110 FOR STORM SEWER LATERAL PROFILES

- SPECIFIC NOTES:**
- ① GROUT DRAINAGE STRUCTURE
 - ② REPLACE CASTING AND ADJUST TO GRADE
 - ③ SUMP PUMP DISCHARGE CONNECTION PER CITY PLATE 5236
 - ④ CONNECT TO EXISTING STORM SEWER
 - ⑤ CONNECT INTO EXISTING DRAINAGE STRUCTURE
 - ⑥ INSTALL RIP RAP PER CITY PLATE 3107

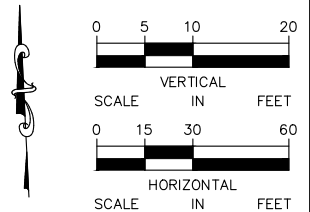
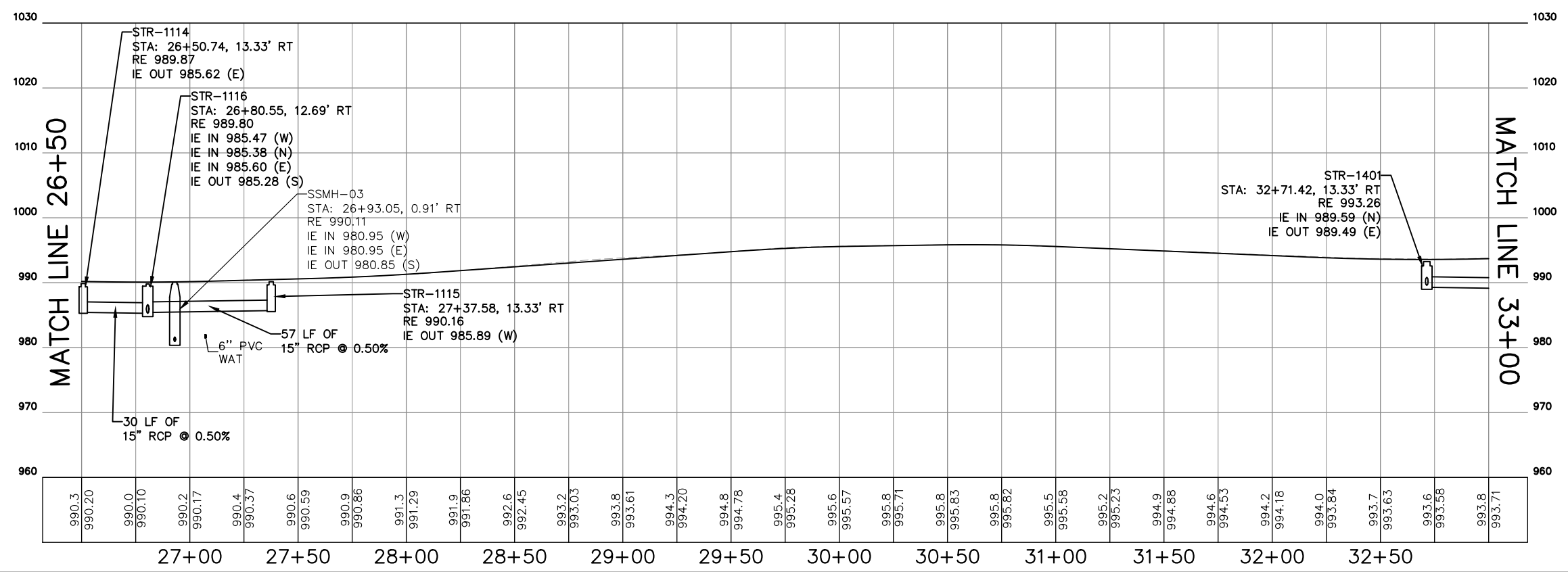

No.	Date	Revisions	App.

DRAWING NAME	2024_PaveRehab_PSTRM.dwg
DESIGNED BY:	WAS
DRAWN BY:	WAS
CHECKED BY:	ART
DATE:	02/29/2024
PROJECT NO.	24-01

Kimley»Horn

11995 SINGLETREE LANE, SUITE 225, EDEN PRAIRIE, MN 55344
 PHONE: 612-315-1272
 WWW.KIMLEY-HORN.COM

I HEREBY CERTIFY THAT THIS PLAN, SPECIFICATION OR REPORT WAS PREPARED BY ME OR UNDER MY DIRECT SUPERVISION AND THAT I AM A DULY LICENSED PROFESSIONAL ENGINEER UNDER THE LAWS OF THE STATE OF MINNESOTA.

Adam R. Jaden
 ADAM R. JADEN
 DATE: 02/29/2024 LIC. NO. 59337

CITY OF CHANHASSEN
 2024 CITY PAVEMENT
 REHABILITATION PROJECT

DRAINAGE PLAN & PROFILE
 76TH STREET
 STA. 26+50 TO STA. 33+00

CITY PROJECT	24-01	SHEET NO.
		96
		188

k:\TOW_Civil\City\CHANHASSEN\2024 CITY STREET REHAB-RECON\CAD\Plan Sheets\2024_PaveRehab_PSTRM.dwg March 01, 2024 - 10:20am

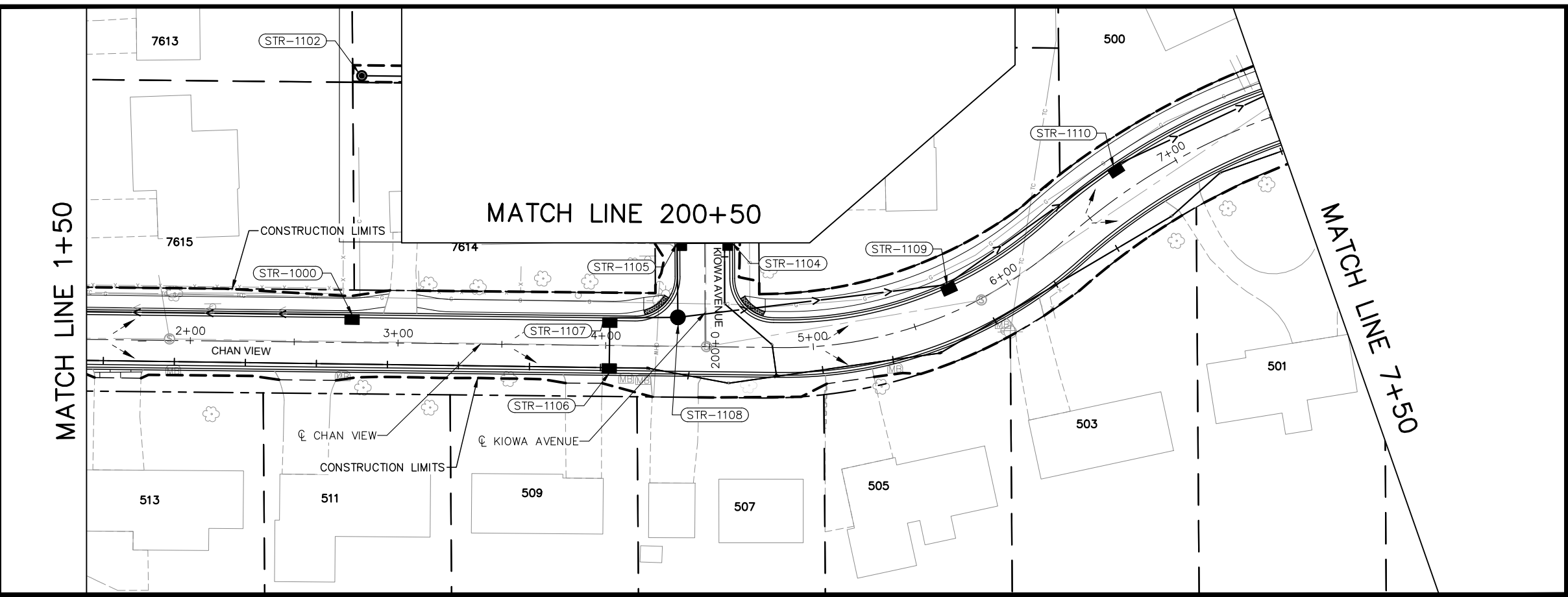

LEGEND:

- (STR-XXX) STRUCTURE NUMBER
- >— PROPOSED STORM SEWER
- - - - - PROPOSED DRAIN TILE
- ● ○ ▶ PROPOSED DRAINAGE STRUCTURE
- >— EXISTING STORM SEWER
- - - - - SURFACE FLOW DIRECTION

- GENERAL NOTES:**
1. SEE SHEETS 108 - 110 FOR STORM SEWER LATERAL PROFILES
- SPECIFIC NOTES:**
- ① GROUT DRAINAGE STRUCTURE
 - ② REPLACE CASTING AND ADJUST TO GRADE
 - ③ SUMP PUMP DISCHARGE CONNECTION PER CITY PLATE 5236
 - ④ CONNECT TO EXISTING STORM SEWER
 - ⑤ CONNECT INTO EXISTING DRAINAGE STRUCTURE
 - ⑥ INSTALL RIP RAP PER CITY PLATE 3107

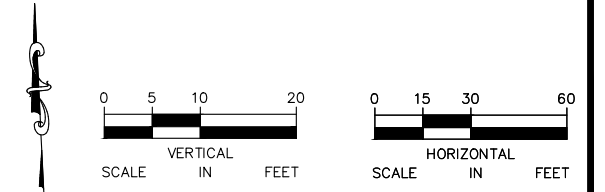
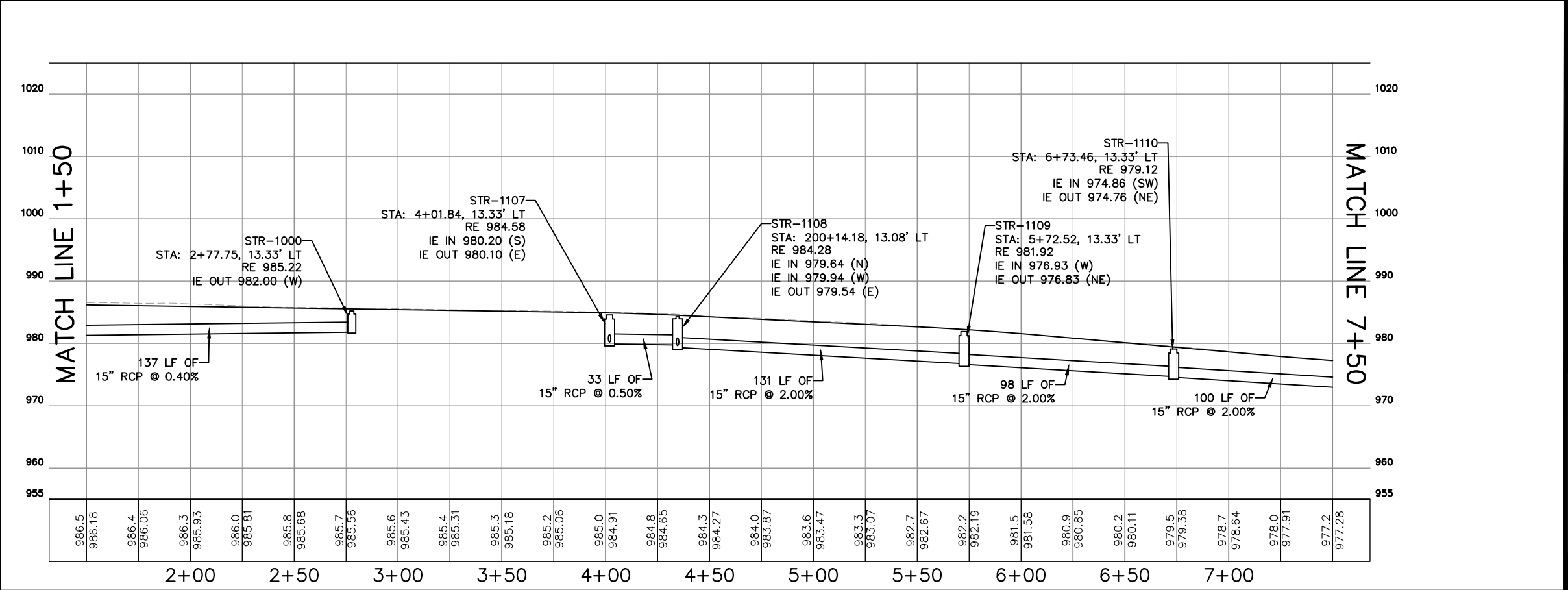

No.	Date	Revisions	App.

DRAWING NAME	2024_PaveRehab_PSTRM.dwg
DESIGNED BY:	WAS
DRAWN BY:	WAS
CHECKED BY:	ART
DATE:	02/29/2024
PROJECT NO.	24-01

Kimley»Horn

11995 SINGLETREE LANE, SUITE 225, EDEN PRAIRIE, MN 55344
 PHONE: 612-315-1272
 WWW.KIMLEY-HORN.COM

I HEREBY CERTIFY THAT THIS PLAN, SPECIFICATION OR REPORT WAS PREPARED BY ME OR UNDER MY DIRECT SUPERVISION AND THAT I AM A DULY LICENSED PROFESSIONAL ENGINEER UNDER THE LAWS OF THE STATE OF MINNESOTA.

Adam R. Loaden
 ADAM R. LOADEN
 DATE: 02/29/2024 LIC. NO. 59337



CITY OF CHANHASSEN
 2024 CITY PAVEMENT REHABILITATION PROJECT

DRAINAGE PLAN & PROFILE
 CHAN VIEW
 STA. 1+50 TO STA. 7+50

CITY PROJECT 24-01 SHEET NO. 97

188

k:\TOW_Civil\CITY\CHANHASSEN\2024 CITY STREET REHAB-RECON\CAD\Plan Sheets\2024_PaveRehab_PSTRM.dwg March 01, 2024 - 2:28pm

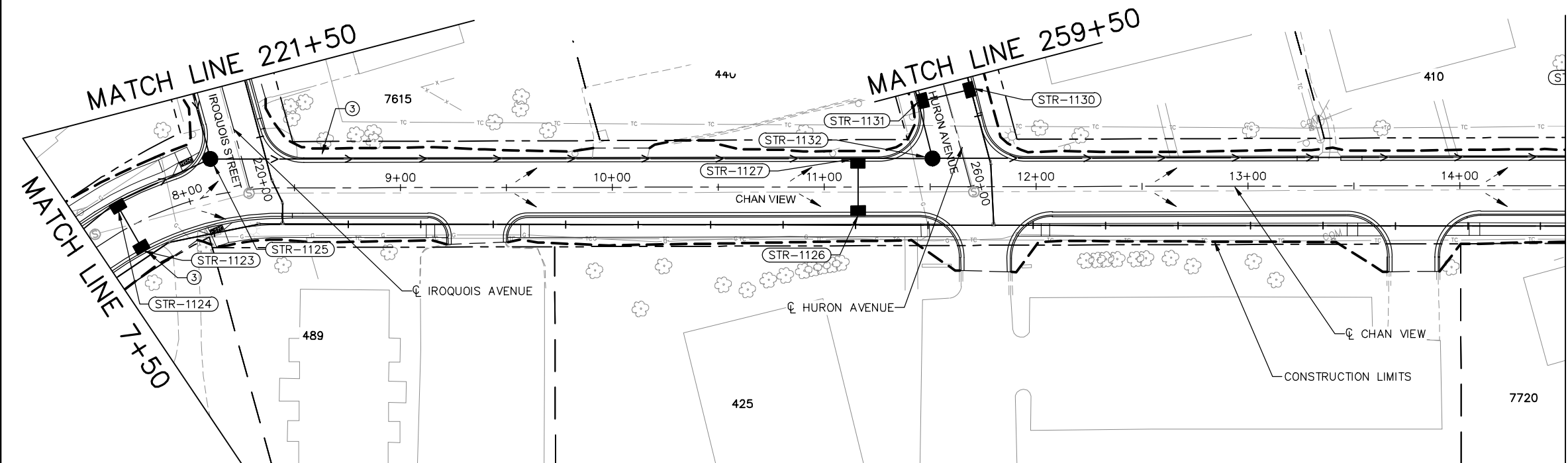

- LEGEND:**
- (STR-XXX) STRUCTURE NUMBER
 - PROPOSED STORM SEWER
 - - - - - PROPOSED DRAIN TILE
 - ● ○ ▶ PROPOSED DRAINAGE STRUCTURE
 - EXISTING STORM SEWER
 - - - - - SURFACE FLOW DIRECTION

- GENERAL NOTES:**
1. SEE SHEETS 108 - 110 FOR STORM SEWER LATERAL PROFILES
- SPECIFIC NOTES:**
- ① GROUT DRAINAGE STRUCTURE
 - ② REPLACE CASTING AND ADJUST TO GRADE
 - ③ SUMP PUMP DISCHARGE CONNECTION PER CITY PLATE 5236
 - ④ CONNECT TO EXISTING STORM SEWER
 - ⑤ CONNECT INTO EXISTING DRAINAGE STRUCTURE
 - ⑥ INSTALL RIP RAP PER CITY PLATE 3107

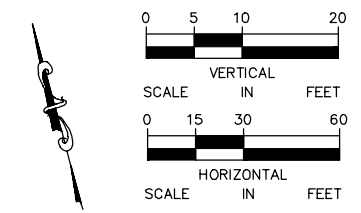
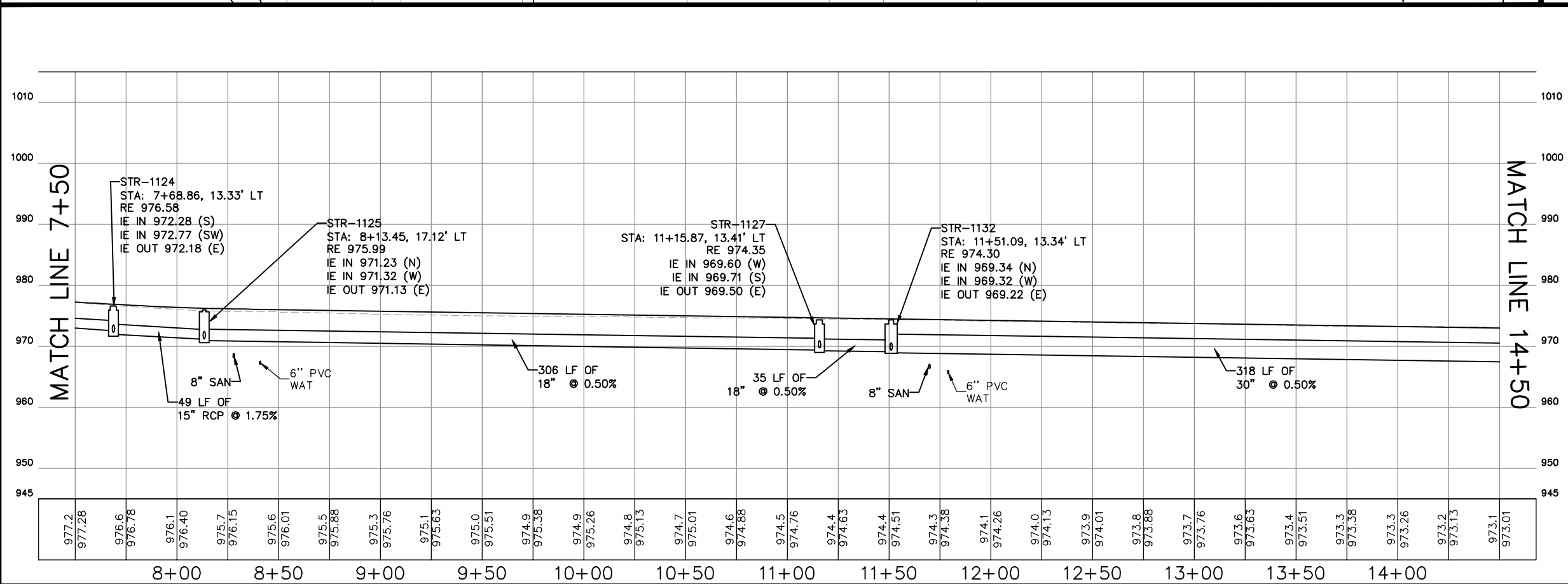

No.	Date	Revisions	App.

DRAWING NAME	
2024_PaveRehab_PSTRM.dwg	
DESIGNED BY:	WAS
DRAWN BY:	WAS
CHECKED BY:	ART
DATE:	02/29/2024
PROJECT NO.	24-01

Kimley»Horn

11995 SINGLETREE LANE, SUITE 225, EDEN PRAIRIE, MN 55344
 PHONE: 612-315-1272
 WWW.KIMLEY-HORN.COM

I HEREBY CERTIFY THAT THIS PLAN, SPECIFICATION OR REPORT WAS PREPARED BY ME OR UNDER MY DIRECT SUPERVISION AND THAT I AM A DULY LICENSED PROFESSIONAL ENGINEER UNDER THE LAWS OF THE STATE OF MINNESOTA.

Adam R. Joaden
 ADAM R. JOADEN
 DATE: 02/29/2024 MN LIC. NO. 59337



CITY OF CHANHASSEN
 2024 CITY PAVEMENT
 REHABILITATION PROJECT

DRAINAGE PLAN & PROFILE
 CHAN VIEW
 STA. 7+50 TO STA. 14+50

CITY PROJECT 24-01

SHEET NO. 98

188

k:\TOW_Civil\City\CHANHASSEN\2024 CITY STREET REHAB-RECON\ST\CAD\Plan Sheets\2024_PaveRehab_PSTRM.dwg March 01, 2024 - 10:20am

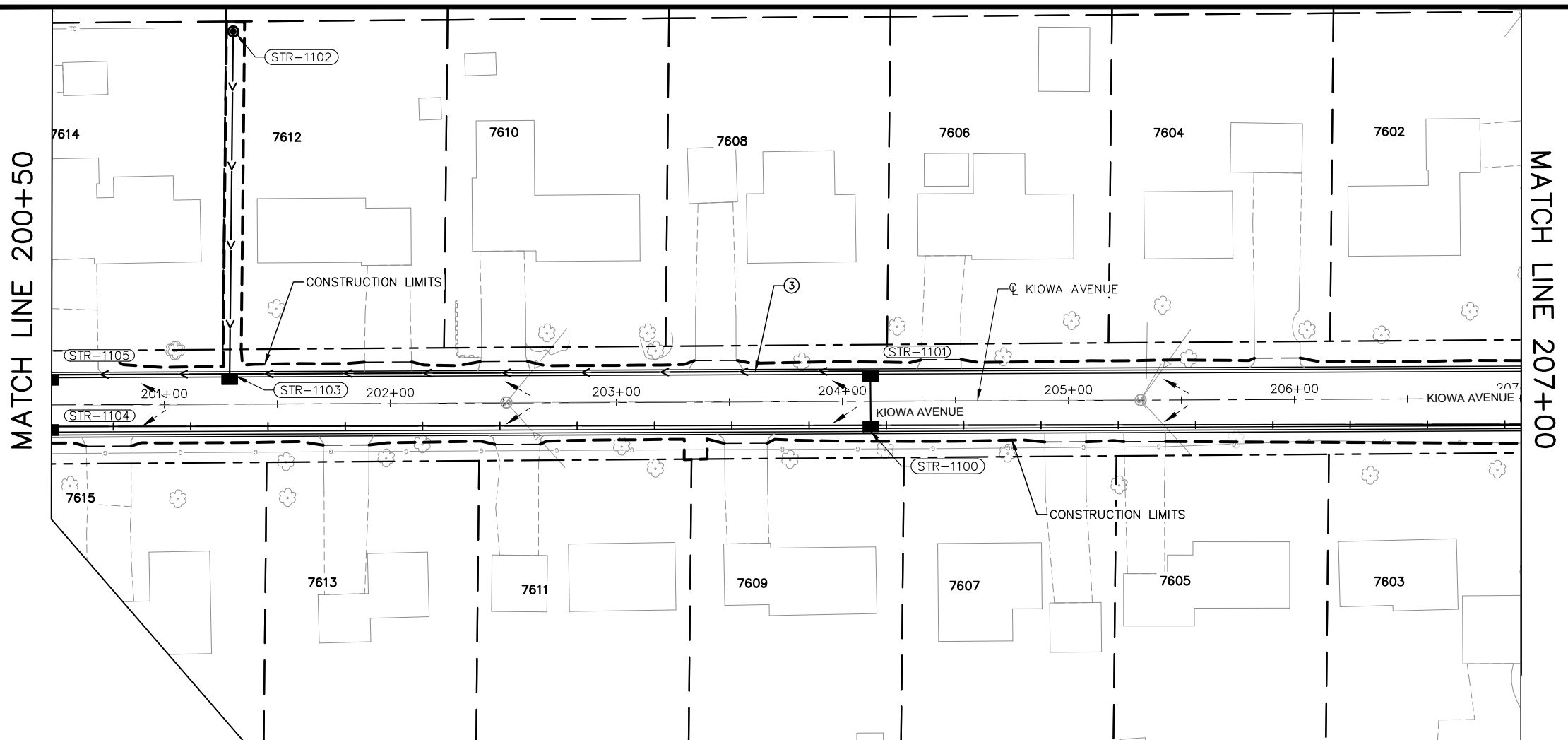

- LEGEND:**
- (STR-XXX) STRUCTURE NUMBER
 - >— PROPOSED STORM SEWER
 - - ->- - - PROPOSED DRAIN TILE
 - ● ○ ▶ PROPOSED DRAINAGE STRUCTURE
 - >— EXISTING STORM SEWER
 - - ->- - - SURFACE FLOW DIRECTION

- GENERAL NOTES:**
1. SEE SHEETS 108 - 110 FOR STORM SEWER LATERAL PROFILES

- SPECIFIC NOTES:**
- ① GROUT DRAINAGE STRUCTURE
 - ② REPLACE CASTING AND ADJUST TO GRADE
 - ③ SUMP PUMP DISCHARGE CONNECTION PER CITY PLATE 5236
 - ④ CONNECT TO EXISTING STORM SEWER
 - ⑤ CONNECT INTO EXISTING DRAINAGE STRUCTURE
 - ⑥ INSTALL RIP RAP PER CITY PLATE 3107

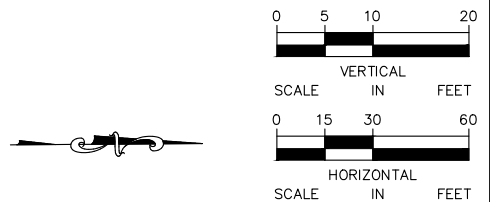
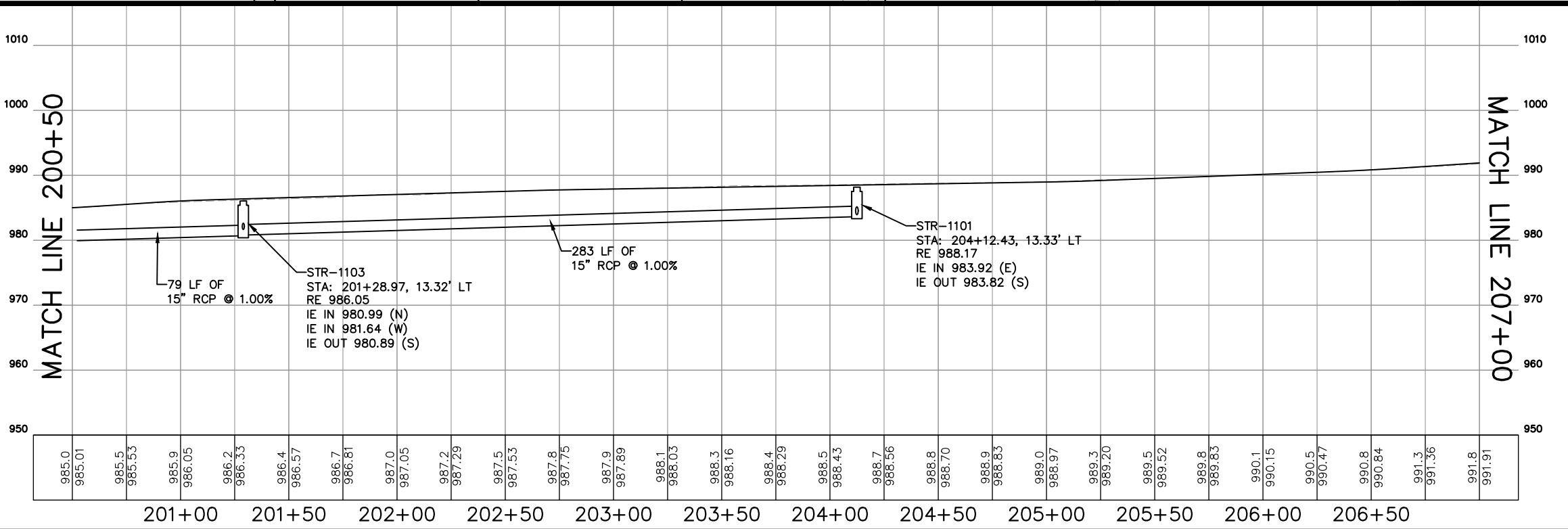

No.	Date	Revisions	App.

Kimley»Horn

11995 SINGLETREE LANE, SUITE 225, EDEN PRAIRIE, MN 55344
PHONE: 612-315-1272
WWW.KIMLEY-HORN.COM

I HEREBY CERTIFY THAT THIS PLAN, SPECIFICATION OR REPORT WAS PREPARED BY ME OR UNDER MY DIRECT SUPERVISION AND THAT I AM A DULY LICENSED PROFESSIONAL ENGINEER UNDER THE LAWS OF THE STATE OF MINNESOTA.

Adam R. Loaden
ADAM R. LOADEN
DATE: 02/29/2024 M.N. LIC. NO. 59337

CITY OF CHANHASSEN
2024 CITY PAVEMENT REHABILITATION PROJECT

DRAINAGE PLAN & PROFILE
KIOWA AVENUE
STA. 200+50 TO STA. 207+00

CITY PROJECT	24-01	SHEET NO.
		99
		188

k:\TOW\Civil\CHANHASSEN\2024 CITY STREET REHAB-RECON\ST\CAD\Plan Sheets\2024_PaveRehab_PSTRM.dwg March 01, 2024 - 10:20am

MATCH LINE 260+50

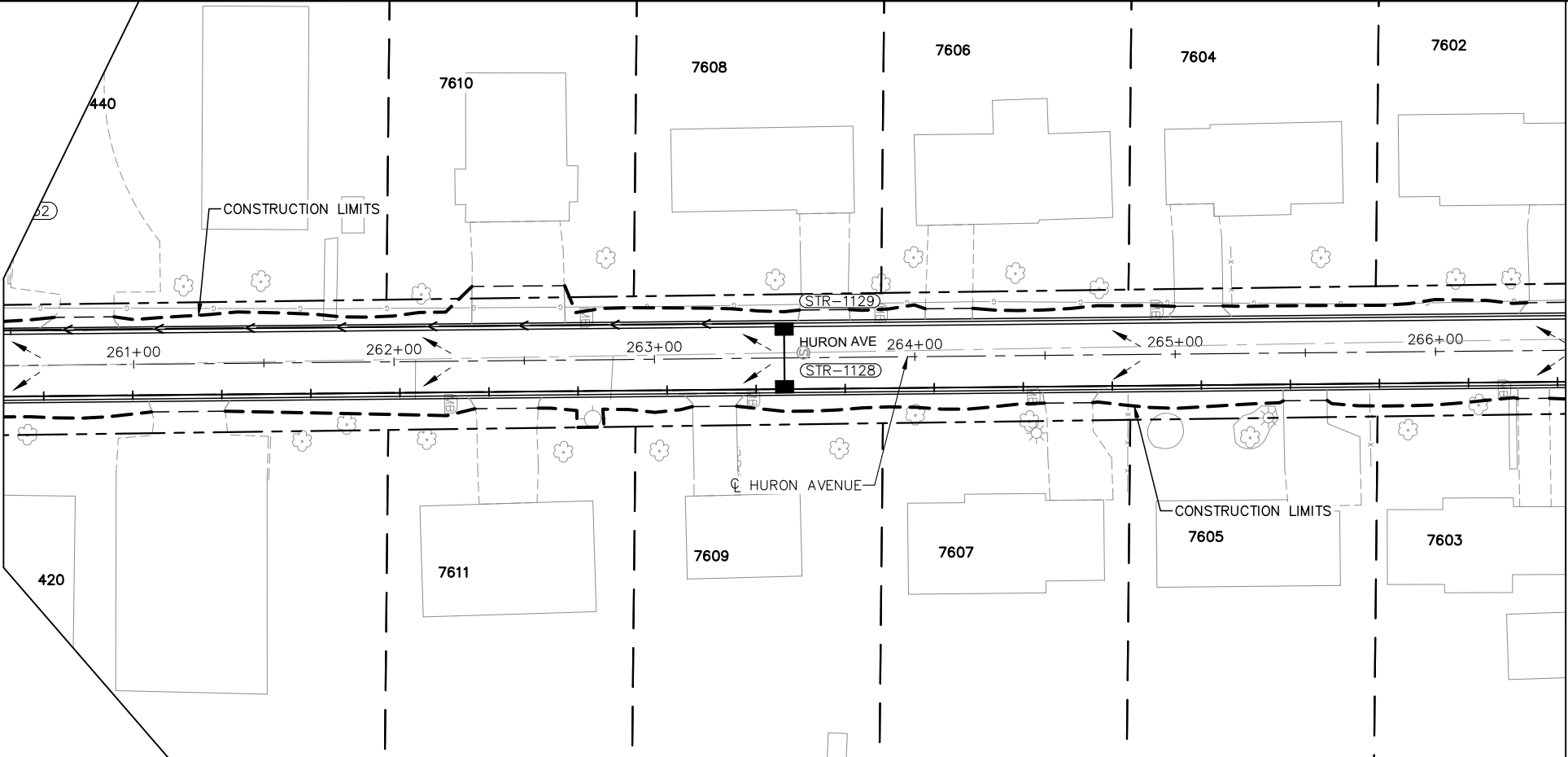

MATCH LINE 266+50

LEGEND:

- (STR-XXX) STRUCTURE NUMBER
- >— PROPOSED STORM SEWER
- - ->- - - PROPOSED DRAIN TILE
- ● ○ ▶ PROPOSED DRAINAGE STRUCTURE
- >— EXISTING STORM SEWER
- - ->- - - SURFACE FLOW DIRECTION

1. SEE SHEETS 108 - 110 FOR STORM SEWER LATERAL PROFILES

SPECIFIC NOTES:

- ① GROUT DRAINAGE STRUCTURE
- ② REPLACE CASTING AND ADJUST TO GRADE
- ③ SUMP PUMP DISCHARGE CONNECTION PER CITY PLATE 5236
- ④ CONNECT TO EXISTING STORM SEWER
- ⑤ CONNECT INTO EXISTING DRAINAGE STRUCTURE
- ⑥ INSTALL RIP RAP PER CITY PLATE 3107

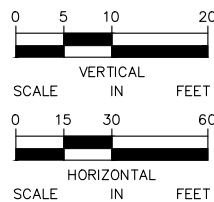
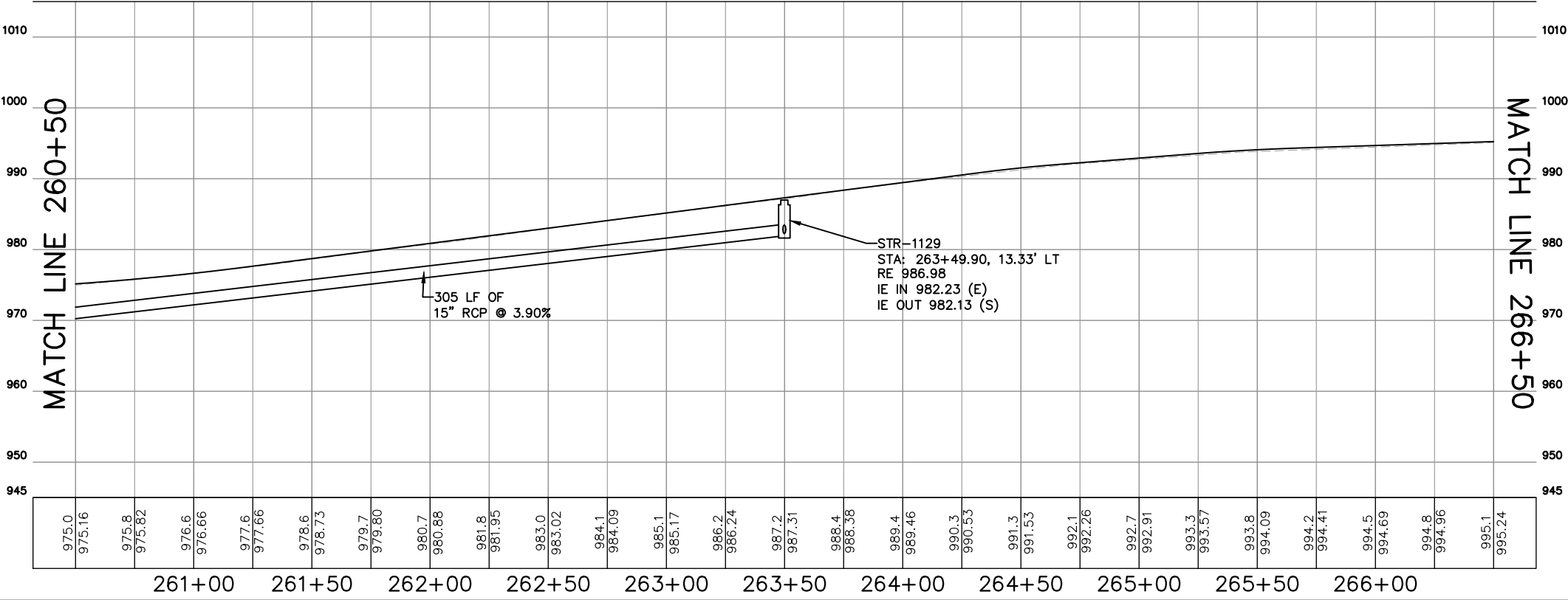

No.	Date	Revisions

App.	DRAWING NAME
	2024_PaveRehab_PSTRM.dwg
	DESIGNED BY: WAS
	DRAWN BY: WAS
	CHECKED BY: ART
	DATE: 02/29/2024
	PROJECT NO. 24-01

Kimley»Horn

11995 SINGLETREE LANE, SUITE 225, EDEN PRAIRIE, MN 55344
 PHONE: 612-315-1272
 WWW.KIMLEY-HORN.COM

I HEREBY CERTIFY THAT THIS PLAN, SPECIFICATION OR REPORT WAS PREPARED BY ME OR UNDER MY DIRECT SUPERVISION AND THAT I AM A DULY LICENSED PROFESSIONAL ENGINEER UNDER THE LAWS OF THE STATE OF MINNESOTA.

Adam R. Loaden
 ADAM R. LOADEN
 DATE: 02/29/2024 LIC. NO. 59337



CITY OF CHANHASSEN
 2024 CITY PAVEMENT REHABILITATION PROJECT

DRAINAGE PLAN & PROFILE
 HURON AVENUE
 STA. 260+50 TO STA. 266+50

CITY PROJECT 24-01

SHEET NO. 101

188

k:\TOW_Civil\CITY\CHANHASSEN\2024 CITY STREET REHAB-RECON\ST\CAD\Plan Sheets\2024_PaveRehab_PSTRM.dwg March 01, 2024 - 10:21am

MATCH LINE 280+50

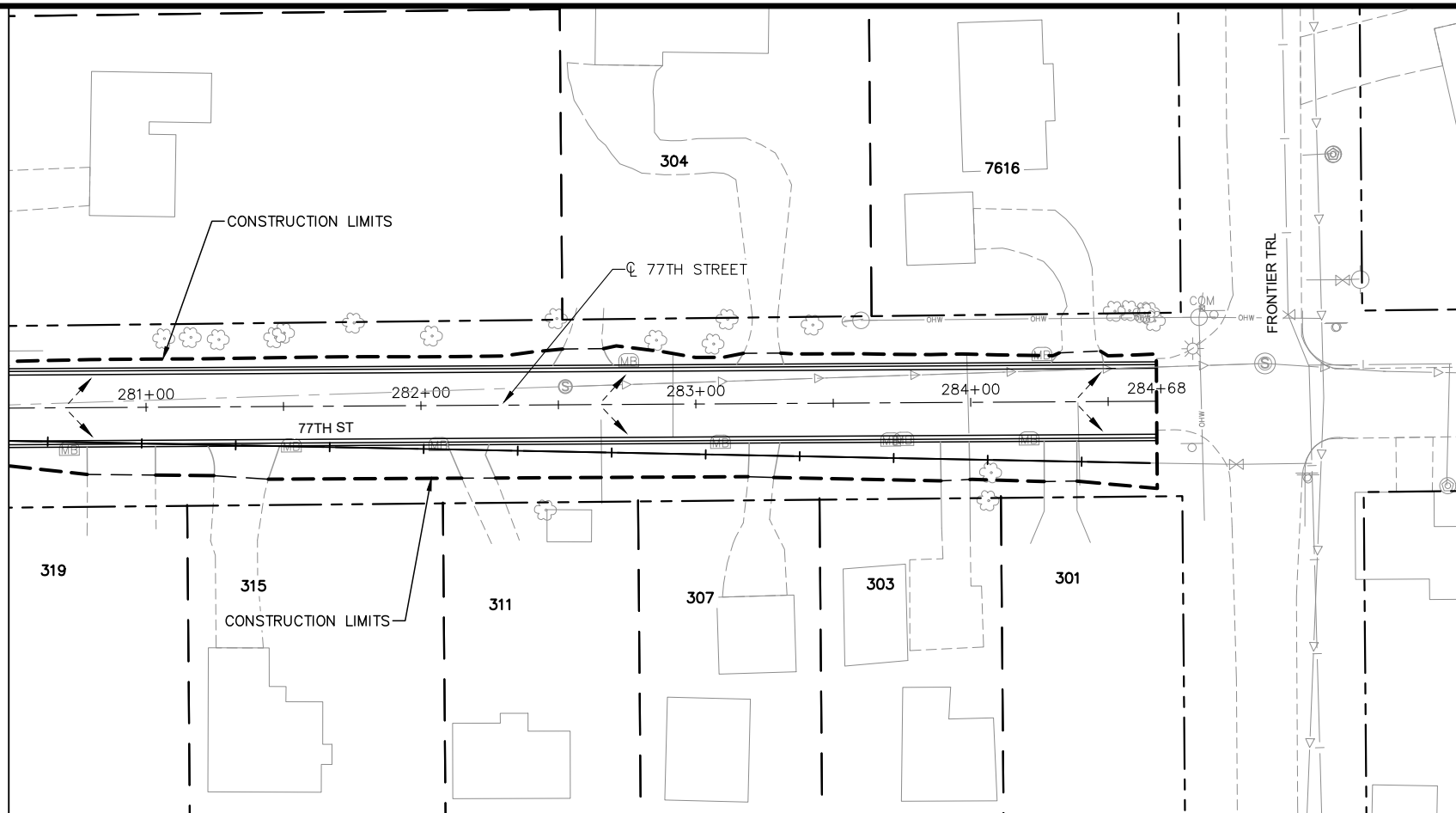

LEGEND:

- (STR-XXX) STRUCTURE NUMBER
- >— PROPOSED STORM SEWER
- - ->- - - PROPOSED DRAIN TILE
- ○ ● PROPOSED DRAINAGE STRUCTURE
- >— EXISTING STORM SEWER
- ->- - SURFACE FLOW DIRECTION

GENERAL NOTES:

1. SEE SHEETS 108 - 110 FOR STORM SEWER LATERAL PROFILES

SPECIFIC NOTES:

- ① GROUT DRAINAGE STRUCTURE
- ② REPLACE CASTING AND ADJUST TO GRADE
- ③ SUMP PUMP DISCHARGE CONNECTION PER CITY PLATE 5236
- ④ CONNECT TO EXISTING STORM SEWER
- ⑤ CONNECT INTO EXISTING DRAINAGE STRUCTURE
- ⑥ INSTALL RIP RAP PER CITY PLATE 3107

MATCH LINE 280+50

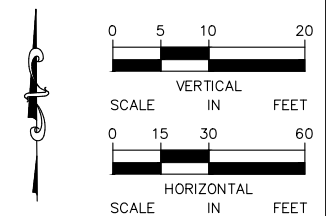
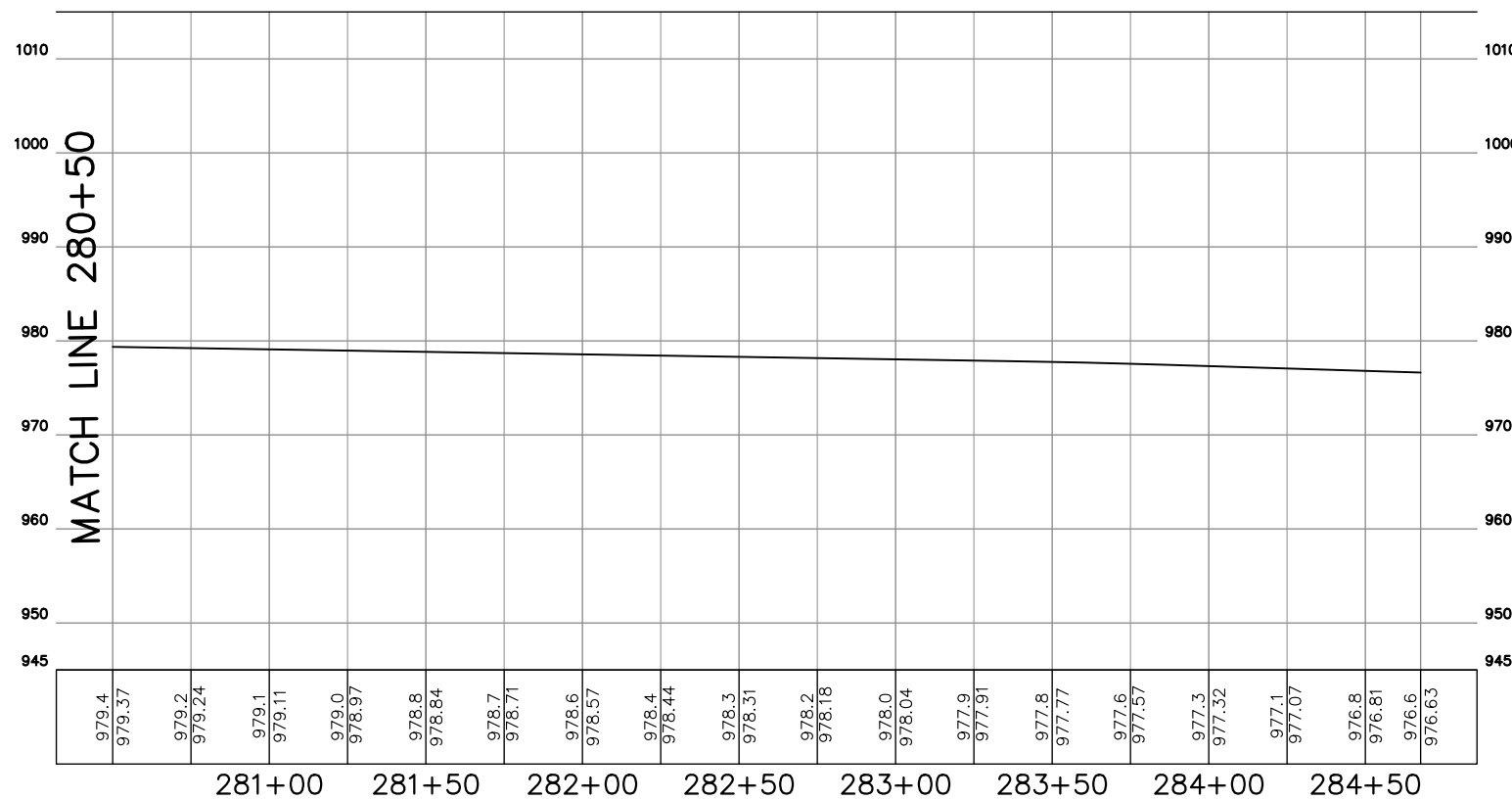

No.	Date	Revisions	App.

DRAWING NAME	2024_PaveRehab_PSTRM.dwg
DESIGNED BY:	WAS
DRAWN BY:	WAS
CHECKED BY:	ART
DATE:	02/29/2024
PROJECT NO.	24-01

Kimley»Horn

11995 SINGLETREE LANE, SUITE 225, EDEN PRAIRIE, MN 55344
 PHONE: 612-315-1272
 WWW.KIMLEY-HORN.COM

I HEREBY CERTIFY THAT THIS PLAN, SPECIFICATION OR REPORT WAS PREPARED BY ME OR UNDER MY DIRECT SUPERVISION AND THAT I AM A DULY LICENSED PROFESSIONAL ENGINEER UNDER THE LAWS OF THE STATE OF MINNESOTA.

Adam R. Jaden
 ADAM R. JADEN
 DATE: 02/29/2024 LIC. NO. 59337



CITY OF CHANHASSEN
 2024 CITY PAVEMENT
 REHABILITATION PROJECT

DRAINAGE PLAN & PROFILE
 77TH STREET
 STA. 280+50 TO STA. 284+68

CITY PROJECT 24-01

SHEET NO. 102

188

k:\TOW_Civil\City\CHANHASSEN\2024 CITY STREET REHAB-RECON\2024_PaveRehab_PSTRM.dwg March 01, 2024 - 2:43pm

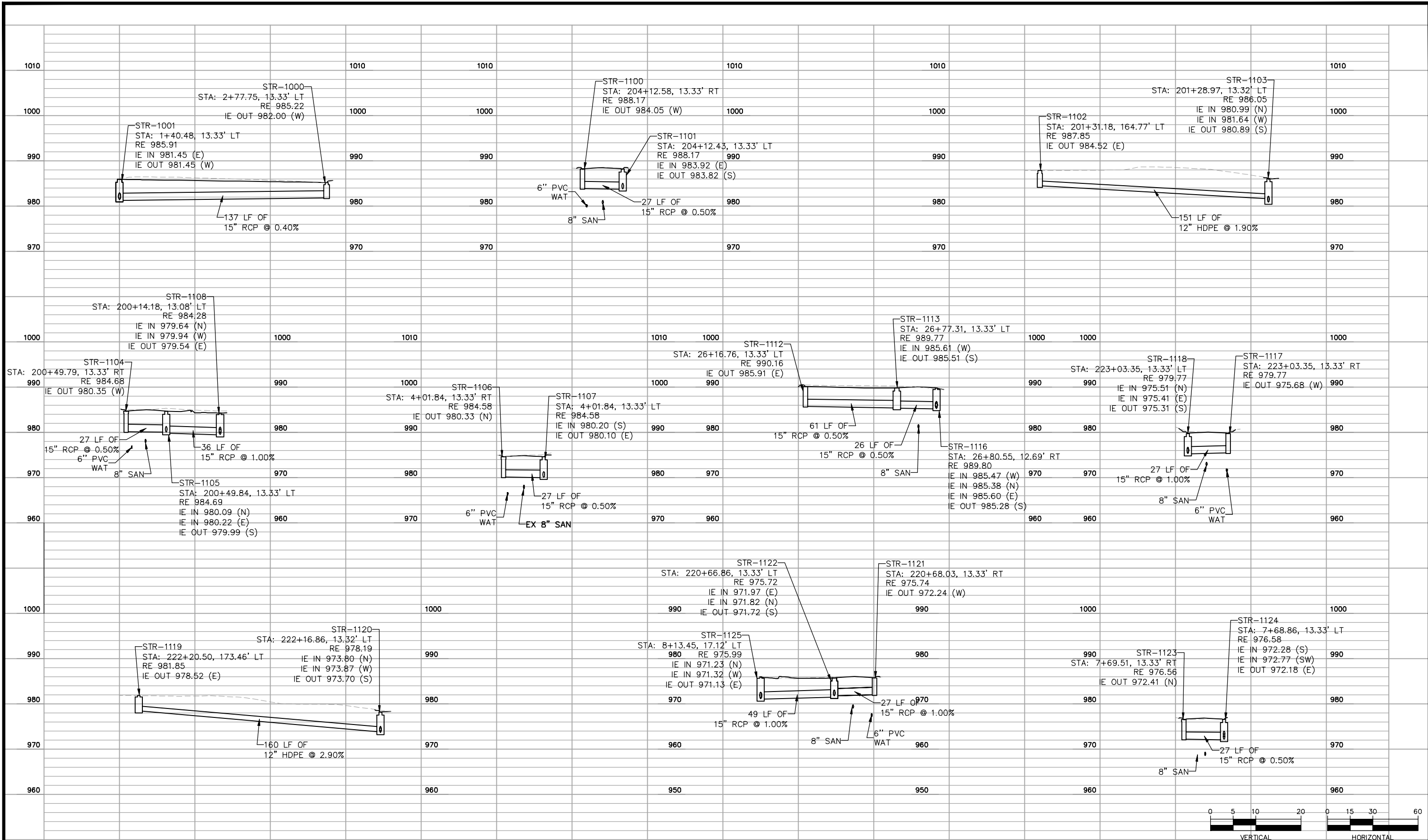

No.	Date	Revisions	App.

DRAWING NAME	
DESIGNED BY:	WAS
DRAWN BY:	WAS
CHECKED BY:	ART
DATE:	02/29/2024
PROJECT NO.	24-01

Kimley»Horn

11995 SINGLETREE LANE, SUITE 225, EDEN PRAIRIE, MN 55344
 PHONE: 612-315-1272
 WWW.KIMLEY-HORN.COM

I HEREBY CERTIFY THAT THIS PLAN, SPECIFICATION OR REPORT WAS PREPARED BY ME OR UNDER MY DIRECT SUPERVISION AND THAT I AM A DULY LICENSED PROFESSIONAL ENGINEER UNDER THE LAWS OF THE STATE OF MINNESOTA.

Adam R. Joaden
 ADAM R. JOADEN
 DATE: 02/29/2024 LIC. NO. 59337



CITY OF CHANHASSEN
 2024 CITY PAVEMENT REHABILITATION PROJECT

CITY PROJECT 24-01 SHEET NO. 108

DRAINAGE LATERAL PROFILES

188

k:\TOW_Civil\City\CHANHASSEN\2024 CITY STREET REHAB-RECON\CAD\Plan Sheets\2024_PaveRehab_PSTRM.dwg March 01, 2024 - 2:43pm

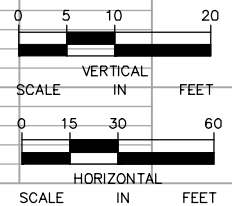
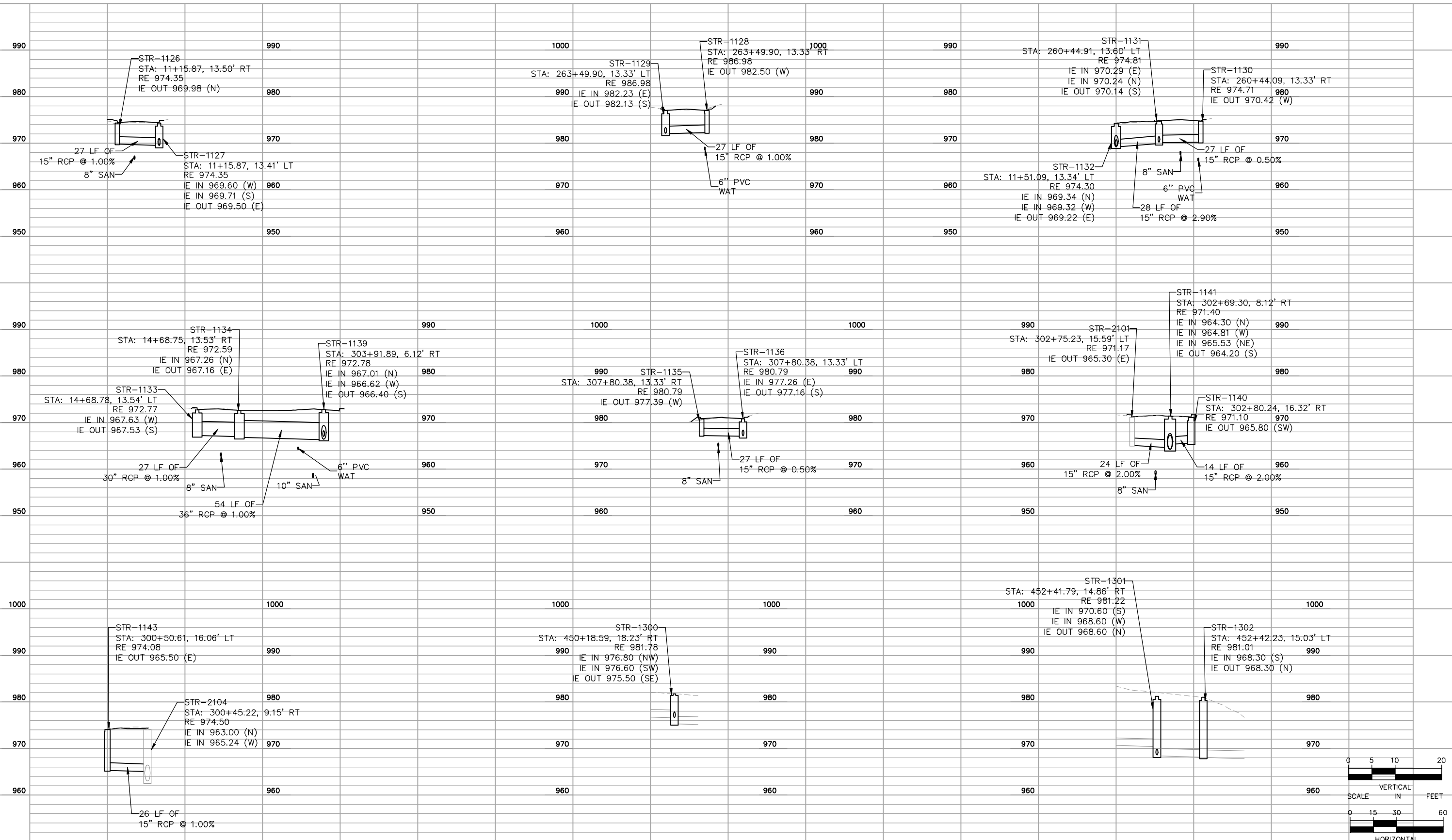

No.	Date	Revisions

App.	DRAWING NAME
	2024_PaveRehab_PSTRM.dwg
	DESIGNED BY: WAS
	DRAWN BY: WAS
	CHECKED BY: ART
	DATE: 02/29/2024
	PROJECT NO. 24-01

Kimley»Horn

11995 SINGLETREE LANE, SUITE 225, EDEN PRAIRIE, MN 55344
 PHONE: 612-315-1272
 WWW.KIMLEY-HORN.COM

I HEREBY CERTIFY THAT THIS PLAN, SPECIFICATION OR REPORT WAS PREPARED BY ME OR UNDER MY DIRECT SUPERVISION AND THAT I AM A DULY LICENSED PROFESSIONAL ENGINEER UNDER THE LAWS OF THE STATE OF MINNESOTA.

Adam R. Joaden
 ADAM R. JOADEN
 DATE: 02/29/2024 LIC. NO. 59337



CITY OF CHANHASSEN
 2024 CITY PAVEMENT
 REHABILITATION PROJECT

DRAINAGE LATERAL PROFILES

CITY PROJECT 24-01

SHEET NO. 109

188

k:\TOW_Civil\City\CHANHASSEN\2024 CITY STREET REHAB-RECON\2024_PaveRehab_PSTRM.dwg March 01, 2024 - 2:43pm

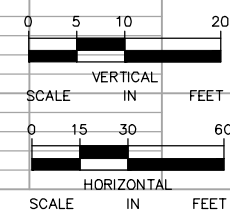
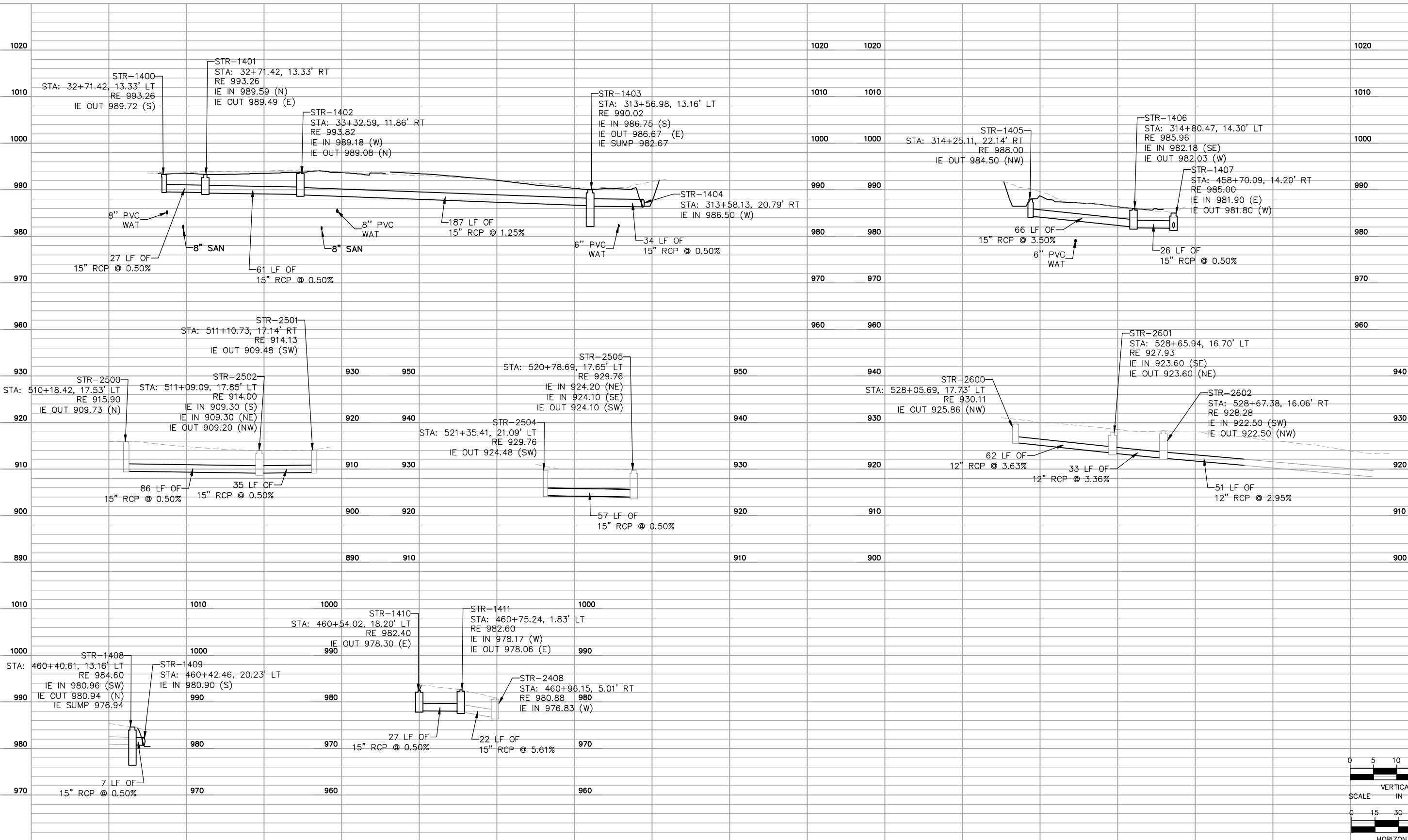

No.	Date	Revisions	App.

DRAWING NAME	2024_PaveRehab_PSTRM.dwg
DESIGNED BY:	WAS
DRAWN BY:	WAS
CHECKED BY:	ART
DATE:	02/29/2024
PROJECT NO.	24-01

Kimley»Horn

11995 SINGLETREE LANE, SUITE 225, EDEN PRAIRIE, MN 55344
 PHONE: 612-315-1272
 WWW.KIMLEY-HORN.COM

I HEREBY CERTIFY THAT THIS PLAN, SPECIFICATION OR REPORT WAS PREPARED BY ME OR UNDER MY DIRECT SUPERVISION AND THAT I AM A DULY LICENSED PROFESSIONAL ENGINEER UNDER THE LAWS OF THE STATE OF MINNESOTA.

Adam R. Joaden
 ADAM R. JOADEN
 DATE: 02/29/2024 LIC. NO. 59337



CITY OF CHANHASSEN
 2024 CITY PAVEMENT
 REHABILITATION PROJECT

DRAINAGE LATERAL PROFILES

CITY PROJECT 24-01

SHEET NO.
110
188

RAINGARDEN SAMPLE PLANTING PLANS

RAINGARDEN PREPERATION NOTES

RAINGARDEN SAMPLE PLANTING PLAN - SHRUB (~200 SF)			
COMMON NAME	SCIENTIFIC NAME	SIZE	QTY
BOTTOM AND EDGE OF GARDEN			
BLACK CHOKEBERRY	ARONIA MELANOCARPA FLATA	#5 CONT.	1
DWARF BUSH HONEYSUCKLE	DIERVILLA LONICERA	#5 CONT.	1
GOLDFLAME SPIREA	SPIRAEA X RUMALIDA 'GOLDFLAME'	#5 CONT.	1
NANTY REDOXIFR DOGWOOD	CORNUS SERICEA 'NANTY'	#5 CONT.	1
TOTAL			10

RAINGARDEN SAMPLE PLANTING PLAN - SUNNY (~200 SF)			
COMMON NAME	SCIENTIFIC NAME	SIZE	QTY
BOTTOM OF GARDEN			
BLACK-EYED SUSAN	RUDBECKIA HERTA	#1 CONT.	4
ROUGH BLAZING STAR	LIATRIS ASPERA	#1 CONT.	6
LITTLE BLUESTEM	SCHIZACHYRIUM SCOPARIUM	#1 CONT.	6
NEW ZEALAND FLAX	CYANTHUS AMERICANUS	#1 CONT.	2
SHOWY GOLDENROD	SOLIDAGO SPECIOSA	#1 CONT.	2
SWIFT ICE PINE WIND	FILIPENDULA PURPUREA	#1 CONT.	3
EDGE OF GARDEN			
PURPLE PRAIRIE CLOVER	DAI FA PURPUREA	#1 CONT.	7
CREAM FALSE INDIGO	BAPTISIA BRACTEATE	#1 CONT.	3
BUTTERFLY WEED	ASCLEPIAS TUBEROSA	#1 CONT.	6
WILD LUPINE	LUPINUS PERENNIS	#1 CONT.	9
PRAIRIE SMOKF	GEUM TRIFLOLUM	#1 CONT.	8
PINK PUSSYTOES	ANTENNARIA DIODICA RUBRA	#1 CONT.	4
TOTAL			60

RAINGARDEN SAMPLE PLANTING PLAN - SHADY (~200 SF)			
COMMON NAME	SCIENTIFIC NAME	SIZE	QTY
BOTTOM OF GARDEN			
MAIDENHAIR FERN	ADIANTUM PEDATUM	#1 CONT.	5
SOLOMON'S SEAL	POLYGONATUM BIFLORUM	#1 CONT.	5
COLUMBINE	ACURLEGIA CANADENSIS	#1 CONT.	6
PALM SEDGE	CAREX MUSKINGUMENSIS	#1 CONT.	5
WHITE TURFTILED	CHLOROCYBIS	#1 CONT.	5
GRASSY WOODRIDGE	DIELIS SIBIRICA	#1 CONT.	4
CULVER'S ROOT	VERONICASTRUM VIRGINICUM	#1 CONT.	3
EDGE OF GARDEN			
WILD GINGER	ASARUM CANADENSE	#1 CONT.	6
WILD GERANIUM	GERANIUM MACULATUM	#1 CONT.	6
BIG-LEAVED ASTER	ASTER MACROPHYLLUS	#1 CONT.	5
BRADBURY'S MONARDA	MONARDA BRADBURIANA	#1 CONT.	3
TRICOLOR DOGWOOD	SOLIDAGO FLEXIBILIS	#1 CONT.	5
TOTAL			60

- DURING THE GRADING PROCESS, THE EXISTING IN SITU TOPSOIL SHALL BE SALVAGED TO BE USED TO CREATE THE BEDDING MATERIAL. SALVAGED TOP SOIL SHALL BE FREE AND CLEAN OF SEED BEARING VEGETATION.
- THE RAINWATER GARDENS SHALL BE EXCAVATED TO THE DEPTH AND SIZE REQUIRED.
- THE RAINWATER GARDEN AREA SHALL BE OVER-EXCAVATED AN ADDITIONAL 24" TO ALLOW FOR THE PLACEMENT OF 24" OF FILTER TOPSOIL BORROW. FILTER TOPSOIL BORROW MAY BE MIXED WITHIN THE GARDEN AREA OR OUTSIDE THE GARDEN AREA AND SHALL BE APPROXIMATELY 50% SALVAGED IN SITU TOP SOIL AND 50% CLEAN ORGANIC COMPOST, GRADE 2. NO IMPORTED TOPSOIL WILL BE PERMITTED IN THE GARDEN AREAS.
- THE SUBSOILS IN THE ENTIRE GARDEN AREA MUST BE THOROUGHLY AND DEEPLY SCARIFIED BEFORE THE CONTRACTOR PLACES THE BEDDING MATERIAL. SCARIFYING MUST BE DONE WITH A "TOOTHED" BACKHOE.
- ONCE THE RAIN GARDEN AREAS ARE PREPARED, COVER THE BEDDING MATERIAL WITH A MAXIMUM 2" OF TYPE 6 MULCH (INCIDENTAL) AND PROTECT THE GARDEN WITH SILT FENCE IF EROSION FROM THE SURROUNDING AREA IS A CONCERN PRIOR TO TURF BEING ESTABLISHED.

PLAN VIEW

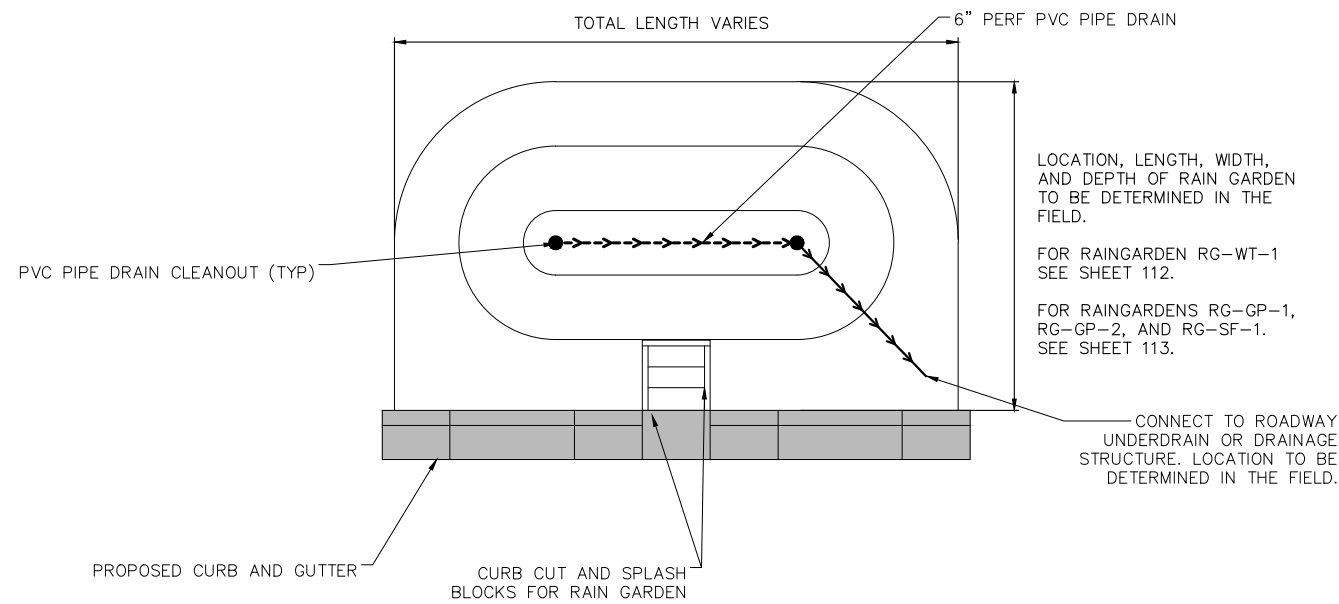

PROFILE VIEW

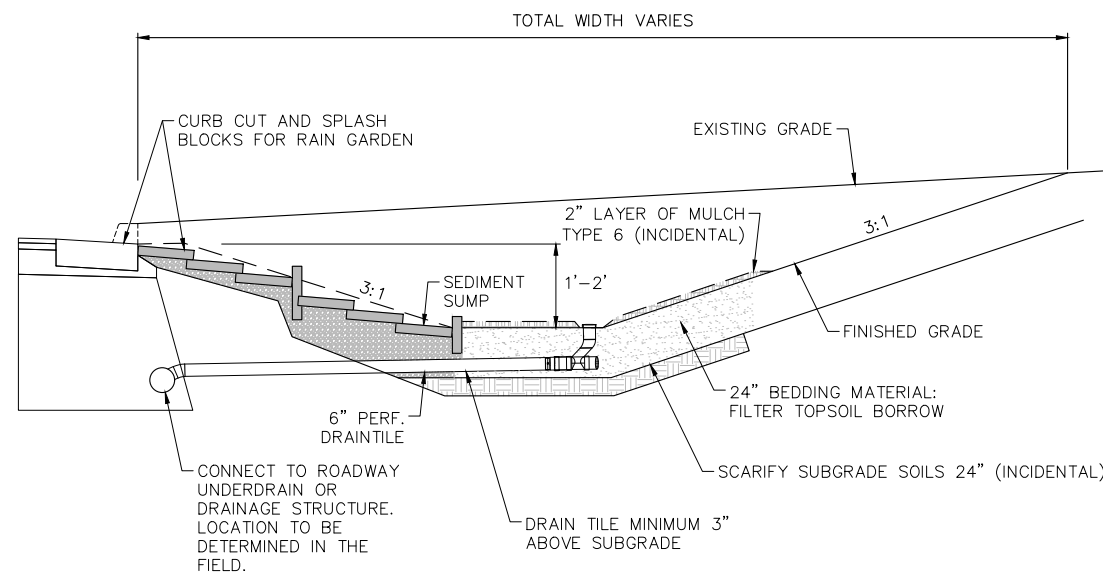

CONSTRUCT DRAINAGE STRUCTURE DESIGN SPECIAL 2 (SPLASH BLOCK ASSEMBLY)

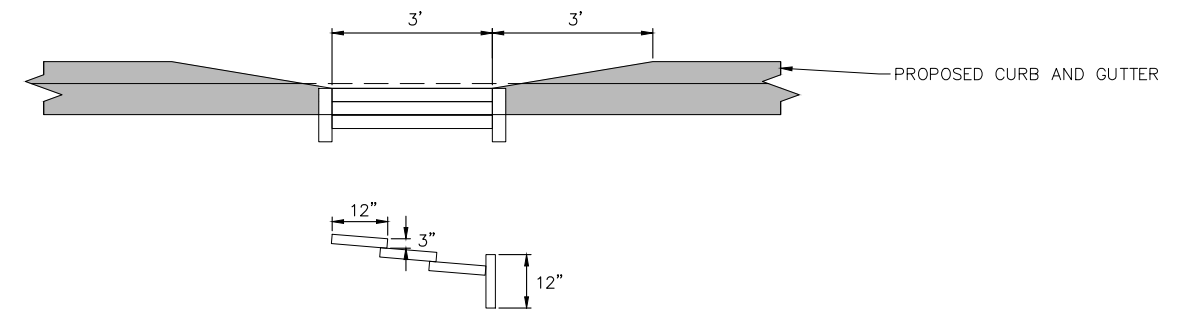

SPLASH BLOCK ASSEMBLY STONE UNIT DIMENSIONS SHALL BE 1' X 3' X 3".

CONSTRUCT 3' X 1' X 3' COMPLETE SPLASH BLOCK ASSEMBLY AS ENCLOSED BOX TYPE STRUCTURE. GLUE JOINTS AS DIRECTED.

PLACE IN STEPPED METHOD WITH 1" OVERLAP. EACH STEP SHALL HAVE 1" VERTICAL DROP.

PLACE 3" LAYER OF PEA GRAVEL UNDER SPLASH BLOCK ASSEMBLY

CONSTRUCT 3' WIDE DROP DOWN CURB CUT OPENING TO SLOPE TOWARDS RAIN GARDEN WIT 3' TRANSITION. CENTER SPLASH BLOCK ASSEMBLY AT CURB CUT.

*ALL ITEMS LISTED ABOVE TO BE PAID UNDER RAIN GARDEN

k:\TOW_Civil\City\CHANHASSEN\2024 CITY STREET REHAB-RECON\CAD\Plan Sheets\2024_PaveRehab_PSTRM-DET.dwg March 01, 2024 - 10:42am

No.	Date	Revisions	App.	DRAWING NAME
				2024_PaveRehab_PSTRM-DET.dwg
				DESIGNED BY: WAS
				DRAWN BY: WAS
				CHECKED BY: MAK
				DATE: 02/29/2024
				PROJECT NO. 24-01

Kimley»Horn

11995 SINGLETREE LANE, SUITE 225, EDEN PRAIRIE, MN 55344
PHONE: 612-315-1272
WWW.KIMLEY-HORN.COM

I HEREBY CERTIFY THAT THIS PLAN, SPECIFICATION OR REPORT WAS PREPARED BY ME OR UNDER MY DIRECT SUPERVISION AND THAT I AM A DULY LICENSED PROFESSIONAL ENGINEER UNDER THE LAWS OF THE STATE OF MINNESOTA.

Adam R. Loaden
ADAM R. LOADEN
DATE: 02/29/2024 MIN. LIC. NO. 59337



CITY OF CHANHASSEN
2024 CITY PAVEMENT
REHABILITATION PROJECT

RAIN GARDEN TYPICAL DETAIL

CITY PROJECT	24-01	SHEET NO.	111
		188	

k:\TOW_Civil\City\CHANHASSEN 2024 CITY STREET REHAB-RECONSTRUCT\CAD\Plan Sheets\2024_PaveRehab_PSTRM-GRAD-GP.dwg March 01, 2024 - 1:55pm

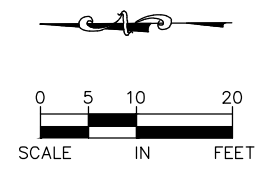
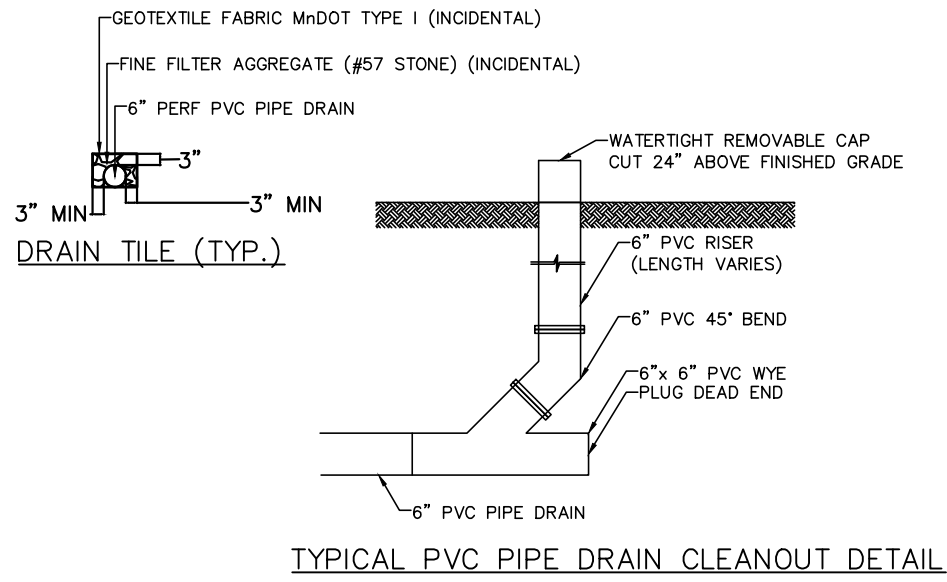
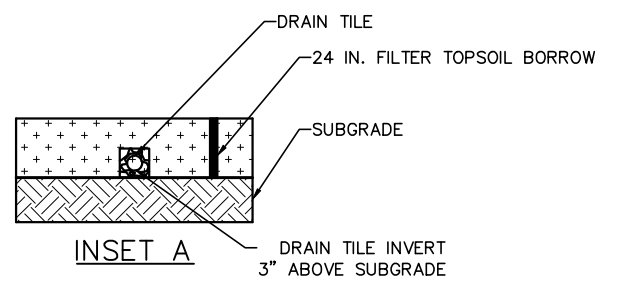
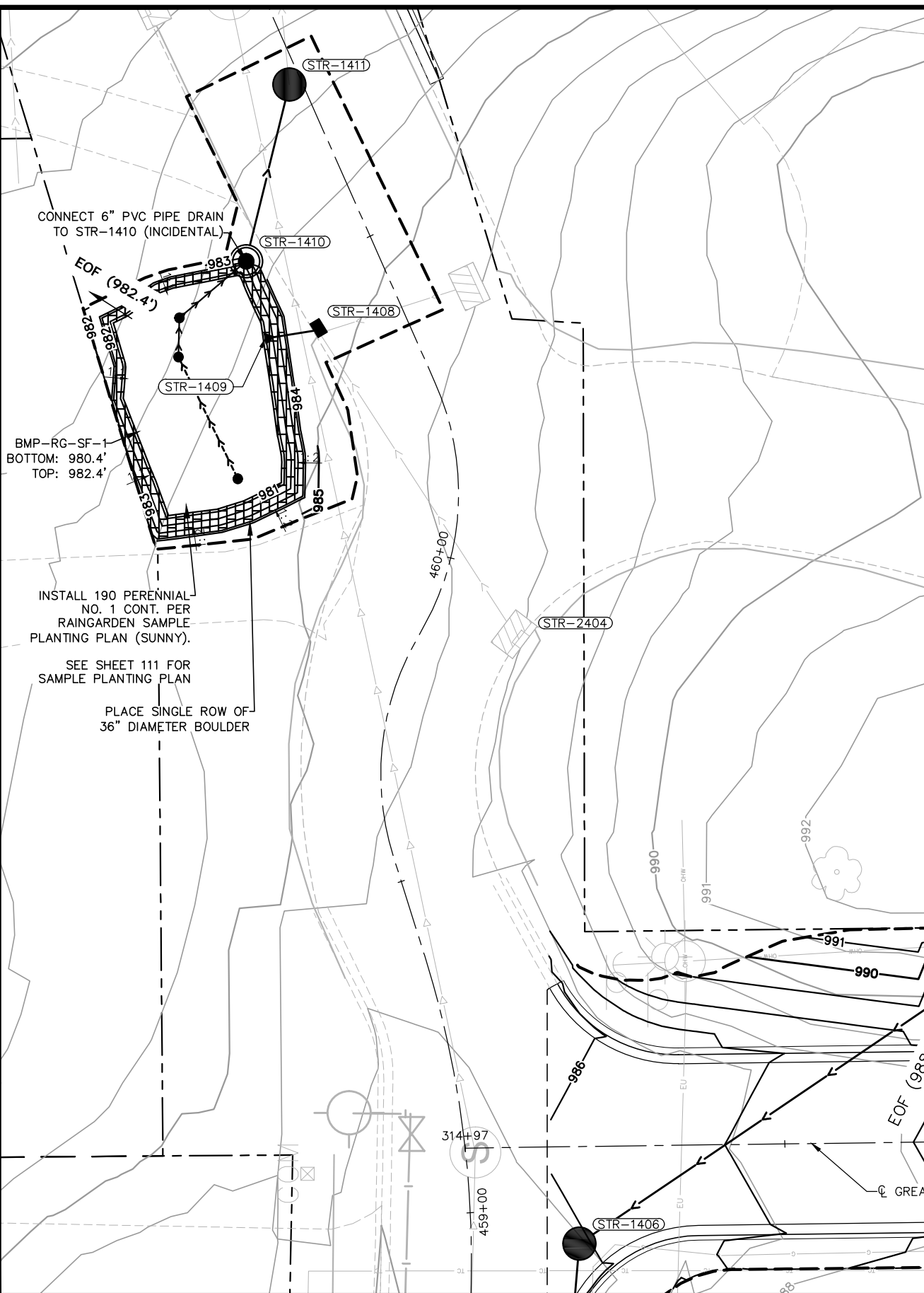

- LEGEND:**
- 900 — INPLACE CONTOURS
 - 901 — PROPOSED CONTOURS
 - → → → 6" PERF PVC PIPE DRAIN (@ 0.5%)
 - → → → 6" PVC PIPE DRAIN (@ 0.5%)
 - ▣▣▣▣▣▣ 36" DIAMETER BOULDERS
 - 6" PVC PIPE DRAIN CLEANOUT
 - ← EOF → EMERGENCY OVERFLOW DIRECTION
 - 1:3 SLOPE

- NOTES:**
1. STOCKPILING MATERIALS IS NOT ALLOWED IN PROPOSED BASIN AREAS.
 2. DISTURBED RAIN GARDEN AREAS SHALL BE SCARIFIED TO A MINIMUM DEPTH OF 24" INTO SUB-SOILS AT BOTTOM OF EXCAVATION OR OVEREXCAVATION, WITH A FROST-RIPPING TOOTH, AT A MAXIMUM SPACING OF 18" BETWEEN RIPPING PASSES (INCIDENTAL).
 3. SEE SHEET 108 - 110 FOR STORM SEWER LATERALS.
 4. UNDERDRAIN REQUIREMENTS
 - 4.1. 6" PVC SCH40 WITH 3/8 IN. PERFORATIONS, WITH TRACER WIRE.
 - 4.2. MINIMUM DRAINTILE GRADE SHALL BE 0.5%.
 - 4.3. CLEANOUTS AT PIPE ENDS CUT TWO FEET ABOVE FINISHED GRADE WITH WATERTIGHT REMOVABLE CAPS.
 - 4.4. MAXIMUM 45-DEGREE BENDS.
 - 4.5. CONNECTIONS SHALL BE WYE FITTINGS.
 5. RAIN GARDEN SHALL NOT BE EXCAVATED UNTIL CONSTRUCTION WITHIN THE CONTRIBUTING DRAINAGE AREA HAS BEEN COMPLETED AND FULLY STABILIZED.
 6. DISTURBED RAIN GARDEN AREA SHALL BE RIPPED TO A DEPTH OF 24 INCHES THEN TILLED TO A MINIMUM DEPTH OF 8 INCHES PRIOR TO SEEDING (INCIDENTAL). DO NOT PLACE TOPSOIL WITHIN RAIN GARDEN BOTTOM.
 7. CONTRACTOR SHALL REMOVE ANY ACCUMULATED SEDIMENTS WITHIN THE RAIN GARDEN AREA AS A RESULT OF CONSTRUCTION ACTIVITY.

No.	Date	Revisions	App.
			2024

DESIGNED BY:	ART
DRAWN BY:	ART
CHECKED BY:	MAK
DATE:	02/29/2024
PROJECT NO.	24-01

Kimley»Horn

11995 SINGLETREE LANE, SUITE 225, EDEN PRAIRIE, MN 55344
 PHONE: 612-315-1272
 WWW.KIMLEY-HORN.COM

I HEREBY CERTIFY THAT THIS PLAN, SPECIFICATION OR REPORT WAS PREPARED BY ME OR UNDER MY DIRECT SUPERVISION AND THAT I AM A DULY LICENSED PROFESSIONAL ENGINEER UNDER THE LAWS OF THE STATE OF MINNESOTA.

Adam R. Jaden
 ADAM R. JADEN
 DATE: 02/29/2024 LIC. NO. 59337

CITY OF CHANHASSEN
 2024 CITY PAVEMENT
 REHABILITATION PROJECT

RAIN GARDEN PLAN
 GREAT PLAINS BOULEVARD

CITY PROJECT	24-01	SHEET NO.	113
			188

C:\Users\REED~1\HED\AppData\Local\Temp\AcFubish_28308\2024_PaveRehab_P&P.dwg March 05, 2024 - 2:27pm

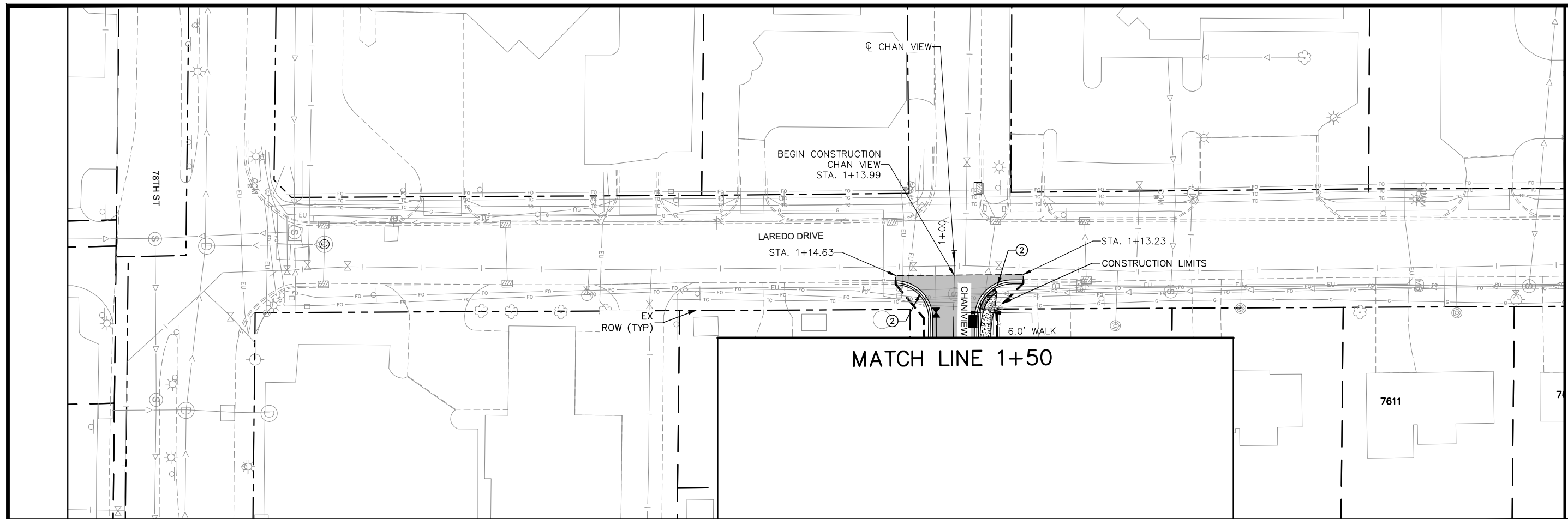

MATCH LINE
SEE NEXT SHEET

- LEGEND:**
- 2" BITUMINOUS MILL & OVERLAY (SEE INSET C)
 - FULL DEPTH RECLAMATION (SEE INSET B)
 - FULL DEPTH RECONSTRUCTION (SEE INSET A)
 - CONCRETE SIDEWALK (SEE INSET E)
 - 3" BITUMINOUS WALK (SEE INSET H)
 - TRUNCATED DOMES
 - CONCRETE DRIVEWAY REPLACEMENT (SEE INSET G)
 - BITUMINOUS DRIVEWAY REPLACEMENT (SEE INSET F)
 - PAVER DRIVEWAY REPLACEMENT
 - FULL DEPTH SAW CUT
 - CONSTRUCTION LIMITS
 - PROPOSED CURB & GUTTER
 - EXISTING RIGHT-OF-WAY
 - BID ALT MATCH LINE (SEE STATEMENT OF ESTIMATED QUANTITIES FOR DETAILS)

- GENERAL NOTES:**
1. ALL CURB IS SURMOUNTABLE CURB AND GUTTER, UNLESS OTHERWISE NOTED.
 2. ALL DIMENSIONS ARE FACE OF CURB UNLESS OTHERWISE NOTED
 3. ENGINEER TO IDENTIFY AND MARK LOCATIONS FOR CONCRETE WALK REPLACEMENT
 4. ENGINEER TO IDENTIFY AND MARK LOCATIONS FOR CONCRETE AND BITUMINOUS DRIVEWAY REPLACEMENTS.
- NOTES:**
- ① B618 CURB AND GUTTER
 - ② SEE CITY STANDARD PLATE 5204 FOR TYPICAL CURB RADIUS DETAILS.
 - ③ PEDESTRIAN CURB RAMP (SEE INTERSECTION DETAILS)
 - ④ CURB CUT, SEE DETAIL ON SHEET 111. SEE GRADING PLAN, SHEET 112 FOR DETAILS.

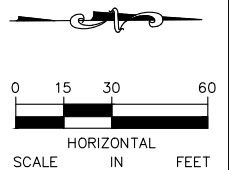

No.	Date	Revisions	App.

DRAWING NAME	2024_PaveRehab_P&P.dwg
DESIGNED BY:	MAK
DRAWN BY:	RCH
CHECKED BY:	MAK
DATE:	02/29/2024
PROJECT NO.	24-01

11995 SINGLETREE LANE, SUITE 225, EDEN PRAIRIE, MN 55344
 PHONE: 612-315-1272
 WWW.KIMLEY-HORN.COM

I HEREBY CERTIFY THAT THIS PLAN, SPECIFICATION OR REPORT WAS PREPARED BY ME OR UNDER MY DIRECT SUPERVISION AND THAT I AM A DULY LICENSED PROFESSIONAL ENGINEER UNDER THE LAWS OF THE STATE OF MINNESOTA.

Michael A. Kirsch
 MICHAEL A. KIRSCH
 DATE: 02/29/2024 MN LIC. NO. 59057



CITY OF CHANHASSEN
 2024 CITY PAVEMENT
 REHABILITATION PROJECT

CONSTRUCTION PLAN & PROFILE
 LAREDO DRIVE

CITY PROJECT	24-01
SHEET NO.	
117	

188

k:\TOW_Civil\CITY\CHANHASSEN\2024 CITY STREET REHAB-RECON\CAD\Plan Sheets\2024_PaveRehab_P&P.dwg February 29, 2024 -- 7:35pm

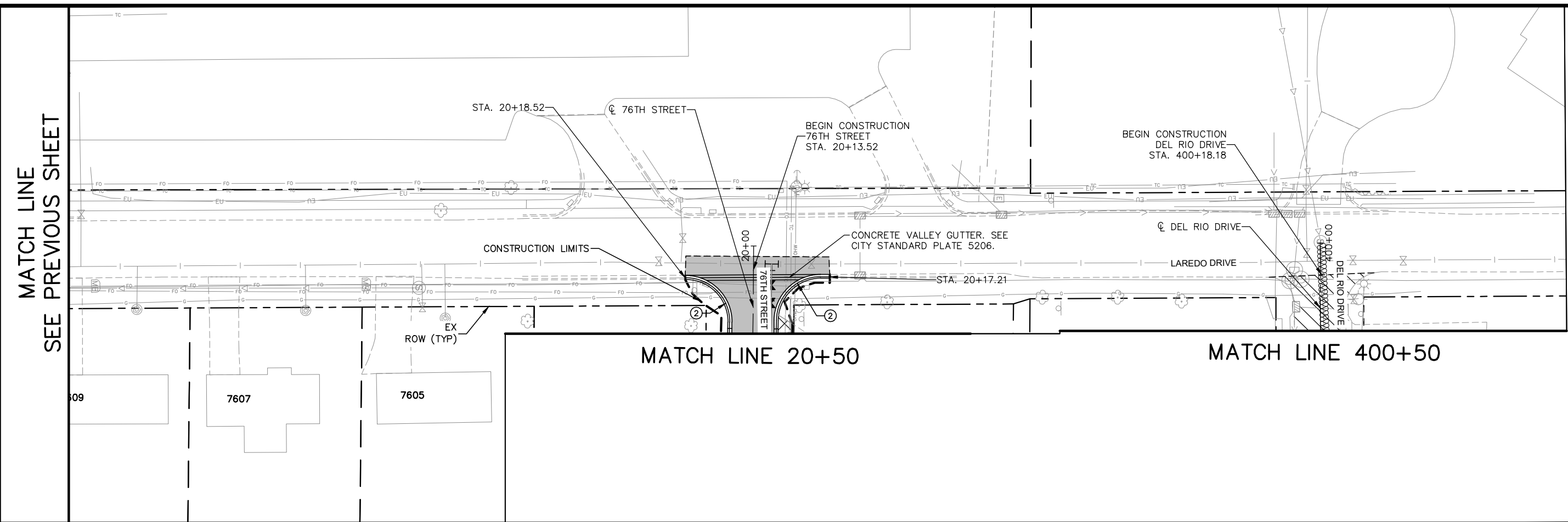

MATCH LINE
SEE PREVIOUS SHEET

MATCH LINE 20+50

MATCH LINE 400+50

LEGEND:

- 2" BITUMINOUS MILL & OVERLAY (SEE INSET C)
- FULL DEPTH RECLAMATION (SEE INSET B)
- FULL DEPTH RECONSTRUCTION (SEE INSET A)
- CONCRETE SIDEWALK (SEE INSET E)
- 3" BITUMINOUS WALK (SEE INSET H)
- TRUNCATED DOMES
- CONCRETE DRIVEWAY REPLACEMENT (SEE INSET G)
- BITUMINOUS DRIVEWAY REPLACEMENT (SEE INSET F)
- PAVER DRIVEWAY REPLACEMENT
- FULL DEPTH SAW CUT
- CONSTRUCTION LIMITS
- PROPOSED CURB & GUTTER
- EXISTING RIGHT-OF-WAY
- BID ALT MATCH LINE (SEE STATEMENT OF ESTIMATED QUANTITIES FOR DETAILS)

GENERAL NOTES:

1. ALL CURB IS SURMOUNTABLE CURB AND GUTTER, UNLESS OTHERWISE NOTED.
2. ALL DIMENSIONS ARE FACE OF CURB UNLESS OTHERWISE NOTED
3. ENGINEER TO IDENTIFY AND MARK LOCATIONS FOR CONCRETE WALK REPLACEMENT
4. ENGINEER TO IDENTIFY AND MARK LOCATIONS FOR CONCRETE AND BITUMINOUS DRIVEWAY REPLACEMENTS.

NOTES:

- ① B618 CURB AND GUTTER
- ② SEE CITY STANDARD PLATE 5204 FOR TYPICAL CURB RADIUS DETAILS.
- ③ PEDESTRIAN CURB RAMP (SEE INTERSECTION DETAILS)
- ④ CURB CUT, SEE DETAIL ON SHEET 111. SEE GRADING PLAN, SHEET 112 FOR DETAILS.

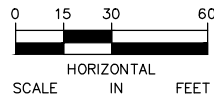

No.	Date	Revisions	App.

DRAWING NAME 2024_PaveRehab_P&P.dwg	DESIGNED BY: MAK
DRAWN BY: RCH	CHECKED BY: MAK
DATE: 02/29/2024	PROJECT NO. 24-01

11995 SINGLETREE LANE, SUITE 225, EDEN PRAIRIE, MN 55344
PHONE: 612-315-1272
WWW.KIMLEY-HORN.COM

I HEREBY CERTIFY THAT THIS PLAN, SPECIFICATION OR REPORT WAS PREPARED BY ME OR UNDER MY DIRECT SUPERVISION AND THAT I AM A DULY LICENSED PROFESSIONAL ENGINEER UNDER THE LAWS OF THE STATE OF MINNESOTA.

Michael A. Kirsch
MICHAEL A. KIRSCH
DATE: 02/29/2024 MN LIC. NO. 59057



CITY OF CHANHASSEN
2024 CITY PAVEMENT
REHABILITATION PROJECT

CONSTRUCTION PLAN & PROFILE
LAREDO DRIVE

CITY PROJECT	24-01
SHEET NO. 118	







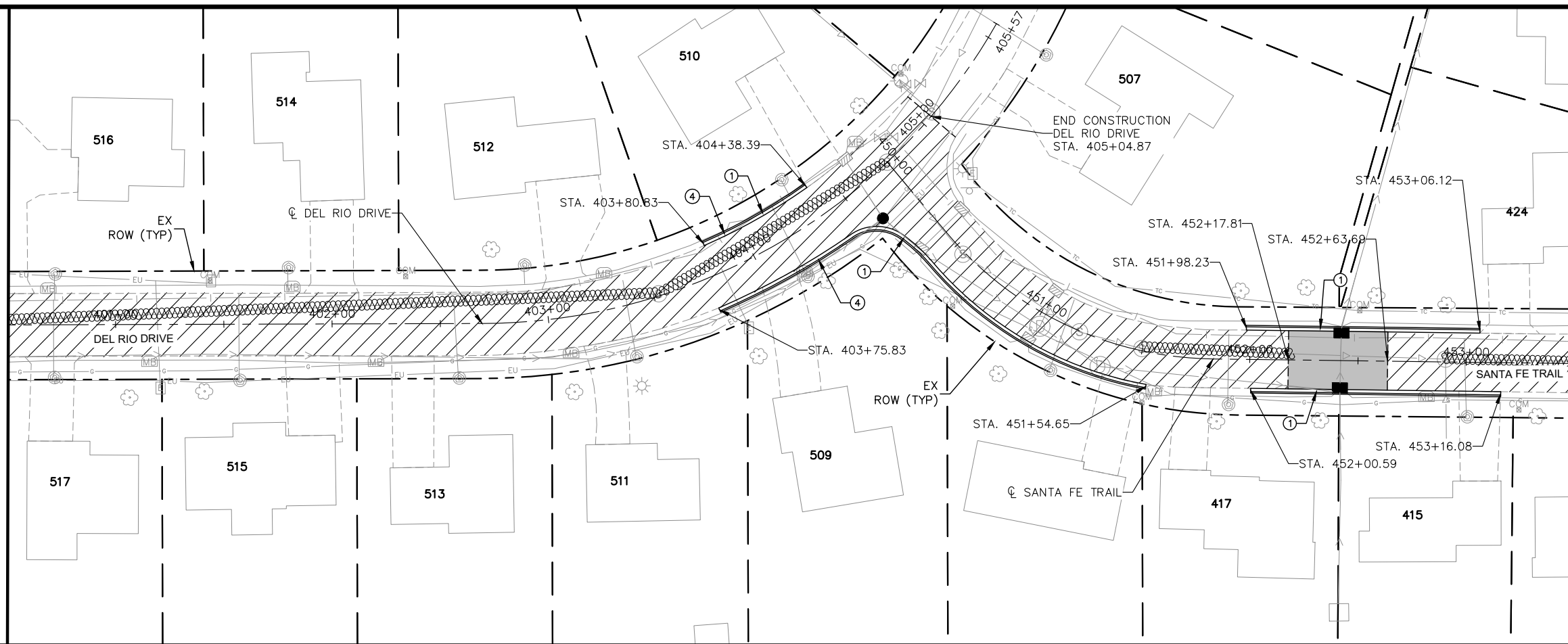

188

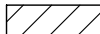
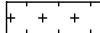
MATCH LINE 400+50

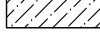
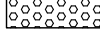
MATCH LINE 453+50

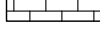
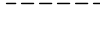

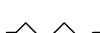
LEGEND:

-  2" BITUMINOUS MILL & OVERLAY (SEE INSET C)
-  FULL DEPTH RECLAMATION (SEE INSET B)
-  FULL DEPTH RECONSTRUCTION (SEE INSET A)
-  CONCRETE SIDEWALK (SEE INSET E)
-  3" BITUMINOUS WALK (SEE INSET H)
-  TRUNCTATED DOMES
-  CONCRETE DRIVEWAY REPLACEMENT (SEE INSET G)
-  BITUMINOUS DRIVEWAY REPLACEMENT (SEE INSET F)
-  PAVER DRIVEWAY REPLACEMENT
-  FULL DEPTH SAW CUT
-  CONSTRUCTION LIMITS
-  PROPOSED CURB & GUTTER
-  EXISTING RIGHT-OF-WAY
-  BID ALT MATCH LINE (SEE STATEMENT OF ESTIMATED QUANTITIES FOR DETAILS)

- GENERAL NOTES:**
1. ALL CURB IS SURMOUNTABLE CURB AND GUTTER, UNLESS OTHERWISE NOTED.
 2. ALL DIMENSIONS ARE FACE OF CURB UNLESS OTHERWISE NOTED
 3. ENGINEER TO IDENTIFY AND MARK LOCATIONS FOR CONCRETE WALK REPLACEMENT
 4. ENGINEER TO IDENTIFY AND MARK LOCATIONS FOR CONCRETE AND BITUMINOUS DRIVEWAY REPLACEMENTS.

- NOTES:**
- ① B618 CURB AND GUTTER
 - ② SEE CITY STANDARD PLATE 5204 FOR TYPICAL CURB RADIUS DETAILS.
 - ③ PEDESTRIAN CURB RAMP (SEE INTERSECTION DETAILS)
 - ④ CURB CUT, SEE DETAIL ON SHEET 111. SEE GRADING PLAN, SHEET 112 FOR DETAILS.

k:\TCW_Civil\CITY\CHANHASSEN\2024 CITY STREET REHAB-RECONSTRUCT\CAD\Plan Sheets\2024_PaveRehab_P&P.dwg February 29, 2024 - 6:44pm

No.	Date	Revisions	App.

DRAWING NAME	2024_PaveRehab_P&P.dwg
DESIGNED BY:	MAK
DRAWN BY:	RCH
CHECKED BY:	MAK
DATE:	02/29/2024
PROJECT NO.	24-01

Kimley»Horn

11995 SINGLETREE LANE, SUITE 225, EDEN PRAIRIE, MN 55344
 PHONE: 612-315-1272
 WWW.KIMLEY-HORN.COM

I HEREBY CERTIFY THAT THIS PLAN, SPECIFICATION OR REPORT WAS PREPARED BY ME OR UNDER MY DIRECT SUPERVISION AND THAT I AM A DULY LICENSED PROFESSIONAL ENGINEER UNDER THE LAWS OF THE STATE OF MINNESOTA.

Michael A. Kirsch
 MICHAEL A. KIRSCH
 DATE: 02/29/2024 MN LIC. NO. 59057



CITY OF CHANHASSEN
 2024 CITY PAVEMENT
 REHABILITATION PROJECT

CONSTRUCTION PLAN & PROFILE
 DEL RIO DR AND SANTA FE TRAIL
 STA. 400+50 TO STA. 543+50

CITY PROJECT 24-01

SHEET NO.
119
188

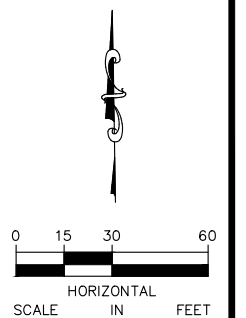

k:\TCW_Civil\CITY\CHANHASSEN\2024 CITY STREET REHAB-RECON\2024_PaveRehab_P&P.dwg February 29, 2024 - 6:44pm

MATCH LINE 543+50

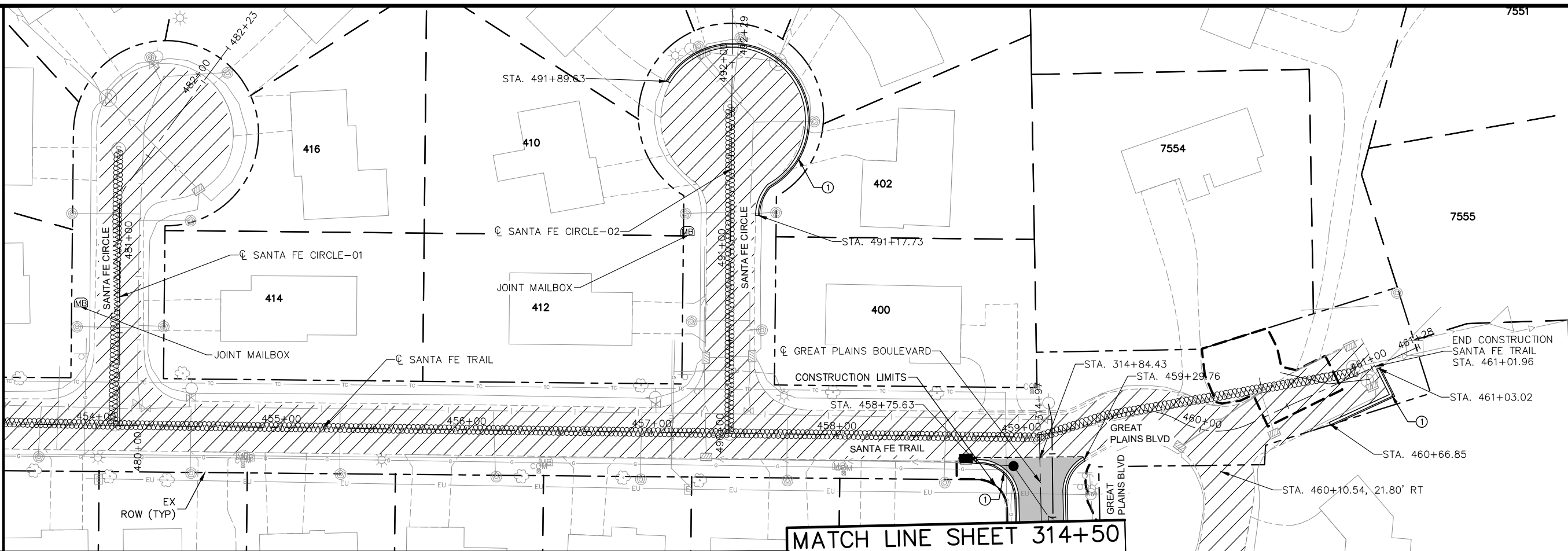

MATCH LINE SHEET 314+50

LEGEND:

	2" BITUMINOUS MILL & OVERLAY (SEE INSET C)
	FULL DEPTH RECLAMATION (SEE INSET B)
	FULL DEPTH RECONSTRUCTION (SEE INSET A)
	CONCRETE SIDEWALK (SEE INSET E)
	3" BITUMINOUS WALK (SEE INSET H)
	TRUNCATED DOMES
	CONCRETE DRIVEWAY REPLACEMENT (SEE INSET G)
	BITUMINOUS DRIVEWAY REPLACEMENT (SEE INSET F)
	PAVER DRIVEWAY REPLACEMENT
	FULL DEPTH SAW CUT
	CONSTRUCTION LIMITS
	PROPOSED CURB & GUTTER
	EXISTING RIGHT-OF-WAY
	BID ALT MATCH LINE (SEE STATEMENT OF ESTIMATED QUANTITIES FOR DETAILS)

- GENERAL NOTES:**
1. ALL CURB IS SURMOUNTABLE CURB AND GUTTER, UNLESS OTHERWISE NOTED.
 2. ALL DIMENSIONS ARE FACE OF CURB UNLESS OTHERWISE NOTED.
 3. ENGINEER TO IDENTIFY AND MARK LOCATIONS FOR CONCRETE WALK REPLACEMENT
 4. ENGINEER TO IDENTIFY AND MARK LOCATIONS FOR CONCRETE AND BITUMINOUS DRIVEWAY REPLACEMENTS.
- NOTES:**
- ① B618 CURB AND GUTTER
 - ② SEE CITY STANDARD PLATE 5204 FOR TYPICAL CURB RADIUS DETAILS.
 - ③ PEDESTRIAN CURB RAMP (SEE INTERSECTION DETAILS)
 - ④ CURB CUT, SEE DETAIL ON SHEET 111. SEE GRADING PLAN, SHEET 112 FOR DETAILS.

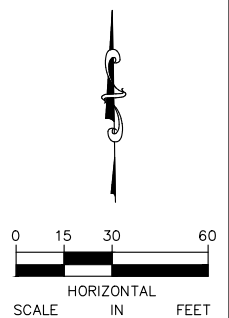

No.	Date	Revisions	App.

DRAWING NAME	2024_PaveRehab_P&P.dwg
DESIGNED BY:	MAK
DRAWN BY:	RCH
CHECKED BY:	MAK
DATE:	02/29/2024
PROJECT NO.	24-01

Kimley»Horn

11995 SINGLETREE LANE, SUITE 225, EDEN PRAIRIE, MN 55344
 PHONE: 612-315-1272
 WWW.KIMLEY-HORN.COM

I HEREBY CERTIFY THAT THIS PLAN, SPECIFICATION OR REPORT WAS PREPARED BY ME OR UNDER MY DIRECT SUPERVISION AND THAT I AM A DULY LICENSED PROFESSIONAL ENGINEER UNDER THE LAWS OF THE STATE OF MINNESOTA.

Michael A. Kirsch
 MICHAEL A. KIRSCH
 DATE: 02/29/2024 MN LIC. NO. 59057



CITY OF CHANHASSEN
 2024 CITY PAVEMENT
 REHABILITATION PROJECT

CONSTRUCTION PLAN & PROFILE
 DEL RIO DR AND SANTA FE TRAIL
 STA. 543+50 TO STA. 459+14

CITY PROJECT	24-01
SHEET NO.	120
188	

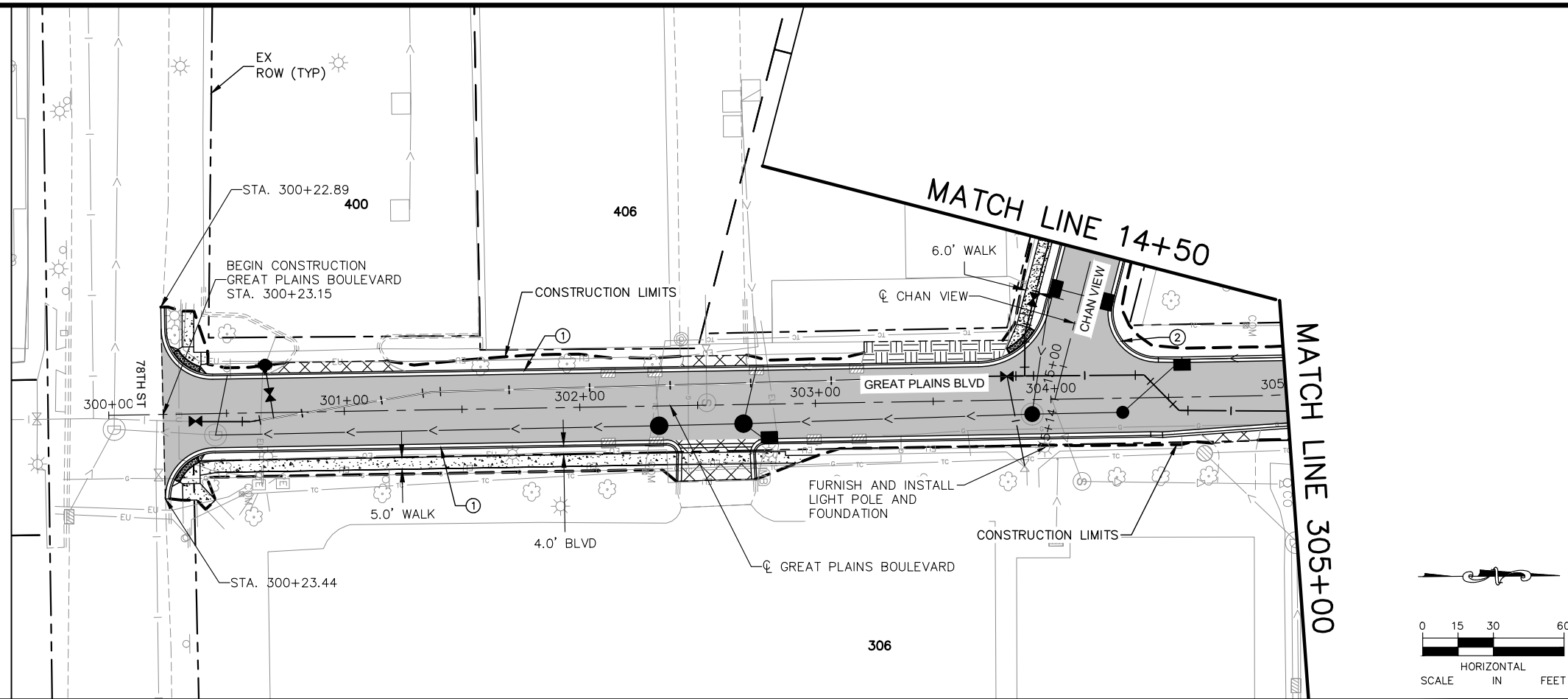

- LEGEND:**
- 2" BITUMINOUS MILL & OVERLAY (SEE INSET C)
 - FULL DEPTH RECLAMATION (SEE INSET B)
 - FULL DEPTH RECONSTRUCTION (SEE INSET A)
 - CONCRETE SIDEWALK (SEE INSET E)
 - 3" BITUMINOUS WALK (SEE INSET H)
 - TRUNCATED DOMES
 - CONCRETE DRIVEWAY REPLACEMENT (SEE INSET G)
 - BITUMINOUS DRIVEWAY REPLACEMENT (SEE INSET F)
 - PAVER DRIVEWAY REPLACEMENT
 - FULL DEPTH SAW CUT
 - CONSTRUCTION LIMITS
 - PROPOSED CURB & GUTTER
 - EXISTING RIGHT-OF-WAY
 - BID ALT MATCH LINE (SEE STATEMENT OF ESTIMATED QUANTITIES FOR DETAILS)

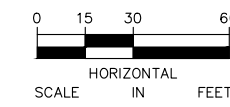
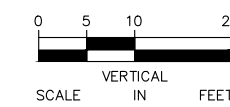
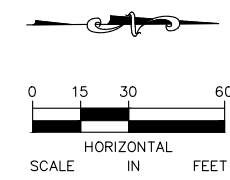

- GENERAL NOTES:**
1. ALL CURB IS SURMOUNTABLE CURB AND GUTTER, UNLESS OTHERWISE NOTED.
 2. ALL DIMENSIONS ARE FACE OF CURB UNLESS OTHERWISE NOTED
 3. ENGINEER TO IDENTIFY AND MARK LOCATIONS FOR CONCRETE WALK REPLACEMENT
 4. ENGINEER TO IDENTIFY AND MARK LOCATIONS FOR CONCRETE AND BITUMINOUS DRIVEWAY REPLACEMENTS.

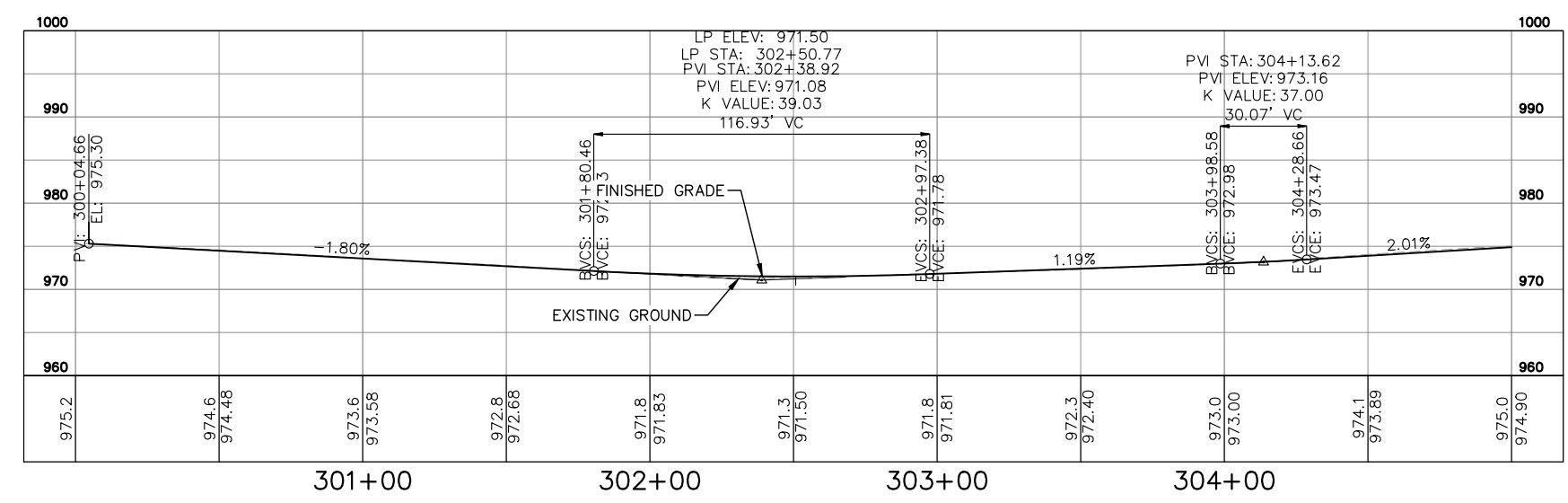

- NOTES:**
- ① B618 CURB AND GUTTER
 - ② SEE CITY STANDARD PLATE 5204 FOR TYPICAL CURB RADIUS DETAILS.
 - ③ PEDESTRIAN CURB RAMP (SEE INTERSECTION DETAILS)
 - ④ CURB CUT, SEE DETAIL ON SHEET 111. SEE GRADING PLAN, SHEET 112 FOR DETAILS.

C:\Users\REED~1\HED\AppData\Local\Temp\AcFubish_28308\2024_PaveRehab_P&P.dwg March 05, 2024 - 2:33pm

No.	Date	Revisions	App.	DRAWING NAME
				2024_PaveRehab_P&P.dwg
				DESIGNED BY: MAK
				DRAWN BY: RCH
				CHECKED BY: MAK
				DATE: 02/29/2024
				PROJECT NO. 24-01

Kimley»Horn

11995 SINGLETREE LANE, SUITE 225, EDEN PRAIRIE, MN 55344
PHONE: 612-315-1272
WWW.KIMLEY-HORN.COM

I HEREBY CERTIFY THAT THIS PLAN, SPECIFICATION OR REPORT WAS PREPARED BY ME OR UNDER MY DIRECT SUPERVISION AND THAT I AM A DULY LICENSED PROFESSIONAL ENGINEER UNDER THE LAWS OF THE STATE OF MINNESOTA.

Michael A. Kirsch
MICHAEL A. KIRSCH
DATE: 02/29/2024 MN LIC. NO. 59057



CITY OF CHANHASSEN
2024 CITY PAVEMENT
REHABILITATION PROJECT

CONSTRUCTION PLAN & PROFILE
GREAT PLAINS BOULEVARD
STA. 300+00 TO STA. 305+00

CITY PROJECT	24-01	SHEET NO.
		121
		188

k:\TOW_Civil\CITY\CHANHASSEN\2024 CITY STREET REHAB-RECONSTRUCT\CAD\Plan Sheets\2024_PaveRehab_P&P.dwg February 29, 2024 - 6:44pm

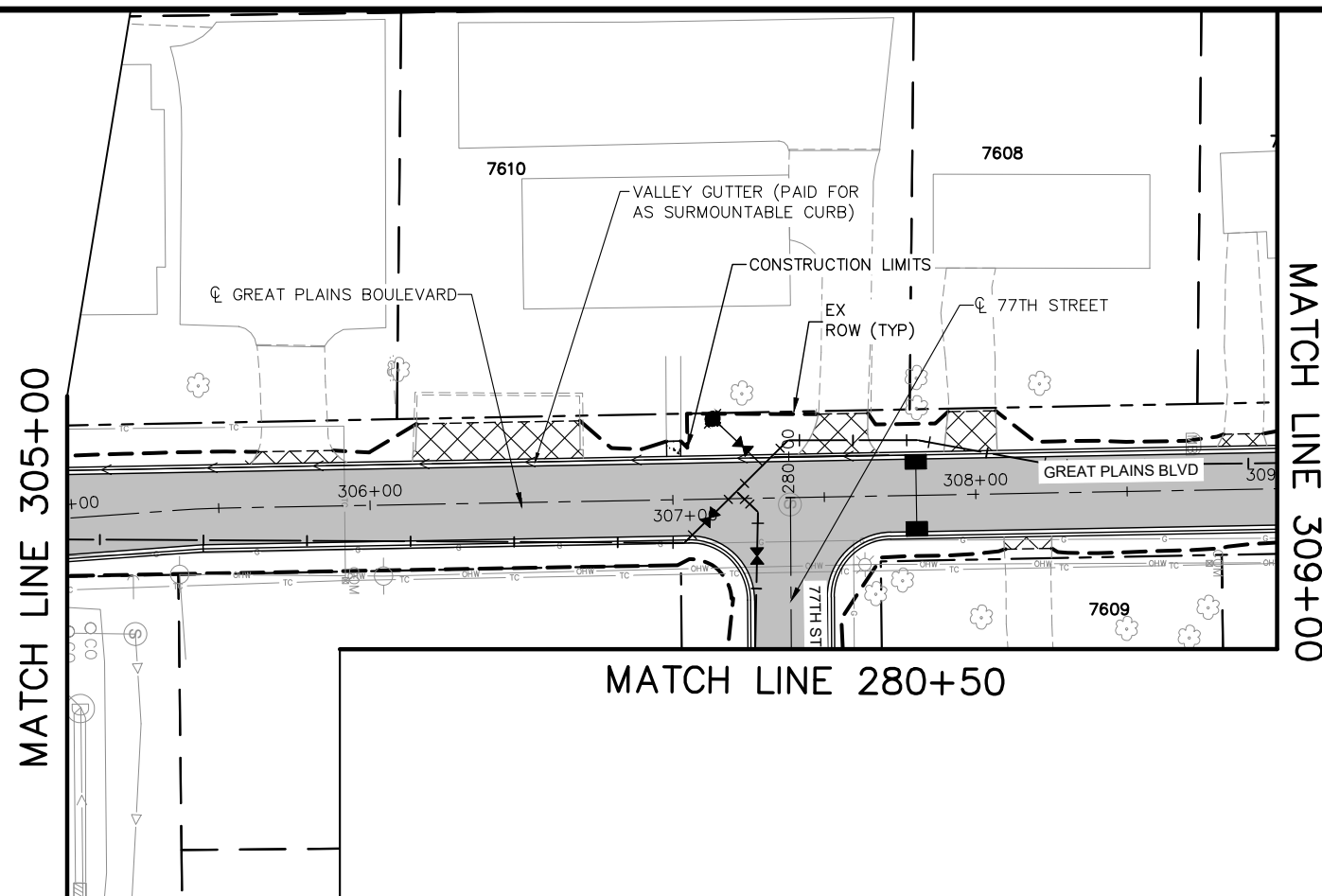

- LEGEND:**
- 2" BITUMINOUS MILL & OVERLAY (SEE INSET C)
 - FULL DEPTH RECLAMATION (SEE INSET B)
 - FULL DEPTH RECONSTRUCTION (SEE INSET A)
 - CONCRETE SIDEWALK (SEE INSET E)
 - 3" BITUMINOUS WALK (SEE INSET H)
 - TRUNCATED DOMES
 - CONCRETE DRIVEWAY REPLACEMENT (SEE INSET G)
 - BITUMINOUS DRIVEWAY REPLACEMENT (SEE INSET F)
 - PAVER DRIVEWAY REPLACEMENT
 - FULL DEPTH SAW CUT
 - CONSTRUCTION LIMITS
 - PROPOSED CURB & GUTTER
 - EXISTING RIGHT-OF-WAY
 - BID ALT MATCH LINE (SEE STATEMENT OF ESTIMATED QUANTITIES FOR DETAILS)

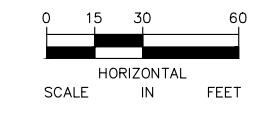
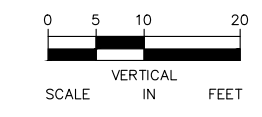
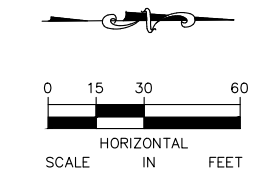

- GENERAL NOTES:**
1. ALL CURB IS SURMOUNTABLE CURB AND GUTTER, UNLESS OTHERWISE NOTED.
 2. ALL DIMENSIONS ARE FACE OF CURB UNLESS OTHERWISE NOTED
 3. ENGINEER TO IDENTIFY AND MARK LOCATIONS FOR CONCRETE WALK REPLACEMENT
 4. ENGINEER TO IDENTIFY AND MARK LOCATIONS FOR CONCRETE AND BITUMINOUS DRIVEWAY REPLACEMENTS.

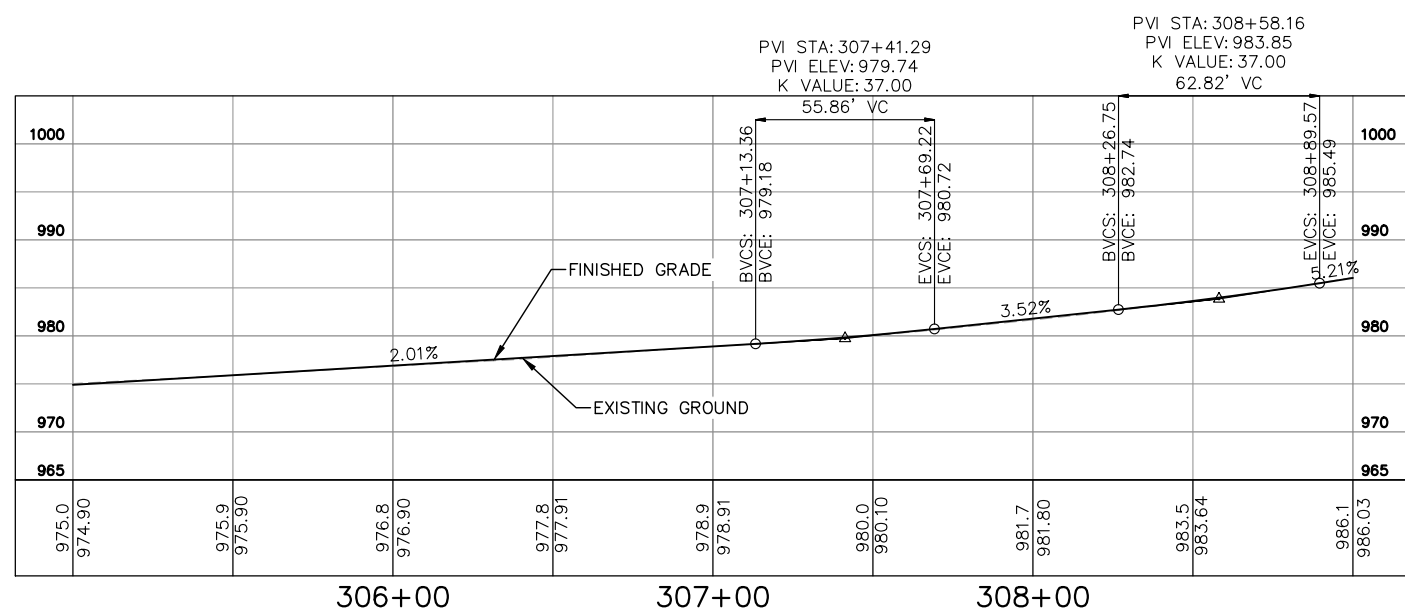

No.	Date	Revisions	App.

DRAWING NAME	2024_PaveRehab_P&P.dwg
DESIGNED BY:	MAK
DRAWN BY:	RCH
CHECKED BY:	MAK
DATE:	02/29/2024
PROJECT NO.	24-01

Kimley»Horn

11995 SINGLETREE LANE, SUITE 225, EDEN PRAIRIE, MN 55344
 PHONE: 612-315-1272
 WWW.KIMLEY-HORN.COM

I HEREBY CERTIFY THAT THIS PLAN, SPECIFICATION OR REPORT WAS PREPARED BY ME OR UNDER MY DIRECT SUPERVISION AND THAT I AM A DULY LICENSED PROFESSIONAL ENGINEER UNDER THE LAWS OF THE STATE OF MINNESOTA.

Michael A. Kirsch
 MICHAEL A. KIRSCH
 DATE: 02/29/2024 MN LIC. NO. 59057



CITY OF CHANHASSEN
 2024 CITY PAVEMENT
 REHABILITATION PROJECT

CONSTRUCTION PLAN & PROFILE
 GREAT PLAINS BOULEVARD
 STA. 305+00 TO STA. 309+00

CITY PROJECT	24-01	SHEET NO.	122
		188	

k:\TOW_Civil\CITY\CHANHASSEN\2024 CITY STREET REHAB-RECONSTRUCT\CAD\Plan Sheets\2024_PaveRehab_P&P.dwg February 29, 2024 - 6:44pm

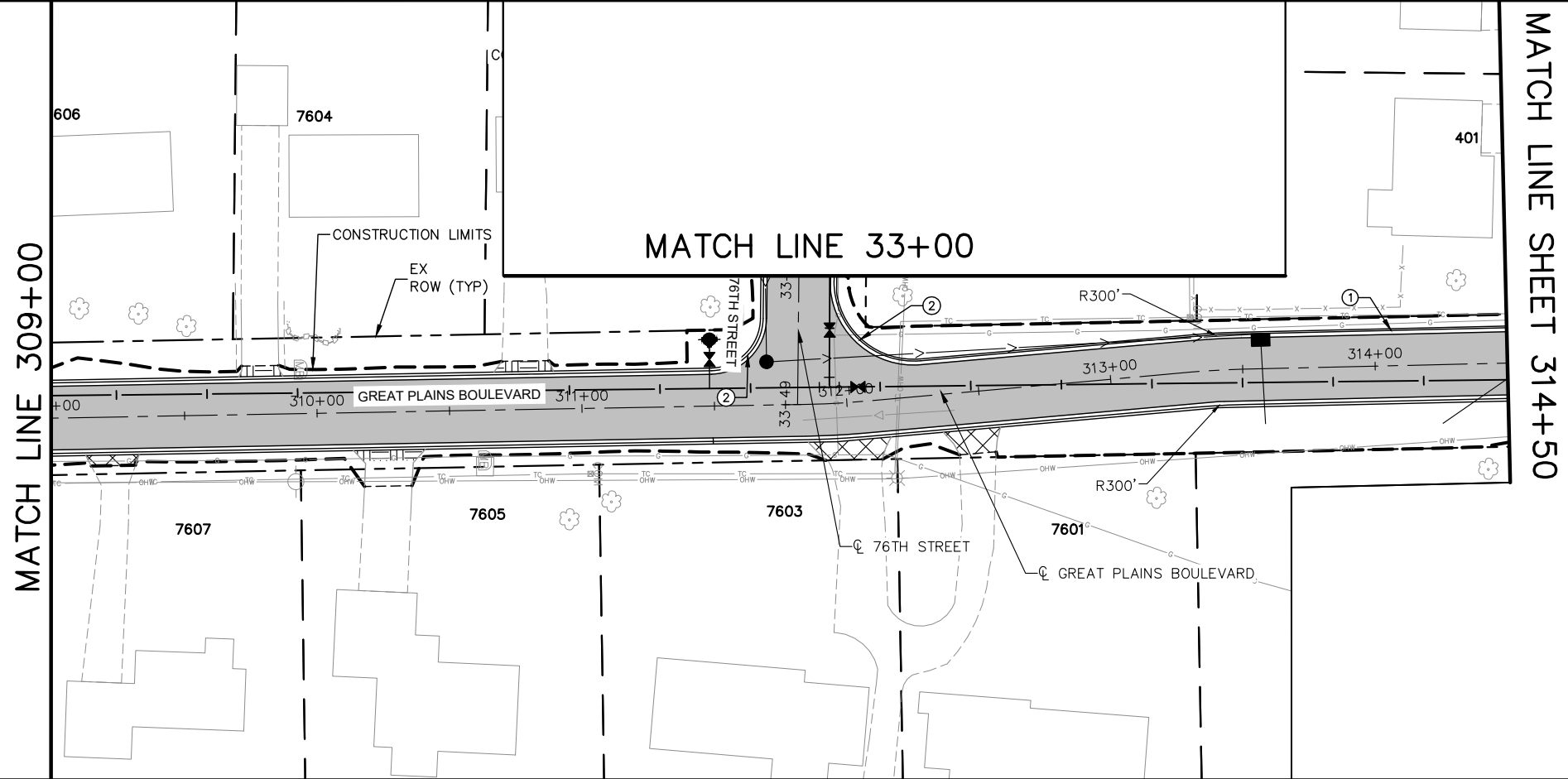

- LEGEND:**
- 2" BITUMINOUS MILL & OVERLAY (SEE INSET C)
 - FULL DEPTH RECLAMATION (SEE INSET B)
 - FULL DEPTH RECONSTRUCTION (SEE INSET A)
 - CONCRETE SIDEWALK (SEE INSET E)
 - 3" BITUMINOUS WALK (SEE INSET H)
 - TRUNCTATED DOMES
 - CONCRETE DRIVEWAY REPLACEMENT (SEE INSET G)
 - BITUMINOUS DRIVEWAY REPLACEMENT (SEE INSET F)
 - PAVER DRIVEWAY REPLACEMENT
 - FULL DEPTH SAW CUT
 - CONSTRUCTION LIMITS
 - PROPOSED CURB & GUTTER
 - EXISTING RIGHT-OF-WAY
 - BID ALT MATCH LINE (SEE STATEMENT OF ESTIMATED QUANTITIES FOR DETAILS)

- GENERAL NOTES:**
1. ALL CURB IS SURMOUNTABLE CURB AND GUTTER, UNLESS OTHERWISE NOTED.
 2. ALL DIMENSIONS ARE FACE OF CURB UNLESS OTHERWISE NOTED
 3. ENGINEER TO IDENTIFY AND MARK LOCATIONS FOR CONCRETE WALK REPLACEMENT
 4. ENGINEER TO IDENTIFY AND MARK LOCATIONS FOR CONCRETE AND BITUMINOUS DRIVEWAY REPLACEMENTS.

- NOTES:**
- ① B618 CURB AND GUTTER
 - ② SEE CITY STANDARD PLATE 5204 FOR TYPICAL CURB RADIUS DETAILS.
 - ③ PEDESTRIAN CURB RAMP (SEE INTERSECTION DETAILS)
 - ④ CURB CUT, SEE DETAIL ON SHEET 111. SEE GRADING PLAN, SHEET 112 FOR DETAILS.

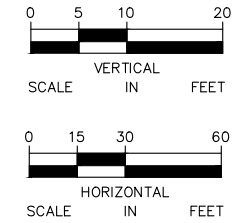

No.	Date	Revisions	App.

DRAWING NAME	2024_PaveRehab_P&P.dwg
DESIGNED BY:	MAK
DRAWN BY:	RCH
CHECKED BY:	MAK
DATE:	02/29/2024
PROJECT NO.	24-01

Kimley»Horn

11995 SINGLETREE LANE, SUITE 225, EDEN PRAIRIE, MN 55344
 PHONE: 612-315-1272
 WWW.KIMLEY-HORN.COM

I HEREBY CERTIFY THAT THIS PLAN, SPECIFICATION OR REPORT WAS PREPARED BY ME OR UNDER MY DIRECT SUPERVISION AND THAT I AM A DULY LICENSED PROFESSIONAL ENGINEER UNDER THE LAWS OF THE STATE OF MINNESOTA.

Michael A. Kirsch
 MICHAEL A. KIRSCH
 DATE: 02/29/2024 MN LIC. NO. 59057



CITY OF CHANHASSEN
 2024 CITY PAVEMENT
 REHABILITATION PROJECT

CONSTRUCTION PLAN & PROFILE
 GREAT PLAINS BOULEVARD
 STA. 309+00 TO STA. 314+50

CITY PROJECT 24-01

SHEET NO.
123
188

k:\TOW_Civil\CITY\CHANHASSEN\2024 CITY STREET REHAB-RECON\CAD\Plan Sheets\2024_PaveRehab_P&P.dwg February 29, 2024 - 6:45pm

MATCH LINE 20+50

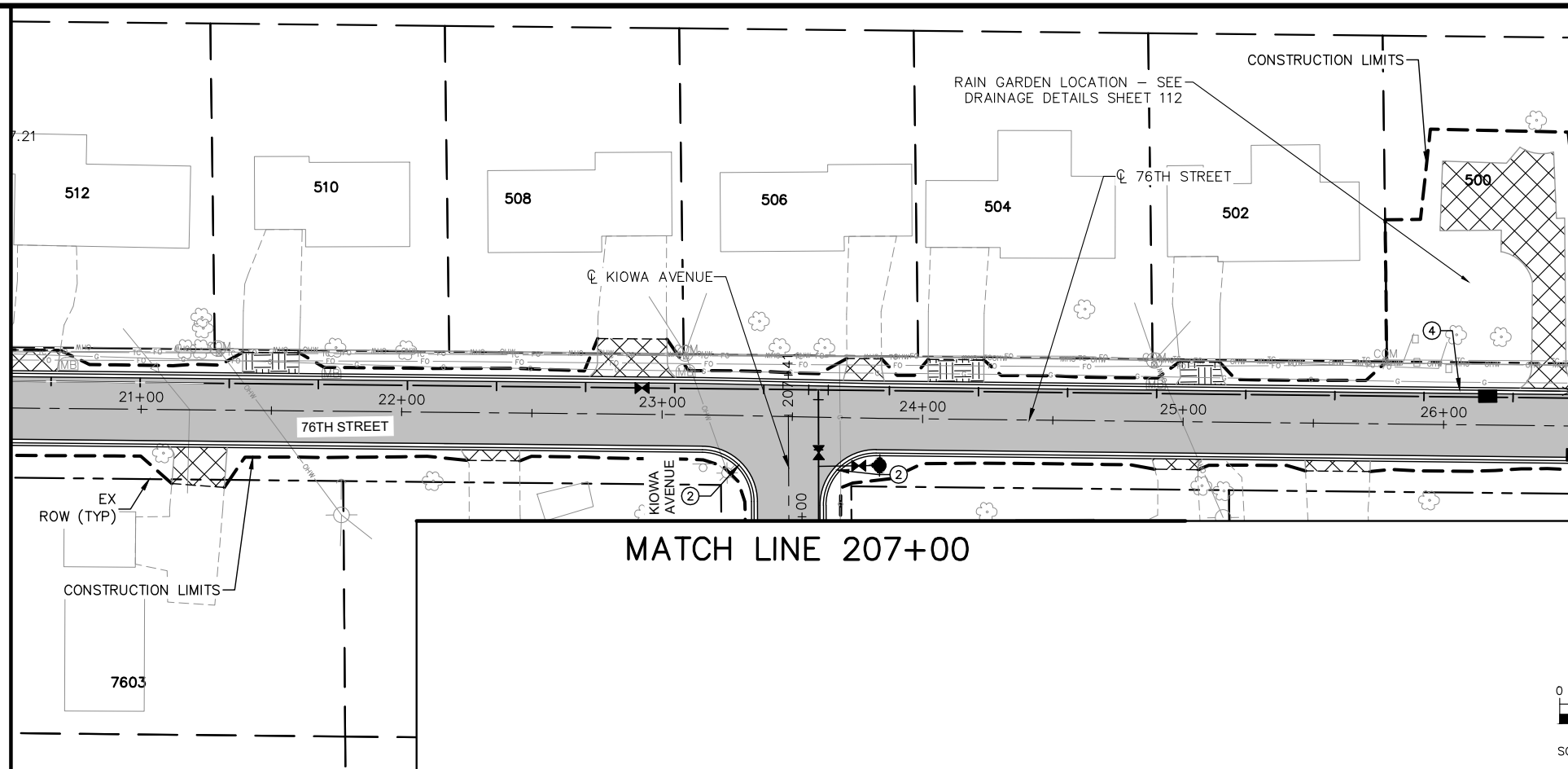

MATCH LINE 26+50

LEGEND:

- 2" BITUMINOUS MILL & OVERLAY (SEE INSET C)
- FULL DEPTH RECLAMATION (SEE INSET B)
- FULL DEPTH RECONSTRUCTION (SEE INSET A)
- CONCRETE SIDEWALK (SEE INSET E)
- 3" BITUMINOUS WALK (SEE INSET H)
- TRUNCTATED DOMES
- CONCRETE DRIVEWAY REPLACEMENT (SEE INSET G)
- BITUMINOUS DRIVEWAY REPLACEMENT (SEE INSET F)
- PAVER DRIVEWAY REPLACEMENT
- FULL DEPTH SAW CUT
- CONSTRUCTION LIMITS
- PROPOSED CURB & GUTTER
- EXISTING RIGHT-OF-WAY
- BID ALT MATCH LINE (SEE STATEMENT OF ESTIMATED QUANTITIES FOR DETAILS)

GENERAL NOTES:

1. ALL CURB IS SURMOUNTABLE CURB AND GUTTER, UNLESS OTHERWISE NOTED.
2. ALL DIMENSIONS ARE FACE OF CURB UNLESS OTHERWISE NOTED.
3. ENGINEER TO IDENTIFY AND MARK LOCATIONS FOR CONCRETE WALK REPLACEMENT.
4. ENGINEER TO IDENTIFY AND MARK LOCATIONS FOR CONCRETE AND BITUMINOUS DRIVEWAY REPLACEMENTS.

NOTES:

- ① B618 CURB AND GUTTER
- ② SEE CITY STANDARD PLATE 5204 FOR TYPICAL CURB RADIUS DETAILS.
- ③ PEDESTRIAN CURB RAMP (SEE INTERSECTION DETAILS)
- ④ CURB CUT, SEE DETAIL ON SHEET 111. SEE GRADING PLAN, SHEET 112 FOR DETAILS.

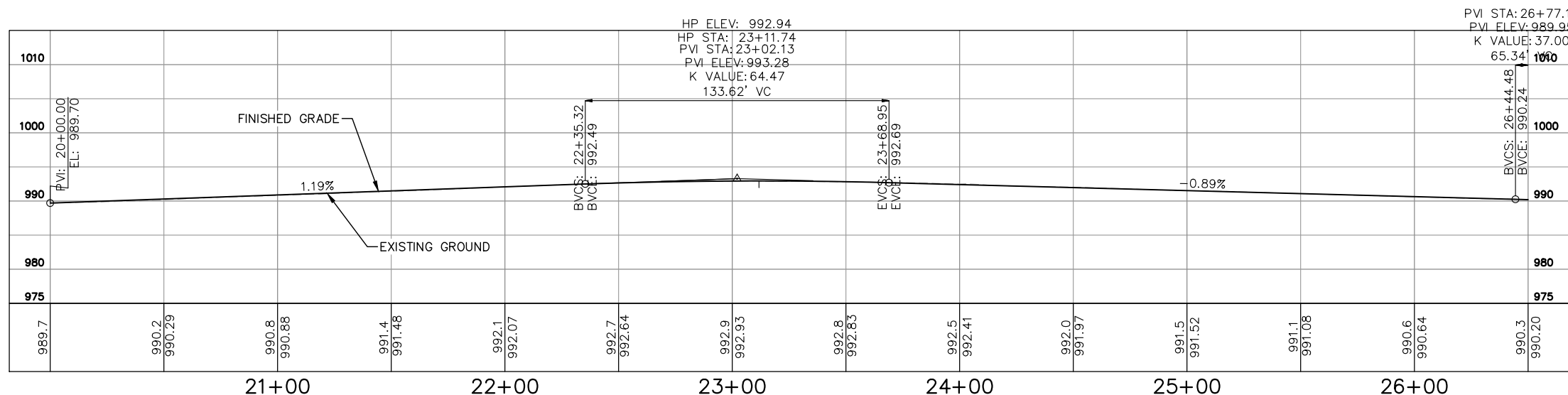
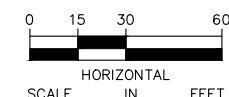
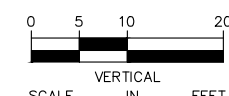
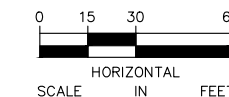

No.	Date	Revisions	App.	DRAWING NAME
				2024_PaveRehab_P&P.dwg
				DESIGNED BY: MAK
				DRAWN BY: RCH
				CHECKED BY: MAK
				DATE: 02/29/2024
				PROJECT NO. 24-01

Kimley»Horn

11995 SINGLETREE LANE, SUITE 225, EDEN PRAIRIE, MN 55344
 PHONE: 612-315-1272
 WWW.KIMLEY-HORN.COM

I HEREBY CERTIFY THAT THIS PLAN, SPECIFICATION OR REPORT WAS PREPARED BY ME OR UNDER MY DIRECT SUPERVISION AND THAT I AM A DULY LICENSED PROFESSIONAL ENGINEER UNDER THE LAWS OF THE STATE OF MINNESOTA.

Michael A. Kirsch
 MICHAEL A. KIRSCH
 DATE: 02/29/2024 MN LIC. NO. 59057

CITY OF CHANHASSEN
 2024 CITY PAVEMENT
 REHABILITATION PROJECT

CONSTRUCTION PLAN & PROFILE
 76TH STREET
 STA. 20+50 TO STA. 26+50

CITY PROJECT	24-01	SHEET NO.	124
		188	

k:\TOW_Civil\CITY\CHANHASSEN\2024 CITY STREET REHAB-RECON\2024_PaveRehab_P&P.dwg February 29, 2024 - 6:45pm

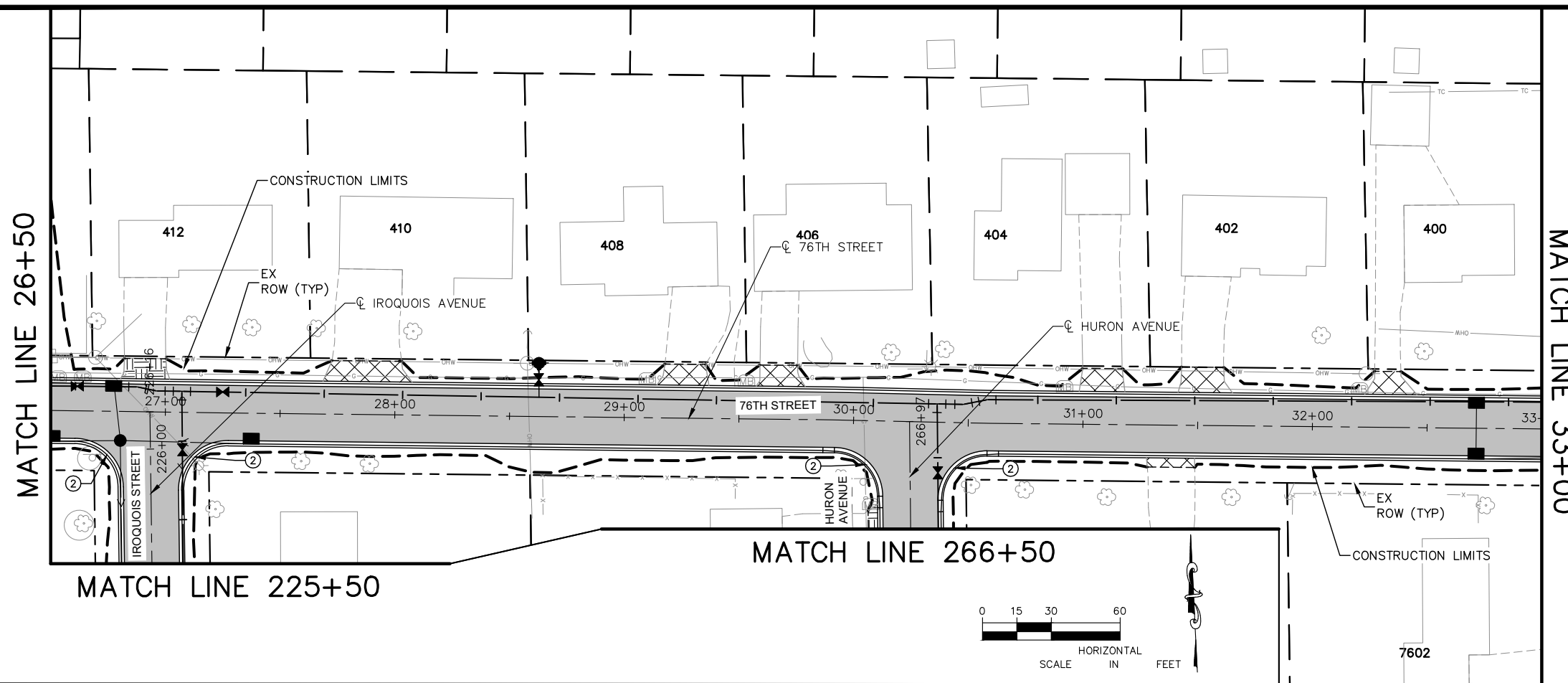

- LEGEND:**
- 2" BITUMINOUS MILL & OVERLAY (SEE INSET C)
 - FULL DEPTH RECLAMATION (SEE INSET B)
 - FULL DEPTH RECONSTRUCTION (SEE INSET A)
 - CONCRETE SIDEWALK (SEE INSET E)
 - 3" BITUMINOUS WALK (SEE INSET H)
 - TRUNCATED DOMES
 - CONCRETE DRIVEWAY REPLACEMENT (SEE INSET G)
 - BITUMINOUS DRIVEWAY REPLACEMENT (SEE INSET F)
 - PAVER DRIVEWAY REPLACEMENT
 - FULL DEPTH SAW CUT
 - CONSTRUCTION LIMITS
 - PROPOSED CURB & GUTTER
 - EXISTING RIGHT-OF-WAY
 - BID ALT MATCH LINE (SEE STATEMENT OF ESTIMATED QUANTITIES FOR DETAILS)

- GENERAL NOTES:**
1. ALL CURB IS SURMOUNTABLE CURB AND GUTTER, UNLESS OTHERWISE NOTED.
 2. ALL DIMENSIONS ARE FACE OF CURB UNLESS OTHERWISE NOTED
 3. ENGINEER TO IDENTIFY AND MARK LOCATIONS FOR CONCRETE WALK REPLACEMENT
 4. ENGINEER TO IDENTIFY AND MARK LOCATIONS FOR CONCRETE AND BITUMINOUS DRIVEWAY REPLACEMENTS.

- NOTES:**
- ① B618 CURB AND GUTTER
 - ② SEE CITY STANDARD PLATE 5204 FOR TYPICAL CURB RADIUS DETAILS.
 - ③ PEDESTRIAN CURB RAMP (SEE INTERSECTION DETAILS)
 - ④ CURB CUT, SEE DETAIL ON SHEET 111. SEE GRADING PLAN, SHEET 112 FOR DETAILS.

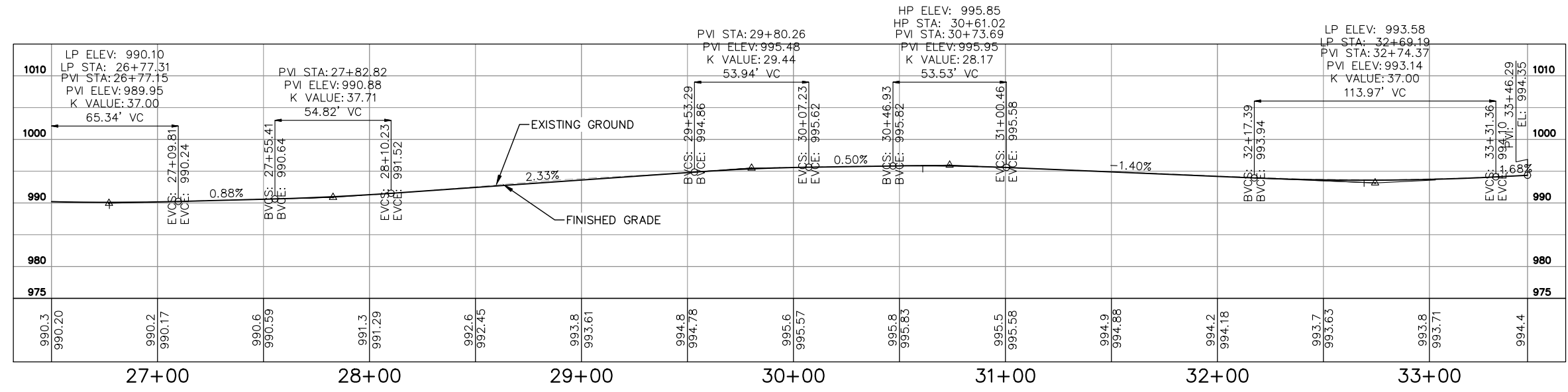
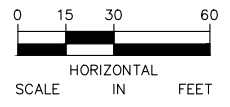
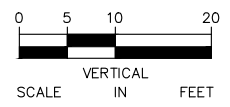
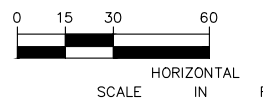

No.	Date	Revisions

App.	DRAWING NAME 2024_PaveRehab_P&P.dwg
	DESIGNED BY: MAK
	DRAWN BY: RCH
	CHECKED BY: MAK
	DATE: 02/29/2024
	PROJECT NO. 24-01

Kimley»Horn

11995 SINGLETREE LANE, SUITE 225, EDEN PRAIRIE, MN 55344
 PHONE: 612-315-1272
 WWW.KIMLEY-HORN.COM

I HEREBY CERTIFY THAT THIS PLAN, SPECIFICATION OR REPORT WAS PREPARED BY ME OR UNDER MY DIRECT SUPERVISION AND THAT I AM A DULY LICENSED PROFESSIONAL ENGINEER UNDER THE LAWS OF THE STATE OF MINNESOTA.

Michael A. Kirsch
 MICHAEL A. KIRSCH
 DATE: 02/29/2024 MN LIC. NO. 59057



CITY OF CHANHASSEN
 2024 CITY PAVEMENT
 REHABILITATION PROJECT

CONSTRUCTION PLAN & PROFILE
 76TH STREET
 STA. 26+50 TO STA. 33+00

CITY PROJECT	24-01
--------------	-------

SHEET NO.
125

188

C:\Users\REED\OneDrive\AppData\Local\Temp\AcPublish_28308\2024_PaveRehab_P&P.dwg March 05, 2024 - 2:29pm

MATCH LINE 1+50

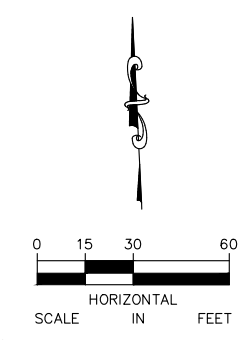
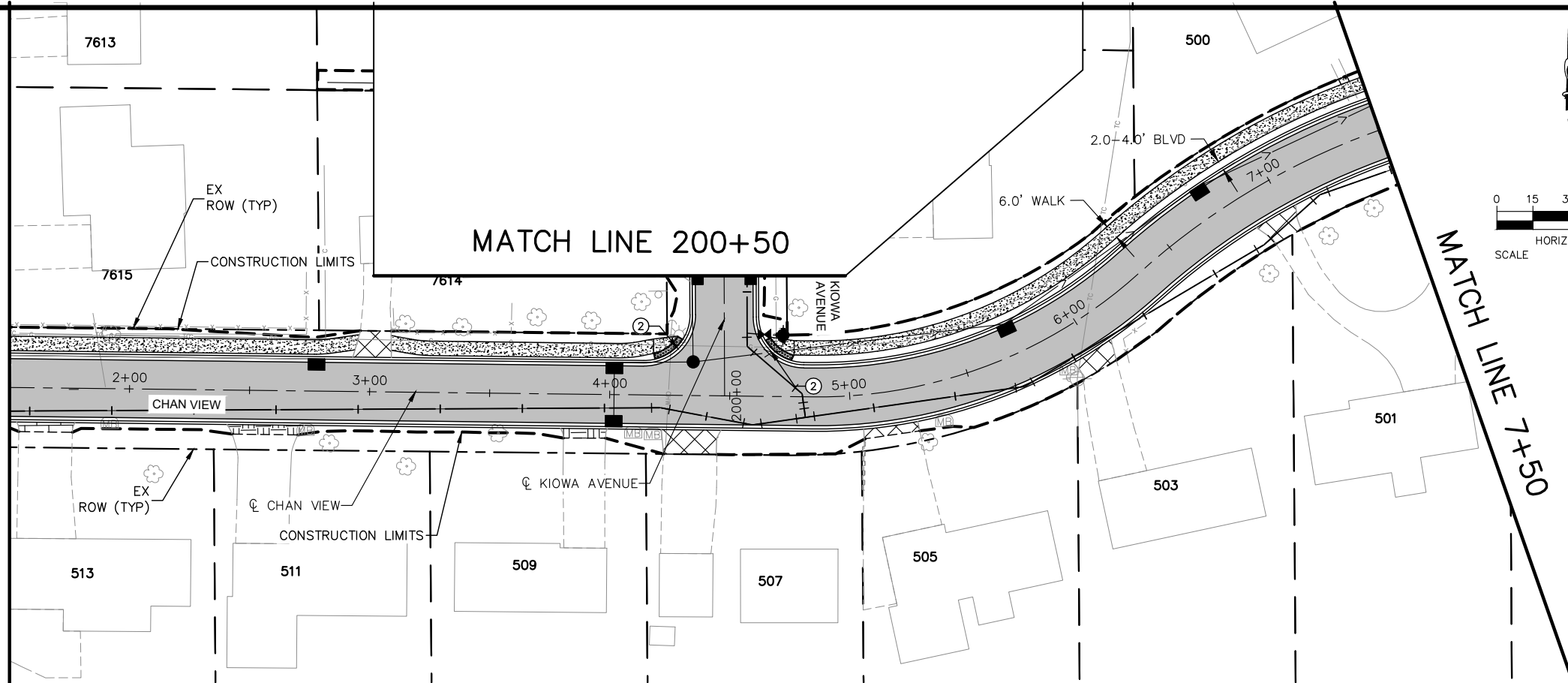

- LEGEND:**
- 2" BITUMINOUS MILL & OVERLAY (SEE INSET C)
 - FULL DEPTH RECLAMATION (SEE INSET B)
 - FULL DEPTH RECONSTRUCTION (SEE INSET A)
 - CONCRETE SIDEWALK (SEE INSET E)
 - 3" BITUMINOUS WALK (SEE INSET H)
 - TRUNCATED DOMES
 - CONCRETE DRIVEWAY REPLACEMENT (SEE INSET G)
 - BITUMINOUS DRIVEWAY REPLACEMENT (SEE INSET F)
 - PAVER DRIVEWAY REPLACEMENT
 - FULL DEPTH SAW CUT
 - CONSTRUCTION LIMITS
 - PROPOSED CURB & GUTTER
 - EXISTING RIGHT-OF-WAY
 - BID ALT MATCH LINE (SEE STATEMENT OF ESTIMATED QUANTITIES FOR DETAILS)

- GENERAL NOTES:**
1. ALL CURB IS SURMOUNTABLE CURB AND GUTTER, UNLESS OTHERWISE NOTED.
 2. ALL DIMENSIONS ARE FACE OF CURB UNLESS OTHERWISE NOTED.
 3. ENGINEER TO IDENTIFY AND MARK LOCATIONS FOR CONCRETE WALK REPLACEMENT.
 4. ENGINEER TO IDENTIFY AND MARK LOCATIONS FOR CONCRETE AND BITUMINOUS DRIVEWAY REPLACEMENTS.

- NOTES:**
- ① B618 CURB AND GUTTER
 - ② SEE CITY STANDARD PLATE 5204 FOR TYPICAL CURB RADIUS DETAILS.
 - ③ PEDESTRIAN CURB RAMP (SEE INTERSECTION DETAILS)
 - ④ CURB CUT, SEE DETAIL ON SHEET 111. SEE GRADING PLAN, SHEET 112 FOR DETAILS.

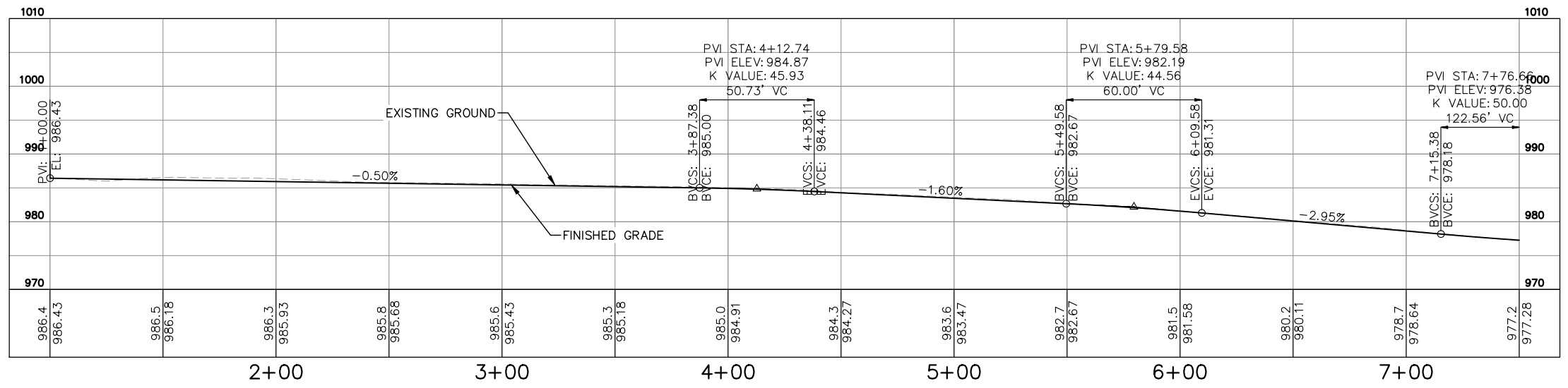
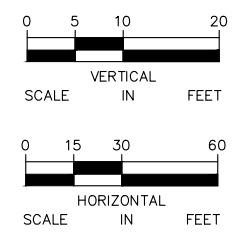

No.	Date	Revisions	App.

DRAWING NAME	2024_PaveRehab_P&P.dwg
DESIGNED BY:	MAK
DRAWN BY:	RCH
CHECKED BY:	MAK
DATE:	02/29/2024
PROJECT NO.	24-01

Kimley»Horn

11995 SINGLETREE LANE, SUITE 225, EDEN PRAIRIE, MN 55344
 PHONE: 612-315-1272
 WWW.KIMLEY-HORN.COM

I HEREBY CERTIFY THAT THIS PLAN, SPECIFICATION OR REPORT WAS PREPARED BY ME OR UNDER MY DIRECT SUPERVISION AND THAT I AM A DULY LICENSED PROFESSIONAL ENGINEER UNDER THE LAWS OF THE STATE OF MINNESOTA.

Michael A. Kirsch
 MICHAEL A. KIRSCH
 DATE: 02/29/2024 MN LIC. NO. 59057



CITY OF CHANHASSEN
 2024 CITY PAVEMENT
 REHABILITATION PROJECT

CONSTRUCTION PLAN & PROFILE
 CHAN VIEW
 STA. 1+50 TO STA. 7+50

CITY PROJECT	24-01	SHEET NO.	126
		188	

- LEGEND:**
- 2" BITUMINOUS MILL & OVERLAY (SEE INSET C)
 - FULL DEPTH RECLAMATION (SEE INSET B)
 - FULL DEPTH RECONSTRUCTION (SEE INSET A)
 - CONCRETE SIDEWALK (SEE INSET E)
 - 3" BITUMINOUS WALK (SEE INSET H)
 - TRUNCATED DOMES
 - CONCRETE DRIVEWAY REPLACEMENT (SEE INSET G)
 - BITUMINOUS DRIVEWAY REPLACEMENT (SEE INSET F)
 - PAVER DRIVEWAY REPLACEMENT
 - FULL DEPTH SAW CUT
 - CONSTRUCTION LIMITS
 - PROPOSED CURB & GUTTER
 - EXISTING RIGHT-OF-WAY
 - BID ALT MATCH LINE (SEE STATEMENT OF ESTIMATED QUANTITIES FOR DETAILS)

- GENERAL NOTES:**
1. ALL CURB IS SURMOUNTABLE CURB AND GUTTER, UNLESS OTHERWISE NOTED.
 2. ALL DIMENSIONS ARE FACE OF CURB UNLESS OTHERWISE NOTED.
 3. ENGINEER TO IDENTIFY AND MARK LOCATIONS FOR CONCRETE WALK REPLACEMENT.
 4. ENGINEER TO IDENTIFY AND MARK LOCATIONS FOR CONCRETE AND BITUMINOUS DRIVEWAY REPLACEMENTS.

- NOTES:**
- ① B618 CURB AND GUTTER
 - ② SEE CITY STANDARD PLATE 5204 FOR TYPICAL CURB RADIUS DETAILS.
 - ③ PEDESTRIAN CURB RAMP (SEE INTERSECTION DETAILS)
 - ④ CURB CUT, SEE DETAIL ON SHEET 111. SEE GRADING PLAN, SHEET 112 FOR DETAILS.

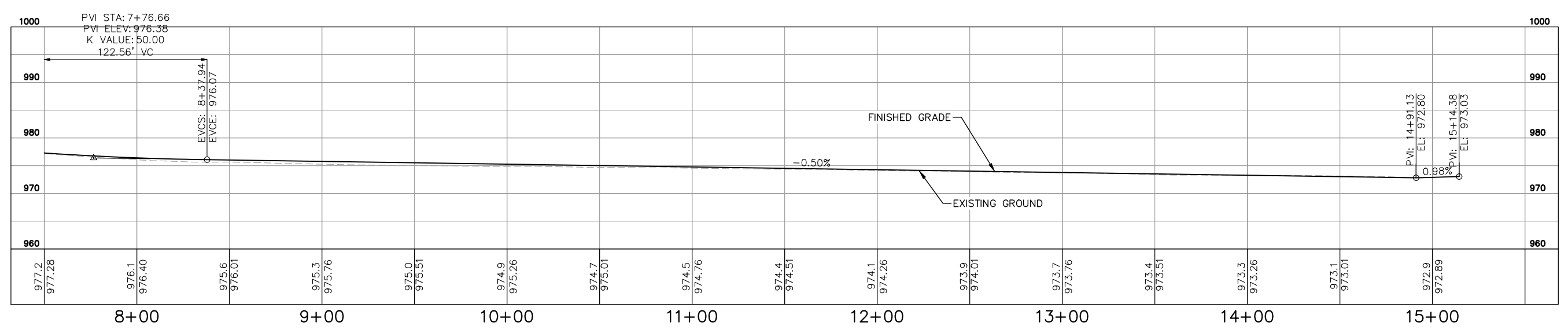
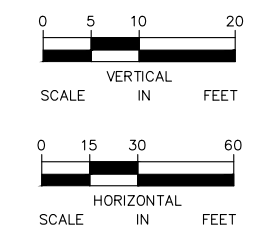
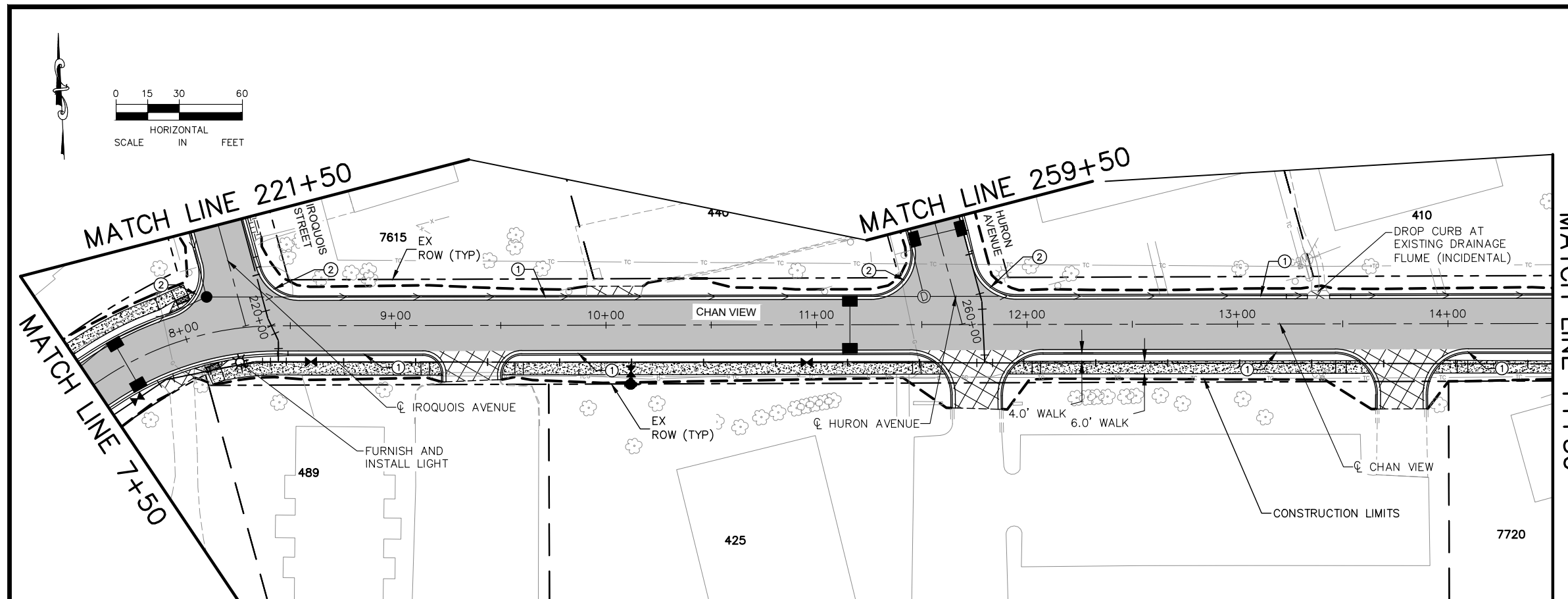

C:\Users\REED\OneDrive\AppData\Local\Temp\AcPublish\28308\2024_PaveRehab_P&P.dwg March 05, 2024 - 2:30pm

No.	Date	Revisions	App.	DRAWING NAME
				2024_PaveRehab_P&P.dwg
				DESIGNED BY: MAK
				DRAWN BY: RCH
				CHECKED BY: MAK
				DATE: 02/29/2024
				PROJECT NO. 24-01

Kimley»Horn

11995 SINGLETREE LANE, SUITE 225, EDEN PRAIRIE, MN 55344
 PHONE: 612-315-1272
 WWW.KIMLEY-HORN.COM

I HEREBY CERTIFY THAT THIS PLAN, SPECIFICATION OR REPORT WAS PREPARED BY ME OR UNDER MY DIRECT SUPERVISION AND THAT I AM A DULY LICENSED PROFESSIONAL ENGINEER UNDER THE LAWS OF THE STATE OF MINNESOTA.

Michael A. Kirsch
 MICHAEL A. KIRSCH
 DATE: 02/29/2024 MN LIC. NO. 59057

CITY OF CHANHASSEN
 2024 CITY PAVEMENT
 REHABILITATION PROJECT

CONSTRUCTION PLAN & PROFILE
 CHAN VIEW
 STA. 7+50 TO STA. 14+50

CITY PROJECT	24-01	SHEET NO.	127
		188	

k:\TOW_Civil\CITY\CHANHASSEN\2024 CITY STREET REHAB-RECON\CAD\Plan Sheets\2024_PaveRehab_P&P.dwg February 29, 2024 - 6:45pm

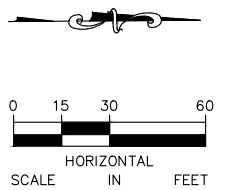
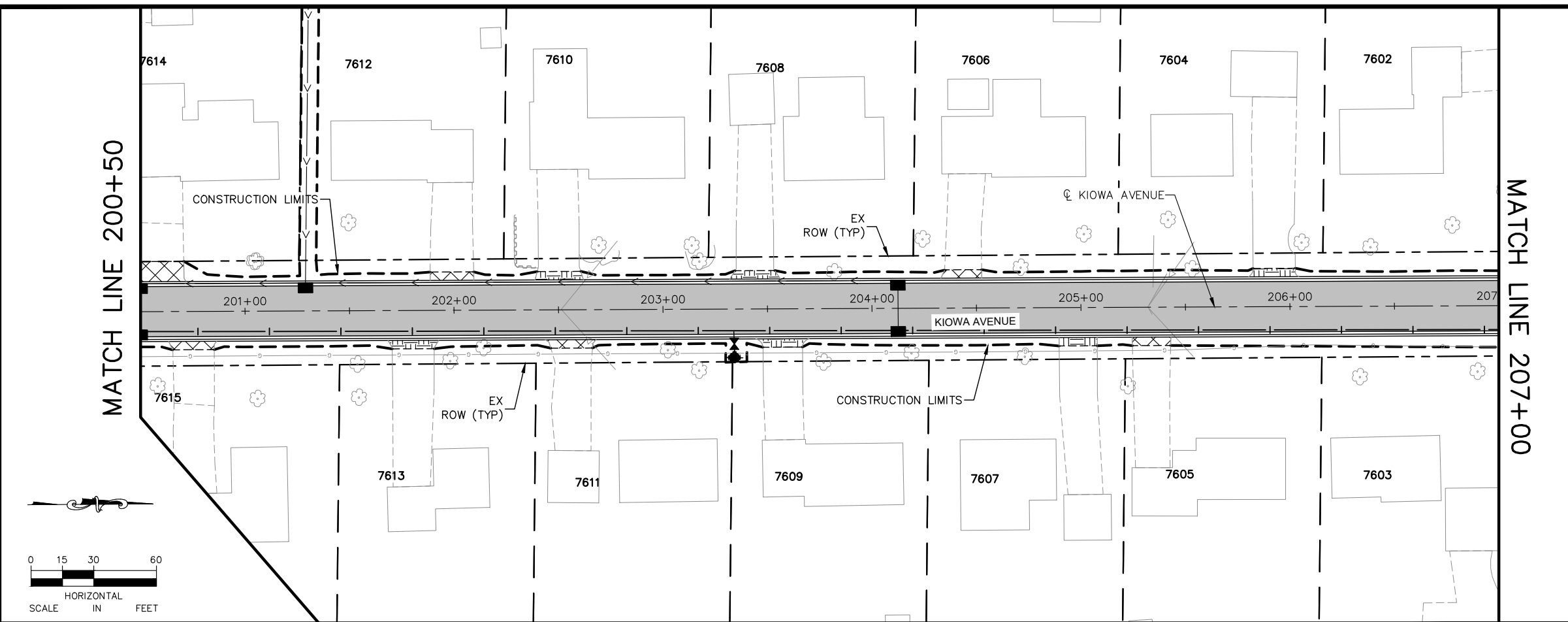

LEGEND:

- 2" BITUMINOUS MILL & OVERLAY (SEE INSET C)
- FULL DEPTH RECLAMATION (SEE INSET B)
- FULL DEPTH RECONSTRUCTION (SEE INSET A)
- CONCRETE SIDEWALK (SEE INSET E)
- 3" BITUMINOUS WALK (SEE INSET H)
- TRUNCATED DOMES
- CONCRETE DRIVEWAY REPLACEMENT (SEE INSET G)
- BITUMINOUS DRIVEWAY REPLACEMENT (SEE INSET F)
- PAVER DRIVEWAY REPLACEMENT
- FULL DEPTH SAW CUT
- CONSTRUCTION LIMITS
- PROPOSED CURB & GUTTER
- EXISTING RIGHT-OF-WAY
- BID ALT MATCH LINE (SEE STATEMENT OF ESTIMATED QUANTITIES FOR DETAILS)

- GENERAL NOTES:**
1. ALL CURB IS SURMOUNTABLE CURB AND GUTTER, UNLESS OTHERWISE NOTED.
 2. ALL DIMENSIONS ARE FACE OF CURB UNLESS OTHERWISE NOTED.
 3. ENGINEER TO IDENTIFY AND MARK LOCATIONS FOR CONCRETE WALK REPLACEMENT.
 4. ENGINEER TO IDENTIFY AND MARK LOCATIONS FOR CONCRETE AND BITUMINOUS DRIVEWAY REPLACEMENTS.

- NOTES:**
- ① B618 CURB AND GUTTER
 - ② SEE CITY STANDARD PLATE 5204 FOR TYPICAL CURB RADIUS DETAILS.
 - ③ PEDESTRIAN CURB RAMP (SEE INTERSECTION DETAILS)
 - ④ CURB CUT, SEE DETAIL ON SHEET 111. SEE GRADING PLAN, SHEET 112 FOR DETAILS.

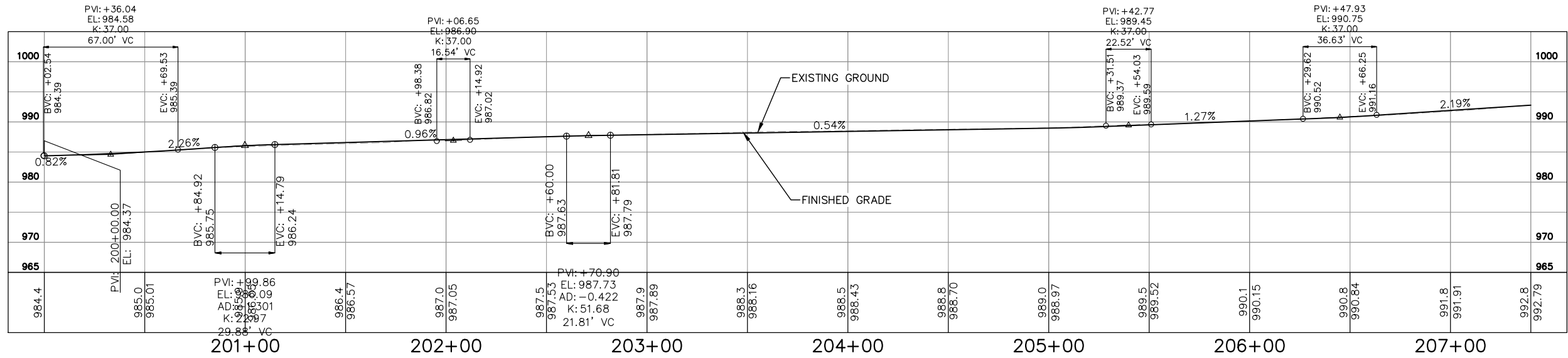
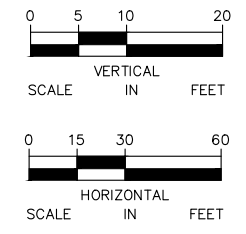

No.	Date	Revisions	App.

DRAWING NAME	2024_PaveRehab_P&P.dwg
DESIGNED BY:	MAK
DRAWN BY:	RCH
CHECKED BY:	MAK
DATE:	02/29/2024
PROJECT NO.	24-01

Kimley»Horn

11995 SINGLETREE LANE, SUITE 225, EDEN PRAIRIE, MN 55344
 PHONE: 612-315-1272
 WWW.KIMLEY-HORN.COM

I HEREBY CERTIFY THAT THIS PLAN, SPECIFICATION OR REPORT WAS PREPARED BY ME OR UNDER MY DIRECT SUPERVISION AND THAT I AM A DULY LICENSED PROFESSIONAL ENGINEER UNDER THE LAWS OF THE STATE OF MINNESOTA.

Michael A. Kirsch
 MICHAEL A. KIRSCH
 DATE: 02/29/2024 MN LIC. NO. 59057

CITY OF CHANHASSEN
 2024 CITY PAVEMENT
 REHABILITATION PROJECT

CONSTRUCTION PLAN & PROFILE
 KIOWA AVENUE
 STA. 200+50 TO STA. 207+00

CITY PROJECT	24-01	SHEET NO.	128
		188	

k:\TOW_Civil\CITY\CHANHASSEN\2024 CITY STREET REHAB-RECON\2024_PaveRehab_P&P.dwg February 29, 2024 - 6:45pm

MATCH LINE 220+50

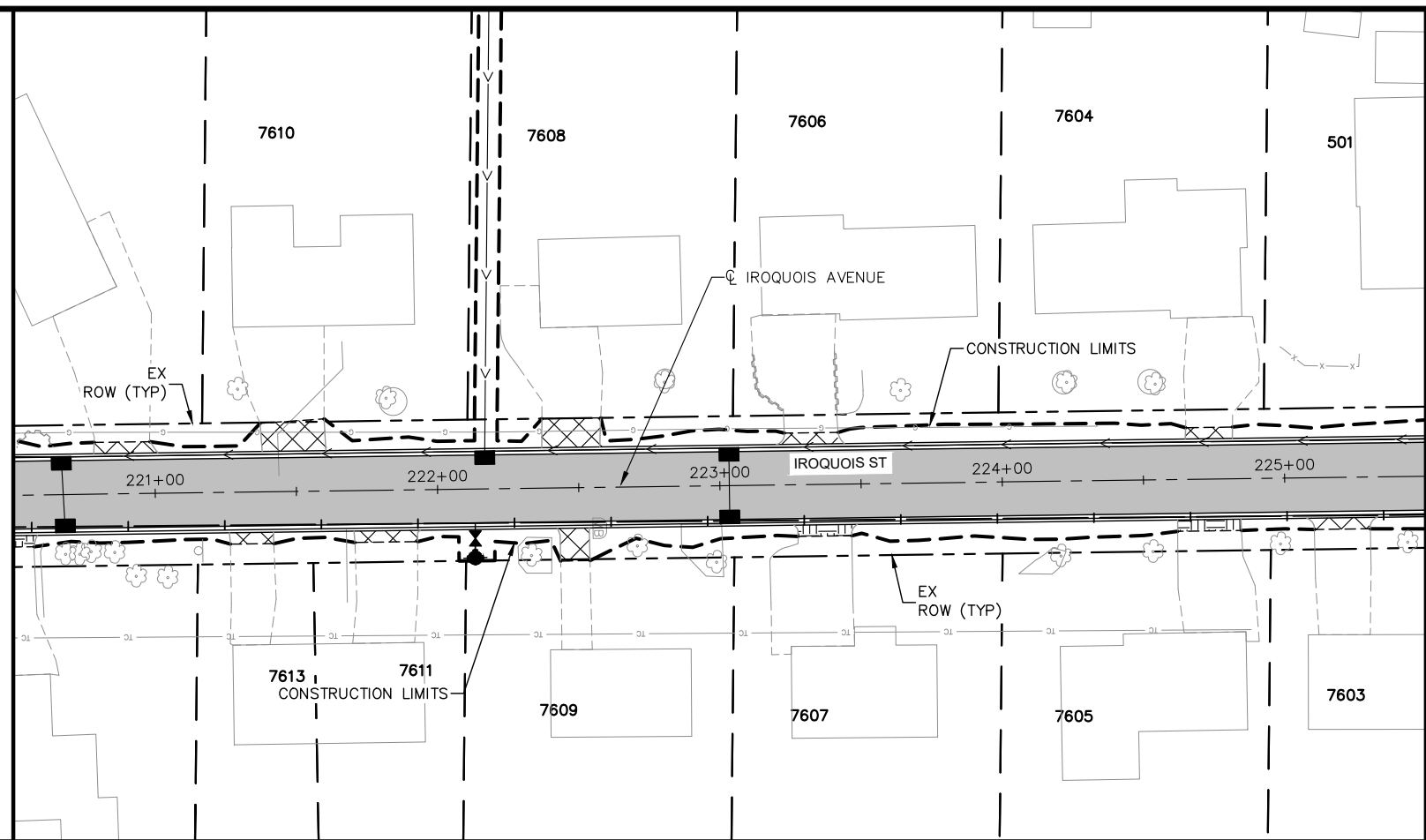

MATCH LINE 225+50

- LEGEND:**
- 2" BITUMINOUS MILL & OVERLAY (SEE INSET C)
 - FULL DEPTH RECLAMATION (SEE INSET B)
 - FULL DEPTH RECONSTRUCTION (SEE INSET A)
 - CONCRETE SIDEWALK (SEE INSET E)
 - 3" BITUMINOUS WALK (SEE INSET H)
 - TRUNCATED DOMES
 - CONCRETE DRIVEWAY REPLACEMENT (SEE INSET G)
 - BITUMINOUS DRIVEWAY REPLACEMENT (SEE INSET F)
 - PAVER DRIVEWAY REPLACEMENT
 - FULL DEPTH SAW CUT
 - CONSTRUCTION LIMITS
 - PROPOSED CURB & GUTTER
 - EXISTING RIGHT-OF-WAY
 - BID ALT MATCH LINE (SEE STATEMENT OF ESTIMATED QUANTITIES FOR DETAILS)

- GENERAL NOTES:**
1. ALL CURB IS SURMOUNTABLE CURB AND GUTTER, UNLESS OTHERWISE NOTED.
 2. ALL DIMENSIONS ARE FACE OF CURB UNLESS OTHERWISE NOTED
 3. ENGINEER TO IDENTIFY AND MARK LOCATIONS FOR CONCRETE WALK REPLACEMENT
 4. ENGINEER TO IDENTIFY AND MARK LOCATIONS FOR CONCRETE AND BITUMINOUS DRIVEWAY REPLACEMENTS.

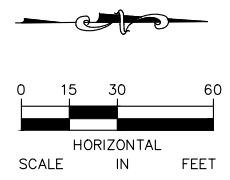

- NOTES:**
- ① B618 CURB AND GUTTER
 - ② SEE CITY STANDARD PLATE 5204 FOR TYPICAL CURB RADIUS DETAILS.
 - ③ PEDESTRIAN CURB RAMP (SEE INTERSECTION DETAILS)
 - ④ CURB CUT, SEE DETAIL ON SHEET 111. SEE GRADING PLAN, SHEET 112 FOR DETAILS.

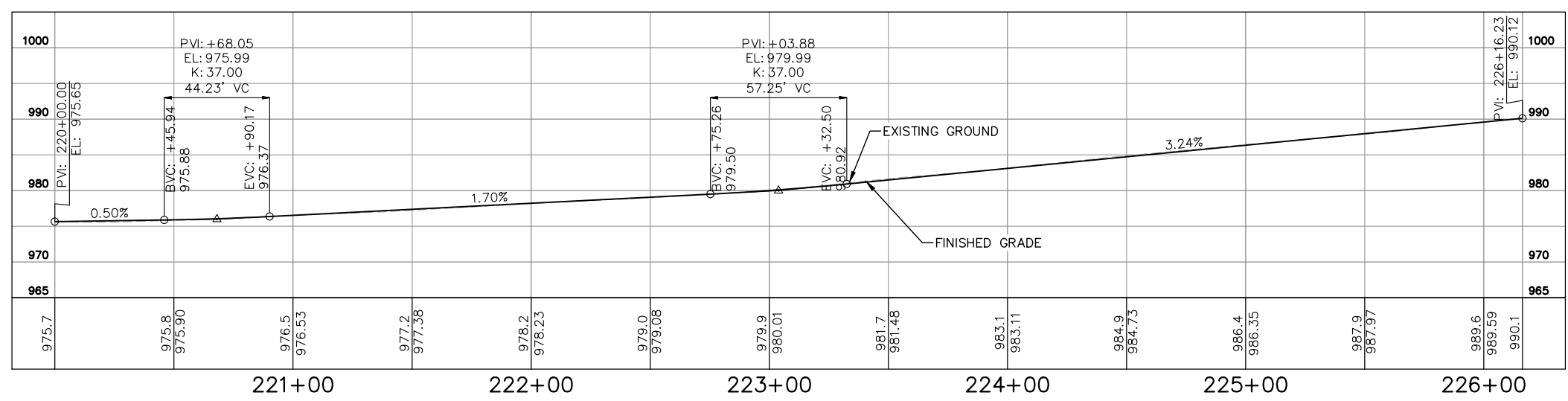
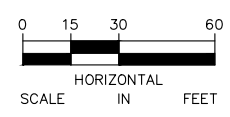
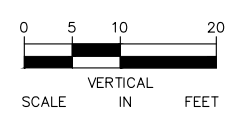

No.	Date	Revisions	App.

DRAWING NAME	2024_PaveRehab_P&P.dwg
DESIGNED BY:	MAK
DRAWN BY:	RCH
CHECKED BY:	MAK
DATE:	02/29/2024
PROJECT NO.	24-01

Kimley»Horn

11995 SINGLETREE LANE, SUITE 225, EDEN PRAIRIE, MN 55344
 PHONE: 612-315-1272
 WWW.KIMLEY-HORN.COM

I HEREBY CERTIFY THAT THIS PLAN, SPECIFICATION OR REPORT WAS PREPARED BY ME OR UNDER MY DIRECT SUPERVISION AND THAT I AM A DULY LICENSED PROFESSIONAL ENGINEER UNDER THE LAWS OF THE STATE OF MINNESOTA.

Michael A. Kirsch
 MICHAEL A. KIRSCH
 DATE: 02/29/2024 MN LIC. NO. 59057



CITY OF CHANHASSEN
 2024 CITY PAVEMENT
 REHABILITATION PROJECT

CONSTRUCTION PLAN & PROFILE
 IROQUOIS STREET
 STA. 220+50 TO STA. 225+50

CITY PROJECT	24-01	SHEET NO.	129
		188	

k:\TOW_Civil\CITY\CHANHASSEN\2024 CITY STREET REHAB-RECON\CAD\Plan Sheets\2024_PaveRehab_P&P.dwg February 29, 2024 - 6:46pm

MATCH LINE 260+50

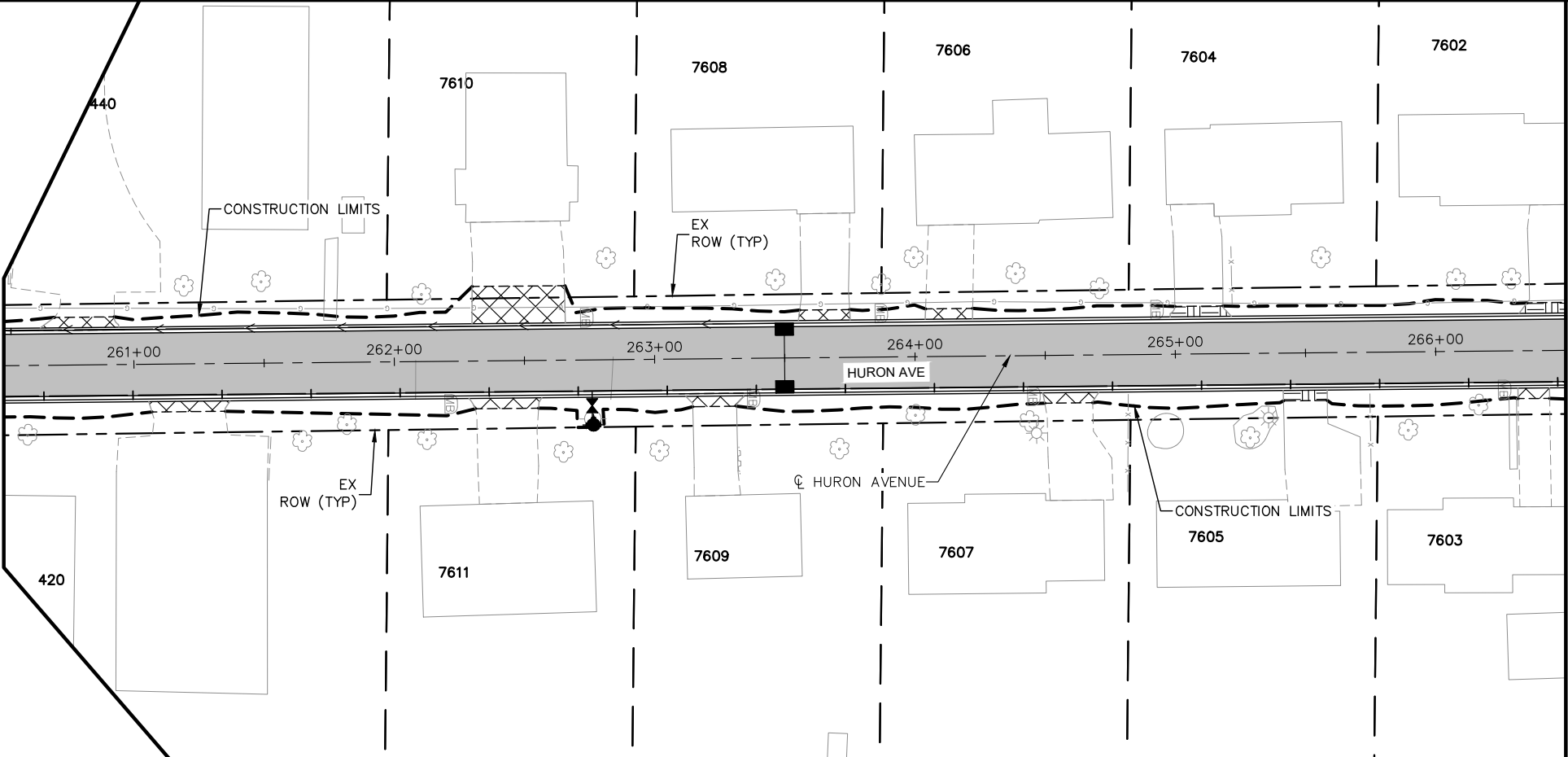

MATCH LINE 266+50

- LEGEND:**
- 2" BITUMINOUS MILL & OVERLAY (SEE INSET C)
 - FULL DEPTH RECLAMATION (SEE INSET B)
 - FULL DEPTH RECONSTRUCTION (SEE INSET A)
 - CONCRETE SIDEWALK (SEE INSET E)
 - 3" BITUMINOUS WALK (SEE INSET H)
 - TRUNCATED DOMES
 - CONCRETE DRIVEWAY REPLACEMENT (SEE INSET G)
 - BITUMINOUS DRIVEWAY REPLACEMENT (SEE INSET F)
 - PAVER DRIVEWAY REPLACEMENT
 - FULL DEPTH SAW CUT
 - CONSTRUCTION LIMITS
 - PROPOSED CURB & GUTTER
 - EXISTING RIGHT-OF-WAY
 - BID ALT MATCH LINE (SEE STATEMENT OF ESTIMATED QUANTITIES FOR DETAILS)

- GENERAL NOTES:**
1. ALL CURB IS SURMOUNTABLE CURB AND GUTTER, UNLESS OTHERWISE NOTED.
 2. ALL DIMENSIONS ARE FACE OF CURB UNLESS OTHERWISE NOTED
 3. ENGINEER TO IDENTIFY AND MARK LOCATIONS FOR CONCRETE WALK REPLACEMENT
 4. ENGINEER TO IDENTIFY AND MARK LOCATIONS FOR CONCRETE AND BITUMINOUS DRIVEWAY REPLACEMENTS.

- NOTES:**
- ① B618 CURB AND GUTTER
 - ② SEE CITY STANDARD PLATE 5204 FOR TYPICAL CURB RADIUS DETAILS.
 - ③ PEDESTRIAN CURB RAMP (SEE INTERSECTION DETAILS)
 - ④ CURB CUT, SEE DETAIL ON SHEET 111. SEE GRADING PLAN, SHEET 112 FOR DETAILS.

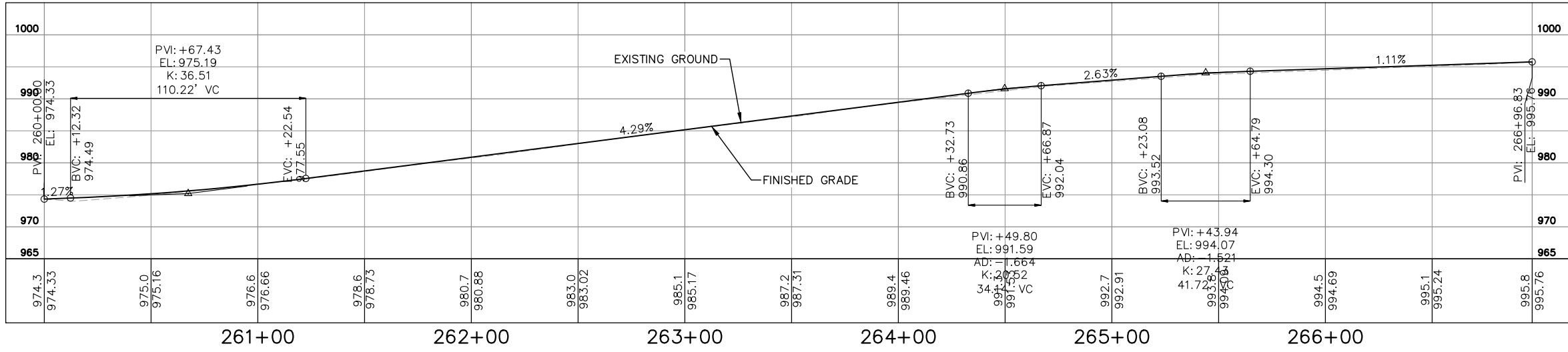
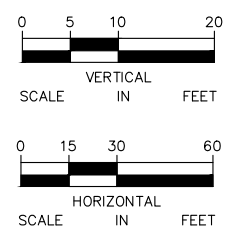

No.	Date	Revisions	App.

DRAWING NAME 2024_PaveRehab_P&P.dwg	
DESIGNED BY:	MAK
DRAWN BY:	RCH
CHECKED BY:	MAK
DATE:	02/29/2024
PROJECT NO.	24-01

Kimley»Horn

11995 SINGLETREE LANE, SUITE 225, EDEN PRAIRIE, MN 55344
 PHONE: 612-315-1272
 WWW.KIMLEY-HORN.COM

I HEREBY CERTIFY THAT THIS PLAN, SPECIFICATION OR REPORT WAS PREPARED BY ME OR UNDER MY DIRECT SUPERVISION AND THAT I AM A DULY LICENSED PROFESSIONAL ENGINEER UNDER THE LAWS OF THE STATE OF MINNESOTA.

Michael A. Kirsch
 MICHAEL A. KIRSCH
 DATE: 02/29/2024 MN LIC. NO. 59057



CITY OF CHANHASSEN
 2024 CITY PAVEMENT
 REHABILITATION PROJECT

CONSTRUCTION PLAN & PROFILE
 HURON AVENUE
 STA. 260+50 TO STA. 266+50

CITY PROJECT	24-01	SHEET NO.	130
		188	

k:\TOW_Civil\CITY\CHANHASSEN\2024 CITY STREET REHAB-RECON\CAD\Plan Sheets\2024_PaveRehab_P&P.dwg February 29, 2024 - 6:46pm

MATCH LINE 280+50

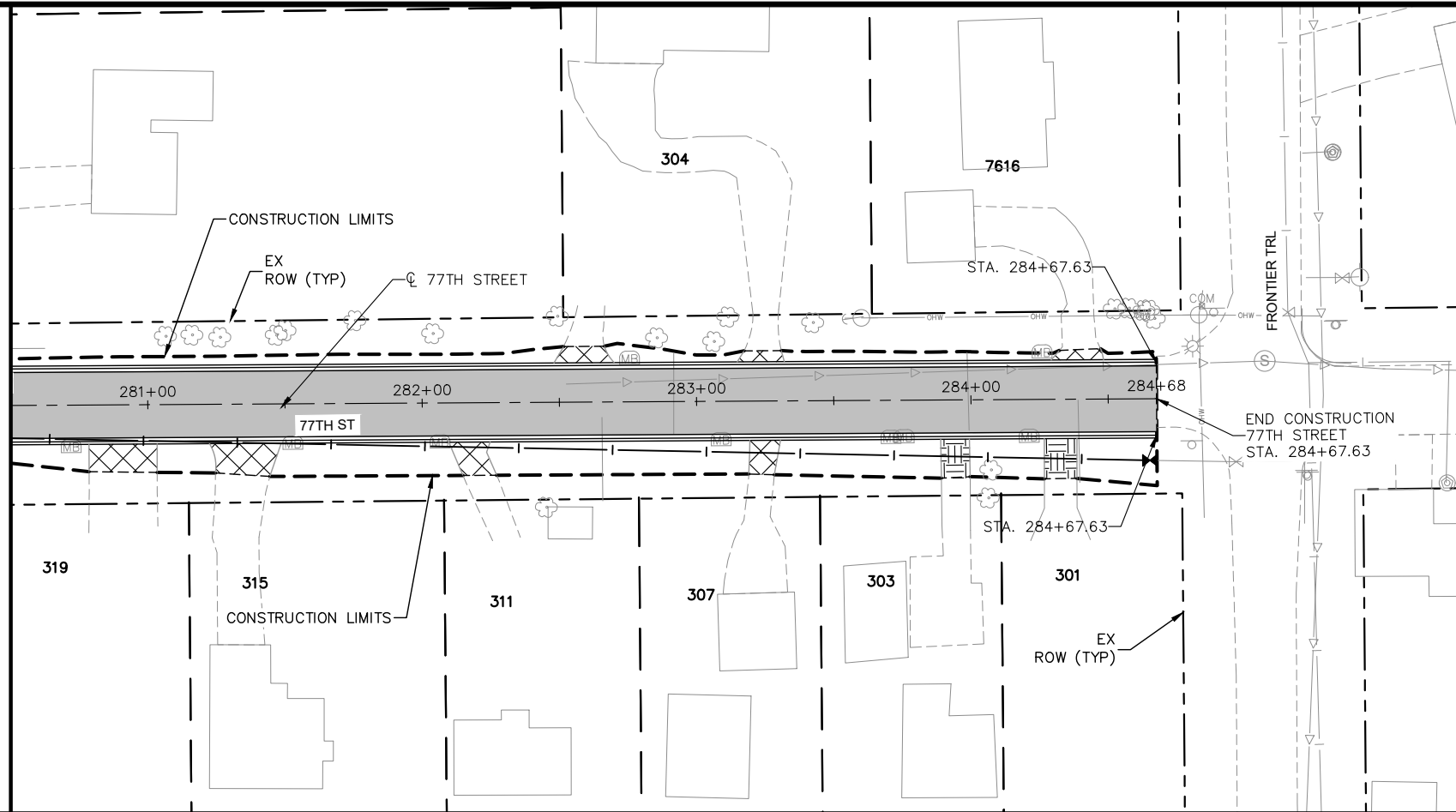

LEGEND:

- 2" BITUMINOUS MILL & OVERLAY (SEE INSET C)
- FULL DEPTH RECLAMATION (SEE INSET B)
- FULL DEPTH RECONSTRUCTION (SEE INSET A)
- CONCRETE SIDEWALK (SEE INSET E)
- 3" BITUMINOUS WALK (SEE INSET H)
- TRUNCATED DOMES
- CONCRETE DRIVEWAY REPLACEMENT (SEE INSET G)
- BITUMINOUS DRIVEWAY REPLACEMENT (SEE INSET F)
- PAVER DRIVEWAY REPLACEMENT
- FULL DEPTH SAW CUT
- CONSTRUCTION LIMITS
- PROPOSED CURB & GUTTER
- EXISTING RIGHT-OF-WAY
- BID ALT MATCH LINE (SEE STATEMENT OF ESTIMATED QUANTITIES FOR DETAILS)

GENERAL NOTES:

1. ALL CURB IS SURMOUNTABLE CURB AND GUTTER, UNLESS OTHERWISE NOTED.
2. ALL DIMENSIONS ARE FACE OF CURB UNLESS OTHERWISE NOTED.
3. ENGINEER TO IDENTIFY AND MARK LOCATIONS FOR CONCRETE WALK REPLACEMENT.
4. ENGINEER TO IDENTIFY AND MARK LOCATIONS FOR CONCRETE AND BITUMINOUS DRIVEWAY REPLACEMENTS.

NOTES:

- ① B618 CURB AND GUTTER
- ② SEE CITY STANDARD PLATE 5204 FOR TYPICAL CURB RADIUS DETAILS.
- ③ PEDESTRIAN CURB RAMP (SEE INTERSECTION DETAILS)
- ④ CURB CUT, SEE DETAIL ON SHEET 111. SEE GRADING PLAN, SHEET 112 FOR DETAILS.

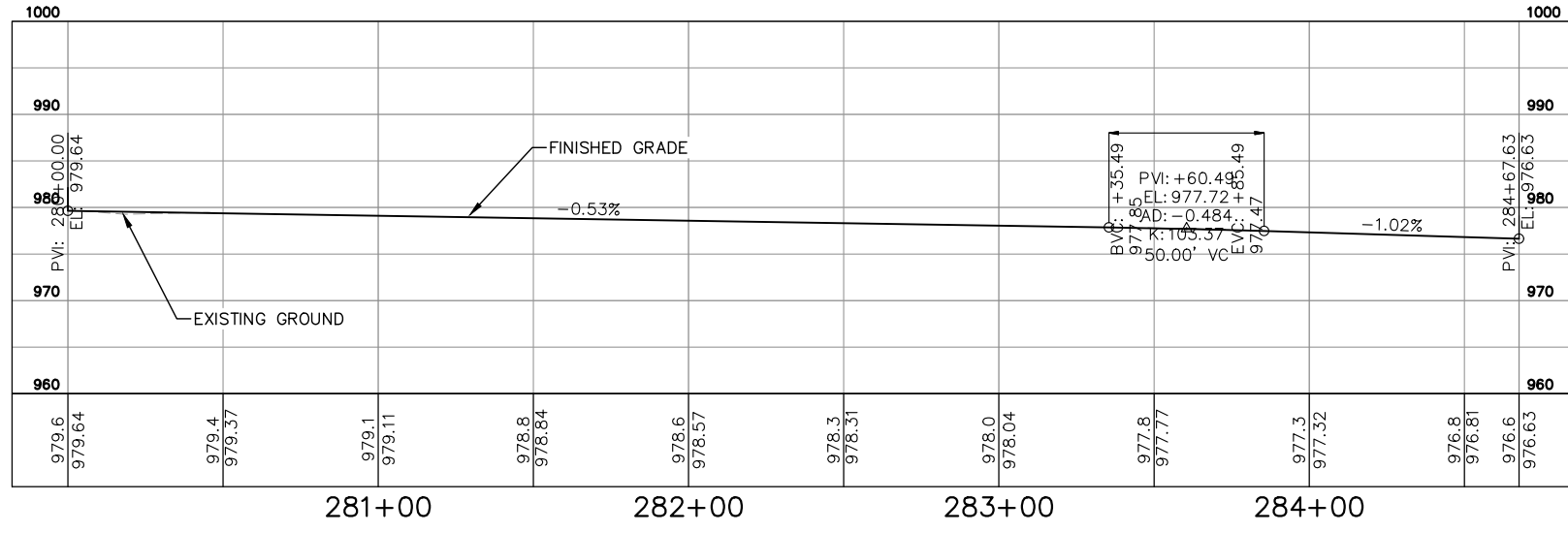
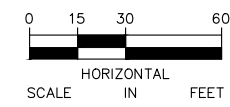
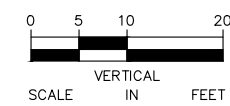
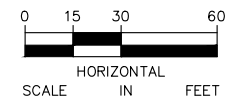

No.	Date	Revisions	App.

DRAWING NAME	2024_PaveRehab_P&P.dwg
DESIGNED BY:	MAK
DRAWN BY:	RCH
CHECKED BY:	MAK
DATE:	02/29/2024
PROJECT NO.	24-01

Kimley»Horn

11995 SINGLETREE LANE, SUITE 225, EDEN PRAIRIE, MN 55344
 PHONE: 612-315-1272
 WWW.KIMLEY-HORN.COM

I HEREBY CERTIFY THAT THIS PLAN, SPECIFICATION OR REPORT WAS PREPARED BY ME OR UNDER MY DIRECT SUPERVISION AND THAT I AM A DULY LICENSED PROFESSIONAL ENGINEER UNDER THE LAWS OF THE STATE OF MINNESOTA.

Michael A. Kirsch
 MICHAEL A. KIRSCH
 DATE: 02/29/2024 MN LIC. NO. 59057



CITY OF CHANHASSEN
 2024 CITY PAVEMENT
 REHABILITATION PROJECT

CONSTRUCTION PLAN & PROFILE
 77TH STREET
 STA. 280+50 TO STA. 284+68









CITY PROJECT 24-01

SHEET NO.
 131
 188

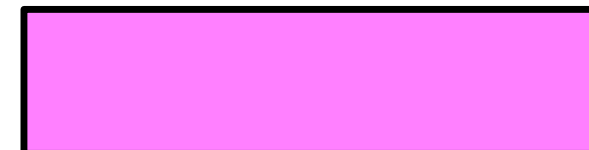
K:\TOW_Civil\City\CHANHASSEN\2024 CITY STREET REHAB-RECONST\CAD\Plan Sheets\Layouts\Chan 2024-Feasibility-Study-Layouts.dwg December 04, 2023 - 9:57am



LEGEND

-  1.5" MILL AND OVERLAY
-  2" MILL AND OVERLAY
-  FULL DEPTH RECLAMATION
-  FULL DEPTH RECONSTRUCTION
-  SURMOUNTABLE CONCRETE CURB & GUTTER
-  B612 CONCRETE CURB & GUTTER
-  SPOT CURB REPLACEMENT
-  3" BITUMINOUS TRAIL
-  6" CONCRETE SIDEWALK

CHANHASSEN CITY STREET REHABILITATION

FEASIBILITY LAYOUT

POTENTIAL RESIDENTIAL RAIN GARDEN LOCATION (LOTUS LAKE SUBWATERSHED)

APRIL 2024

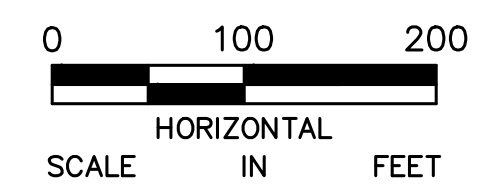
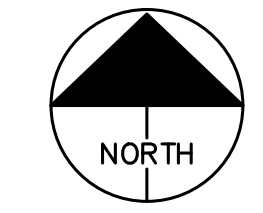



K:\TOW_Civil\City\CHANHASSEN\2024 CITY STREET REHAB-RECON\2024 City Street Exhibit\Feasibility\2024-RainGard_Example.dwg April 19, 2024 - 3:02pm



Kimley»Horn

11995 SINGLETREE LANE, SUITE 225
EDEN PRAIRIE, MINNESOTA 55344
Ph: 612-315-1272 www.kimley-horn.com

511 DEL RIO DRIVE
RAIN GARDEN EXAMPLE

2024 PAVEMENT REHABILITATION
CITY PROJECT NO. 24-01



Downtown Chanhassen Regional Stormwater Framework

Working Draft 6

City of Chanhassen, Minnesota
April 2024

Prepared by:

Kimley»Horn

TABLE OF CONTENTS

Table of Contents	i
List of Tables	ii
List of Figures	ii
1.0 Introduction.....	1
1.1 Project Overview.....	1
1.2 Project Background	2
2.0 Regulatory Considerations	2
2.1 City of Chanhassen	2
2.2 Riley Purgatory Bluff Creek Watershed District	3
2.3 Minnesota Pollution Control Agency.....	6
2.4 Other Considerations	7
3.0 Available Data.....	7
3.1 As-Built Storm Sewer Data.....	7
3.2 Project Area Plans	7
3.3 RPBCWD Models	9
3.4 Field Observations.....	9
3.5 Soils Information	10
4.0 Analysis and Results.....	11
4.1 Evaluation Tools	11
4.2 Regional Project Area Requirements	12
4.3 Abstraction and Treatment Options.....	13
4.4 Recommended Improvements	15
5.0 Implementation Plan	16
5.1 Watershed District Approval.....	16
5.2 Implementation Framework.....	17
6.0 Conclusion	20
Appendix A – Figures	
Appendix B – Soil Testing Summary	
Appendix C – Irrigation Data Summary	

LIST OF TABLES

Table 1. Study Area Project Requirements Summary	13
Table 2A. Credit Accounting Framework (1"/week Reuse)	18
Table 2B. Credit Accounting Framework (1.65"/week Reuse).....	19
Table 2C. Credit Accounting Framework (2"/week Reuse)	19

LIST OF FIGURES

Figure 1. Downtown Regional Project Area (Barr/RPBCWD)	1
Figure 2. Impaired Waters and Drinking Water Emergency Response Areas	7
Figure 3. Market Boulevard Improvements Preliminary Layout	8
Figure 4. Civic Campus Preliminary Plan (HKG).....	9
Figure 5. Irrigation Area Soil Test Locations	10

The following Figures are located in Appendix A in addition to full sized versions of Figures 3, 4 and 5

Figure 6. Reuse Irrigation Areas	
Figure 7. Projects and Opportunities in the Downtown Study Area	
Figure 8. Reuse Forcemain Alignment and Profile Concept	
Figure 9. Market Street Filtration Area Concept	
Figure 10. 79 th Street Filtration Area Concepts	

1.0 INTRODUCTION

1.1 Project Overview

The city of Chanhassen (city) is in Carver County within the Riley Purgatory Bluff Creek Watershed District (District). The city's "Downtown Area" is in the northern portion of the Rice Marsh Lake watershed and is bounded by Lake Drive to the south, Highway 101 to the east and Kerber Boulevard to the west. The study area is generally bounded by Highway 5 to the south, Kerber Boulevard to the west, Great Plains Boulevard to the east and Santa Vera Drive to the north as shown in Figure 1. The project area generally includes the portions of downtown Chanhassen that fall within the drainage boundaries contributing to Rice Marsh Lake including the City Civic Campus, Chanhassen Elementary school, Market Boulevard, residential areas north and many commercial developments. Within the project area, there are multiple planned public construction projects and anticipated private redevelopment projects including the following:

- Local Street Rehabilitation (City Project 24-01, 2024)
- Chanhassen Civic Campus Redevelopment (2024-2026)
- Market Boulevard Reconstruction (2025)
- Other Downtown Redevelopment (TBD)

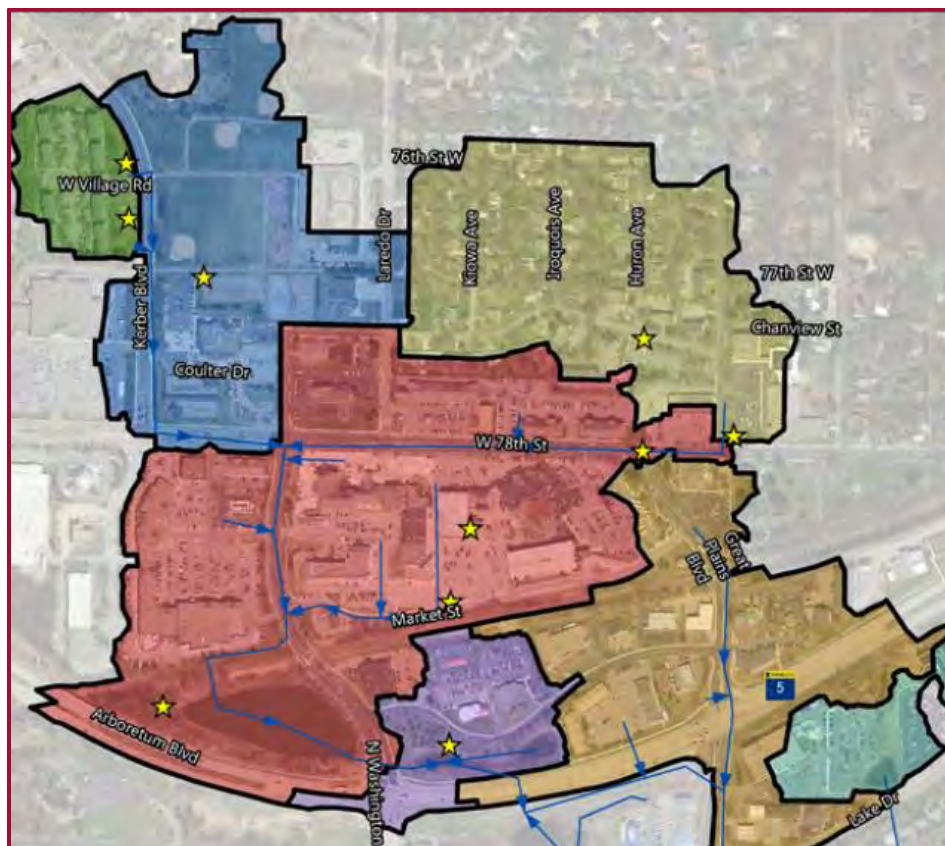

Figure 1. Downtown Regional Project Area (Barr/RPBCWD)

The purpose of this analysis and resulting framework is to evaluate the downtown area of Chanhassen for stormwater management opportunities and outline a regional stormwater best management practice (BMP) system that can be implemented in conjunction with the public projects in the area. Inherent in this regional framework is the reality that a regional approach for this area will result in greater overall water quality benefits than if each project were to be advanced individually through the permitting project. In addition, none of the individual projects would be able to incur the costs of the regional reuse system alone. Having multiple projects underway in this area in the same timeframe provides the City with an opportunity to take this regional approach in a cost-effective manner. The corresponding framework is intended to provide a realistic estimate of the regulatory credits that can be created by regional BMPs, and to establish a regulatory credit accounting approach that future projects within the downtown area can draw from.

1.2 Project Background

In April 2017, RPBCWD completed a study of the Rice Lake sub watershed, including the downtown area, was completed to develop a prioritized list of stormwater BMPs within the highly developed area (Downtown Chanhassen BMP Retrofit Assessment Findings Report, 2017). The study showed that opportunities for soluble phosphorus stormwater treatment systems within the downtown area are limited by extensive impervious surfaces and restrictive soils. However, the study identified a number of opportunities for regional scale practices, including the potential to construct a stormwater reuse facility using water from the existing regional stormwater pond (RM_5) at the northwest corner of Market Boulevard and Highway 5.

In 2023, the city began the initial work towards developing a final design for the Market Boulevard Reconstruction project. The Market Boulevard project is within the downtown regional area and provides a prime opportunity to leverage the reconstruction along the roadway to install the force main needed to connect the large stormwater pond along HWY 5 to the irrigation areas in the Civic Campus area. The force main is a critical piece of the infrastructure needed for a regional stormwater reuse/treatment BMP system to function. In addition to Market Boulevard, the city's Civic Campus redevelopment, and several other areas within the regional area are likely to redevelop next few years. This report summarizes the analysis for the potential regional stormwater BMPs, along with recommendations, and establishes a regulatory framework that will be used alongside the individual project permitting efforts to account for regulatory credits created and used for the multiple projects within the downtown area.

2.0 REGULATORY CONSIDERATIONS

Several regulatory agencies have jurisdiction over the drainage system, natural resources and potential improvements that have been considered through this initial evaluation. A summary of the key issues and regulatory criteria is provided in the following sections.

2.1 City of Chanhassen

The city currently requires new developments and projects to construct stormwater infrastructure that provide rate control and water quality treatment. The design standard for the stormwater quality treatment is to remove at least 60 percent of total phosphorus (TP) and 90 percent of the total suspended solids (TSS) generated by new and reconstructed impervious area. The city requires water quality modeling or computations to be submitted with the applicable permit to support the stated removal efficiency. The city

maintains a stormwater pollution prevention program (SWPPP) as required for an owner of a municipally separate storm sewer system (MS4).

2.2 Riley Purgatory Bluff Creek Watershed District

The RPBCWD or District administers a set of rules covering topics ranging from floodplain management, to dredging and sediment removal to stormwater management and several others. For the purposes of this summary report and the regional framework, Rule J - Stormwater Management, is the focal point.

Individual projects using a portion of the regulatory stormwater credits under this regional framework will still need to demonstrate compliance with other rule sections applicable to the specific project. The District's current stormwater management rule applies to land disturbing activity involving alteration or removal of 5,000 square feet land or vegetation and has specific requirements for redevelopment projects and linear projects. Both categories of project standards are summarized in the following sections.

RULE J - REDEVELOPMENT PROJECT CRITERIA

The District's current stormwater rule for development sites applies where a project disturbs 50 percent of the existing impervious area of the parcel or will increase the impervious by more than 50 percent. The City's Civic Campus improvements and all of the private project sites included in the study area fall within this category. Requirements for rate, abstraction and water quality are:

- **Rate Control:** Limit site discharge to existing conditions for the 2-, 10-, and 100-year Atlas 14 24-hour rainfall events as well as the 100-year, 10-day snowmelt event. For the purposes of the regional analysis, the most relevant location to assess rate control is at the crossing of TH 5 as shown in Figure 1.
- **Volume (Abstraction):** 1.1 inches of runoff from regulated impervious surfaces. An alternative management scheme for volume control for sites where infiltration of runoff is either not feasible or restricted by site specific conditions which are designated as "restricted sites". The volume control standard is 0.55 inches of runoff from impervious surfaces to be treated on site or the maximum extent practicable to be treated on site, or off-site management.
- **Water Quality:** Meet volume criteria or provide 90 percent TSS removal and an annual TP removal of 60 percent and result in no increase in TSS or TP loading as compared to existing conditions.

RULE J - LINEAR PROJECT CRITERIA

A linear project creating 10,000 square feet or more of new impervious or 25,000 square feet of fully reconstructed impervious surface must meet the stormwater criteria below. The City's Market Boulevard and Local Street reconstruction improvements fall within this category. Requirements for rate, abstraction and water quality are:

- **Rate Control:** Limit site discharge to existing conditions for the 2-, 10-, and 100-year Atlas 14 24-hour rainfall events as well as the 100-year, 10-day snowmelt event. For the purposes of the regional analysis, the most relevant location to assess rate control is at the crossing of TH 5 as shown in Figure 1.
- **Volume (Abstraction) and Water Quality:**
 - Projects creating between 10,000 square feet and 1 acre of new and or fully reconstructed impervious surface provide abstraction onsite of 1.1 inches of runoff from the net increase in impervious surface area; or

- Projects creating more than 1 acre of new and/or fully reconstructed impervious surface, meet the 90 percent TSS removal and an annual TP removal of 60 percent for all new and reconstructed impervious surface and provide abstraction of the larger of 0.55 inches of runoff from the new and fully reconstructed impervious surfaces, or 1.1 inches of runoff from the net increase in impervious area.

RULE J - RESTRICTED SITES

Where the district concurs that a project demonstrates that the volume abstraction standard as applicable cannot practicability be met through a combination of onsite BMPs and relocation of project elements to address varying soil conditions and other site constrictions or infiltration is reasonably likely to cause or exacerbate migration of underground contaminants, the applicant must provide rate and quality as described for site and linear projects and volume in the following priority sequence:

- Abstraction onsite of 0.55 inches of runoff from the regulated impervious surface
- Abstraction of runoff onsite to the maximum extent practicable
- Offsite abstraction and treatment in the same sub watershed as the proposed land disturbing activity according to site project criteria

RULE J - REGIONAL STORMWATER MANAGEMENT

A project may comply with the applicable project criteria in Section 3.1 of the District Rules for all parcels within a catchment area or areas through a regional or sub watershed plan approved by the district that plan must meet or exceed the applicable criteria of the project. The regional plan must provide for an annual accounting to the District of treatment capacity created and utilized by projects or land disturbing activities within the drainage and treatment areas within the plan area.

Our understanding of this rule section, which has not been used by a project in the District to date, is that it was intended to apply to a development or redevelopment area that is a collection of contiguous projects or parcels. That is, the regional project is bounded by a common border where all project areas are directly connected in terms of the stormwater management system with a linear roadway going through a mixed-use development area, for example. The reference to the standards of Section 3.1 supports this approach by applying a full 1.1 inches of volume abstraction to the entire project area.

For this Downtown Chanhassen Regional Framework approach, the project area is effectively the larger watershed draining to the regional wet pond, with very distinct and separate projects in parts of the larger drainage area. Some of these projects could otherwise be stand-alone linear and some could otherwise be stand-alone site redevelopment projects. Therefore, the city is requesting an exception under Rule K to this section of the rule to apply the 1.1-inch abstraction volume to the site redevelopment portions of the project while applying the 0.55-inch abstraction volume to the linear projects. All of these projects are in areas that have a number of constraints and restrictions to achieving abstraction volume due to right-of-way limitations and poor soils for infiltration. The outcome, will be a higher level of treatment and water quality benefit than if these separate projects were to be planned, designed, and permitted separately outside of a regional approach. See the Rule K section below for more details.

For the stormwater reuse-irrigation system proposed as the primary regional treatment feature for this area, the City will work with the District to monitor pumping records over time to assess the actual level of volume

treatment (credit) obtained and, if significantly different than the assumptions used as the basis for credits, make corresponding adjustments (increases or decreases) to the accounting of credits.

District approval of a regional plan requires a determination that use of a regional facility in place of onsite stormwater management is not reasonably likely to result in adverse impacts to local water resources, and that the plan incorporates onsite BMPs where necessary to mitigate impacts and provide local benefits not provided by the regional facility. The City understands that this will be the first time RPBCWD undertakes this regional plan approach provided in the District Rules and is committed to working closely with the District to develop and implement a successful plan.

RULE J – WETLAND PROTECTION

District rules Section 3.10 specifies that no activity may alter a site in a manner that alters the bounce in water level, duration of inundation, or change the runoff elevation for any wetland receiving discharge directly from the site beyond limits defined in the rule.

One wetland area that was discussed with District staff that could be subject to this rule provision is the basin in drainage area RM-A4.7, on the south side of TH 5. Discussions with the watershed indicate the basin may be considered a wetland mitigation area. A potential change in hydrology to the wetland area could result from the use of a portion of the runoff water that enters regional wet pond RM-P4.5 today, that will be used for irrigation purposes. Upon further review of the routing of the City and MnDOT drainage systems, the basin is not within the flow path of the upstream regional basin that will be used for irrigation. The wetland area flows north into the MnDOT TH 5 system before flowing south along Great Plain Boulevard. Therefore, no hydrology changes are anticipated for this area as a result of the planned improvements in the downtown area.

RULE K – EXCEPTIONS

Rule K specifies that the Board of Managers may approve an exception from a provision of the rules requiring a particular treatment or management strategy, or setting forth a design specification, if an applicant demonstrates that better natural resource protection or enhancement can be achieved by the project as proposed, than would strict compliance with the provision.

As stated in the Regional Stormwater Management section of Rule J, the city is requesting an exception under Rule K to this section of the rule to apply the 1.1-inch abstraction volume to the site redevelopment portions of the project while applying the 0.55-inch abstraction volume to the linear projects. The outcome, will be a higher level of treatment and water quality benefit than if these separate projects were to be planned, designed, and permitted separately outside of a regional approach. None of these individual projects alone would be able to bear the costs of implementing a regional treatment and reuse irrigation system to meet applicable rule requirements.

Without this regional approach, the linear projects would otherwise progress through the permitting process by following the sequencing steps for restricted sites (Rule J, Section 3.3). For City project 24-01 as an example, the design team has already completed the process to provide the maximum extent practicable (MEP) within the project limits according to Section 3.3.b. The volume created through this process is 576 CF of the required 7,305 CF for the project (See Tables 1 and 2) in the form of several rain gardens and larger biofiltration basins within the limited available right-of-way. The equivalent abstraction depth is 0.044 inches, less than 10% of the desired 0.55-inch level. While we have not completed a similar level of analysis on

Market Boulevard to date, we anticipate that may result in a comparable level of volume abstraction identified (not including the active filters planned as part of the regional approach). Regardless of the actual extent of volume abstraction that might be achieved within the Market Boulevard project limits, it would certainly be a small fraction of what will be achieved through the regional reuse system.

Therefore, this regional framework allows the city to achieve a higher level of MEP compared to pursuing individual projects on a stand-alone basis. This is true even if the abstraction volume obtained through the regional system is slightly less than the aggregate volume required for the linear and site projects as estimated later in this report. For example, the result may be that the Civic Campus site project gets to 1.1-inches using available credit and the Street 24-01 linear project gets to 0.55 inches using credits, but the Market Boulevard linear project only has 0.40 inches of remaining volume abstraction credit to draw from. The net result is a greater overall natural resource benefit than taking the individual project approach where each project may only be able to something on the order of half or less of the minimum regulatory requirement.

In addition to the regional system, each project is first evaluating and including project specific BMPs in the construction plans where feasible. The 24-01 Street project will install at least four (4) rain gardens plus additional residential rain gardens depending on the final responses from residents. The Market Boulevard project is exploring where, and what type of, additional BMPs could be installed.

2.3 Minnesota Pollution Control Agency

Projects identified within the study area will be required to obtain the MPCA Construction Stormwater General Permit if they disturb one or more acres of land. The permanent stormwater treatment requirements of the permit would apply if a given project results in 1 acre or more of net new impervious surfaces. The water quality volume required is one (1) inch times the net increase of impervious surfaces created by the project. The anticipated projects identified in this study are not likely to add 1 or more acres of impervious and therefore, not expected to trigger this permit requirement.

2.3.1 SPECIAL AND IMPAIRED WATERS

Lake Susan and Rice Marsh Lake are on the list for Minnesota Impaired Waters. Lake Susan is impaired for mercury and nutrients and TMDLs have been approved for these impairments. Rice Marsh Lake is also impaired for nutrients and has an approved TMDL. As shown in Figure 2, both of these waters are within 1 mile of the project area, while only Rice Marsh being in the downstream drainage area of the project area.

Much of the study area is within a Minnesota Department of Health (MDH) designated Emergency Response Area (ERA) designated by the cross-hatched area in Figure 2. The ERA represents an approved surface and subsurface area surrounding a public water supply well that completely contains the scientifically calculated 1 year time-of-travel and is managed by the entity identified in a wellhead protection plan (City of Chanhassen). There are no direct restrictions related to projects in the area since they are not also within a designated Drinking Water Supply Management Area.



Figure 2. Impaired Waters and Drinking Water Emergency Response Areas

2.4 Other Considerations

There are no FEMA mapped floodplains within the immediate project area. Downstream Marsh Lake is a mapped floodplain area. Nothing within the context of the projects proposed in this study area are anticipated to impact the FEMA mapped floodplain of Marsh Lake.

3.0 AVAILABLE DATA

Several sources of data were accessed to support completion of this preliminary drainage system analysis. Key data sources are discussed in the sections that follow.

3.1 As-Built Storm Sewer Data

The city of Chanhassen provided as-built plans on stormwater ponds, storm sewer, and other underground utility systems throughout the study area. Information on pipe sizes, lengths, material and inverts were gathered from the as-built plans for the purposes of studying potential BMP locations.

3.2 Project Area Plans

The project area includes several known and scheduled public projects as well as several potential private projects. Plans for each of the identified projects are at varying levels of completeness at the time of this study. Assumptions used in this study for each of the identified projects follows.

1. Market Boulevard Reconstruction. Plans are at a preliminary layout stage and nearing the 30% plan stage. The project layout as of March 2024 is shown in Figure 3. A full-sized figure of the Improvements and adjacent projects is provided in Appendix A. The Market Street project is the cornerstone of this regional approach in that it allows for a more cost-effective connection of the regional reuse water source and the irrigation areas to the north. The current base project plan is for reconstruction from TH 5 to W 78th Street. Construction is planned for 2025.

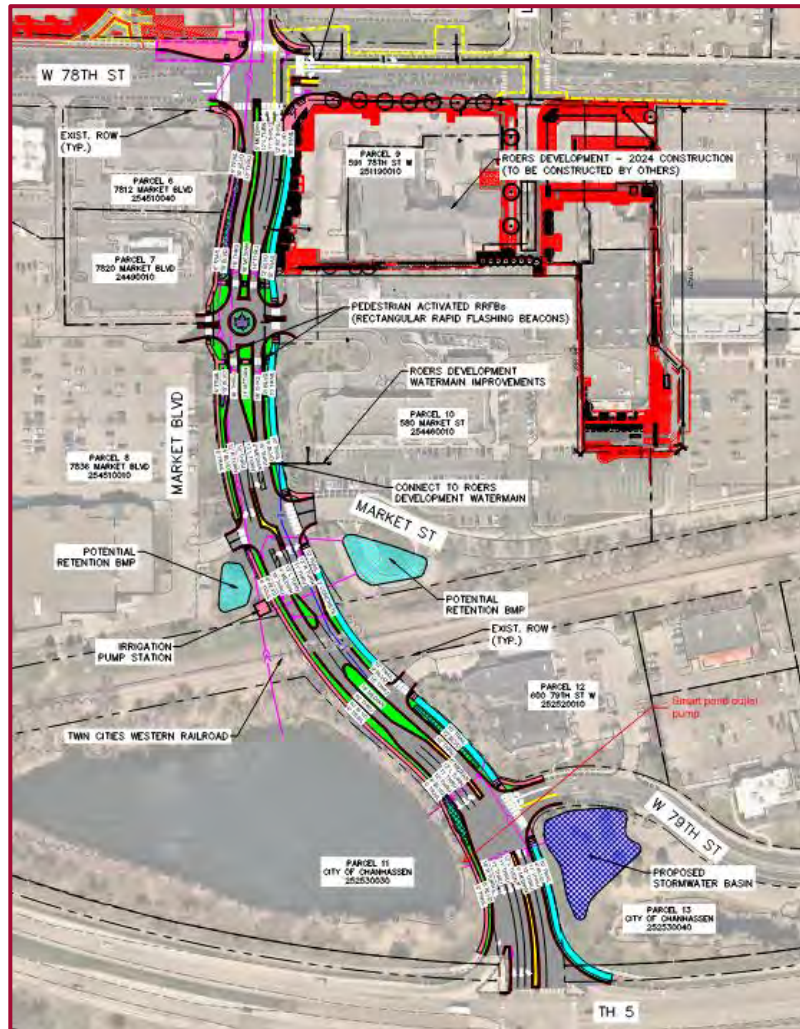

Figure 3. Market Boulevard Improvements Preliminary Layout

2. Chanhassen Civic Campus improvements. Plans are being bid with permit submittals to the City and Watershed district currently in process, shown in Figure 4. A full-sized figure of the planned campus improvements is provided in Appendix A. Impervious areas were taken from this layout assuming all areas will be reconstructed except for the existing Chanhassen Library, and structured parking. Construction is planned for 2024-2025.



Figure 4. Civic Campus Preliminary Plan (HKG1)

3. 24-01 Street Rehabilitation. Final plans completed in March 2024; impervious areas were taken from the final design plans. Construction is planned for 2024.
4. Private Redevelopment Projects. Construction could happen as soon as 2024 on one or more of these properties, although there are currently there is one development application being processed by the City and Watershed District for the Chanhassen Market Street Addition which involves the redevelopment of the Country Inn and Suites. The project design is managing its own stormwater without the use of the proposed regional BMP system. Each site was assumed to be fully impervious.

3.3 RPBCWD Models

Kimley-Horn received the district’s Rice Marsh regional PCSWMM model from the district (via Barr Engineering) encompassing the study area. Kimley-Horn used the model to inform the estimates of treatment capacity of the proposed regional BMPs and analyze the effects of the regional BMPs on the subwatershed.

Additionally, the district’s Rice Marsh P8 model was obtained and reviewed for confirming consistency of loading assumptions using in this analysis.

3.4 Field Observations

A site visit was completed as part of the study on June 19, 2023, to help understand the workings of the overall drainage system and to review potential regional stormwater treatment locations within the study area. Photos were taken to document significant storm sewer structures, areas identified for potential regional BMP and general site conditions.

3.5 Soils Information

Soil information used in this preliminary assessment was taken from the Web Soil Survey indicated soils generally having hydrologic group C and D characteristics throughout the study area. These data were used to estimate soil conditions in the reuse system irrigation area and to inform the assumption of limited infiltration potential in the remaining portions of the study area. The soils information discussed in the 2017 RPBCWD study indicated that soils in the downtown area were not likely to be conducive to infiltration.

Soils investigations for the Market Boulevard Improvements project and the Civic Campus improvements project will be completed as soon as the fall of 2023 and may extend to the spring of 2024. As these and other private development projects have boring results completed, there may be areas identified that are more conducive to infiltration. If and when these are identified, the City will reevaluate the potential for infiltration practices where possible.

Soils investigation for the 24-01 street project consisting of testing for infiltration rates, was completed in the fall of 2023. The results confirmed for most of the 24-01 project area that the soil capacity for infiltration was very limited, requiring the proposed rain gardens to all be constructed with a tile underdrain. These results are an example of how the regional approach will provide overall greater benefits to the natural resource by taking advantage of the areas that show potential for better infiltration rates, discussed below.

A preliminary soils investigation to assess the infiltration potential of soils in the reuse irrigation was completed in partnership with the RPBCWD. Figure 5 illustrates the general locations of the infiltration testing completed for the purposes of estimating the irrigation rates and volumes that could be applied to the area. Soil sample locations are indicated by the numbered red dots. A full-size figure is provided in Appendix A. Results indicate that potential irrigation rates and volumes may be higher than originally assumed under a HSG C or D soil condition. Rates ranged from essentially zero to as high as 16.1 inches per hour, with many tests in the 0.4 to 2 inch per hour range.



Figure 5. Irrigation Area Soil Test Locations

4.0 ANALYSIS AND RESULTS

Preliminary analysis for regional treatment opportunities involved first defining the projects that could benefit from a regional approach and quantifying the regulatory requirements that would apply for each project. The next step was to evaluate a range of regional stormwater practices, starting with volume control practices as required by the RPBCWD followed by other potential regional treatment practices. The final step was to quantify what level of regulatory credit could be obtained for each of the treatment systems. Plans for selected components of the regional reuse system, including the forcemain and treatment system, have been advanced beyond the concept level to support a grant funding application. Preliminary plans for these components, completed for the grant application, have been included in the report appendix.

The following sections describe the tools used to complete this analysis, the requirements for each project and area, a summary of practices considered and evaluated, and results of the analysis for three potential treatment systems for the project area.

4.1 Evaluation Tools

Several generally accepted pollutant load and stormwater treatment models and tools were used to develop pollutant load and treatment estimates for this preliminary analysis. Pollutant loads generated were based on the regulatory impervious areas calculated from preliminary plans when available or were based on the parcel size for the private development sites.

- A Minimum Impact Design Standards Calculator (MIDS) model was created to determine the pollutant load generated by each proposed and potential improvement project. MIDS assumes standard pollutant concentrations of 54.5 mg/L TSS and 0.3 mg/L TP are present in urban runoff and applies these values to total annual runoff volume in order to determine annual pollutant load. Total annual runoff is a function of the contributing watershed area, watershed imperviousness, pervious hydrologic soils group, pervious land use and historical rainfall data.
- MIDS was used to estimate pollutant removal performance for the reuse and passive filtration systems. It is assumed that all irrigated pollutants are removed. For filtration BMPs, MIDS calculates pollutant removal efficiencies based on specific BMP characteristics. BMPs were modeled with a media depth of 1.5 feet and having a properly designed phosphorous treatment media layer yielding 80% TSS and 69% TP removal efficiency.
- MIDS was used to determine a single-storm volume (abstraction) credit for the irrigation reuse. The abstraction credit is calculated by multiplying the percent of annual watershed runoff used for irrigation, into the 1.1-inch volume of the watershed impervious area. The percent of annual watershed runoff used for irrigation is calculated by dividing the annual irrigation volume by the annual watershed runoff volume.
- Active filtration system pollutant removal was estimated using a simple formula based on annual potential filtered volume, BMP pollutant removal efficiencies, and an adjusted pollutant concentration to account for re-treatment. Adjusted pollutant volumes are reduced by a factor equal to the annual filtered volume over the annual watershed runoff volume.

Each potential BMP combination was evaluated as described above and assigned a volume credit and a total annual TSS and TP removal mass. These volume and annual pollutant removal values are then used as banked credits from which proposed projects can draw to meet their individual volume and/or pollutant removal requirements.

4.2 Regional Project Area Requirements

Evaluating opportunities for regional BMPs in the project area began with reviewing available project data, previous studies, and conducting an initial coordination meeting with District and City staff. The coordination meeting discussed approach to creating a regulatory framework, potential BMP locations, previous study assumptions and results, sharing existing models and background data, and upcoming projects.

As mentioned earlier, the City has identified a number of projects within the study area that have either begun the planning and/or design phases. The first of these projects are expected to complete design and begin construction in early 2024, including the 2024 Street Rehabilitation project and the first phase of work on the Civic Campus.

Because created and banked volume and pollutant load credits are not likely to meet the needs of all anticipated projects, the city has identified a sequence for which the regional credits will be used and created in alignment with when each project will be permitted and constructed. In addition to the use of regional credits, and consistent with District Rules, each project will be expected to evaluate, and implement where feasible and cost-effective, site-specific measures and practices that can reduce the amount of credit used from the regional bank.

24-01 STREET REHABILITATION (PROJECT 1)

The 24-01 Street Rehabilitation project consists of approximately 3 miles of roadway improvements with a mix of full reconstruction and rehabilitation in the residential Chan View neighborhood. The project has 3.7 acres of regulatory impervious surface within Rice Marsh Lake subwatershed. The project is required to meet the linear project criteria of RPBCWD. Recognizing that this project will be the first to use credits, prior to the credits being created, the regional banking credits will be in a deficit.

CIVIC CAMPUS IMPROVEMENTS (PROJECT 2)

The Civic Campus project consists of reconstructing the campus facilities consistent with the layout shown in Figure 4. Impervious areas shown in the concept payout were used to calculate the regulatory impervious area of 4.9 acres for the project. The project is required to meet the development criteria of RPBCWD. This project will also be started prior to the credits being created.

MARKET BOULEVARD RECONSTRUCTION (PROJECT 3)

The Market Boulevard reconstruction project consists of reconstructing the roadway and pedestrian facilities from TH 5 to West 78th Street. There is a potential for the project to extend to the City Hall Campus at Chan View, include a roundabout at 78th Street and result in reconstruction of some portions of 78th Street. The base project up to West 78th Street shown in Figure 3 will reconstruct an estimated 2.6 acres of impervious surface. If the project is extended north of West 78th Street, additional regulatory impervious area will be triggered. The project is required to meet the linear project criteria of RPBCWD.

The project will be a full reconstruct of the roadway along with completing utility work where needed. This creates a unique opportunity to efficiently and cost-effectively route a stormwater force main along the project corridor for a potential reuse system discussed later in this report.

This is the highest priority project for use of credits as there are limited opportunities along the corridor for sufficient surface or subsurface treatment systems that would meet the regulatory requirements. It is also

one of the first projects planned for construction such that the regional reuse system could be constructed concurrently.

PRIVATE REDEVELOPMENT PROJECTS

While there are eight (8) distinct private parcels identified in Figure 7 (see Appendix), the priority of these projects are considered equal and any available volume or pollutant load reduction credits would be allocated on a first-come, first-served basis at the discretion of the City and through consultation with RPBCWD staff. The regulatory impervious areas for the private parcels are based on the full parcel areas.

SUMMARY OF PROJECT REQUIREMENTS

The overall project area regulatory impervious area assumptions for each project are listed in Table 1 along with the applicable RPBCWD regulatory volume and required volume, TSS and TP removal goals.

Table 1. Study Area Project Requirements Summary

Project	Impervious Area (ac)	Regulatory Volume (inch)	Volume Required (CF)	TSS Required (lbs/yr)	TP Required (lbs/yr)
24-01 Street Rehab	3.7	0.55	7,305	1,206	4.4
Civic Campus	4.9	1.1	19,486	1,387	5.1
Market Boulevard	3.6	0.55	7,187	1,203	3.8
Private Parcel A	4.1	1.1	16,502	1,192	4.3
Private Parcel B	3.0	1.1	12,019	868	3.1
Private Parcel C	2.7	1.1	10,734	775	2.8
Private Parcel D	2.3	1.1	9,239	667	2.4
Private Parcel E	5.2	1.1	20,791	1,502	5.4
Private Parcel F	4.2	1.1	16,702	1,207	4.4
Private Parcel G	2.0	1.1	7,829	566	2.0
Private Parcel H	1.6	1.1	6,410	463	1.7

4.3 Abstraction and Treatment Options

Preliminary analyses have been completed for the primary stormwater practices to be used for regulatory credits within this regional framework.

STORMWATER REUSE

From the outset of this analysis, reuse was assumed to be one of the primary regional opportunities to further explore for the downtown area. The previous RPBCWD study identified reuse as an opportunity to use the green space in the Chanhassen Elementary School and City Hall area for irrigation for either local runoff or from the regional wet pond along TH 5. This study builds from that base approach and assume the irrigation water would be from the regional wet pond along TH 5 where there is effectively a continuous source for irrigation water due to the size and volume of the basin.

Based on the methods of evaluating water quality volume and pollutant removal credits discussed in section 4.1, and using an estimated 8.5 acres of available irrigation area, the estimated volume irrigated and pollutant load removals (annual TP and annual TSS) for both a 1-inch per week and 2-inch per week irrigation rate. Supporting preliminary calculations for the reuse system and filter systems have been provided to the

watershed engineer for preliminary review. Updates to these calculations will be submitted with the final plans for the Market Boulevard project.

The reconstruction of Market Boulevard creates an opportunity to cost-effectively install the storm force main for pumping the water from the regional stormwater pond to a cistern or storage tank near the irrigation fields north of City Hall. As shown in Figure 8 (see Appendix), the conceptual alignment for the force main generally follows the west curb line of Market Boulevard for approximately 1,550 lineal feet from the northeast corner of the regional retention basin to the southeast corner of City Center Park. The force main runs at a roughly 10-foot depth and gains 47 feet of elevation from elevation 940 to 987.

Based on the reuse system irrigating public green spaces, we have assumed the system would include a filtration system (membrane or particle) and UV disinfection prior to being used for irrigation of the ball fields, park areas and other landscape areas. Two level of irrigation demand were identified based on the different assumptions in the reuse tools. The lower demand of 37,500 gpd is based on limiting irrigation to no more than 3 times per week. The lower demand value is comparable to the estimated daily irrigation volume the City completed during the years 2009, 2010, 2012 and 2013 for the 4.9 acres of ball fields only. The higher demand assumes irrigation could occur at twice that rate provided the areas to be irrigated are not already saturated.

From a preliminary design standpoint, there are several options that can be explored further as the design advances. In either scenario there is UV disinfection to meet log reduction targets (LRT) per local guidelines and instrumentation for reporting. The base assumption is that the system could be tailored accordingly for indoor or outdoor non-potable reuse. Equipment will be in an enclosed shelter.

Option 1 – Membrane Filtration

- Pros: Membrane provides a robust physical barrier, superior filtration capability, membrane filtration qualifies for LRT credit, more consistent effluent water quality, more future flexibility including it can be converted to a membrane bioreactor process if regulations change or additional treatment is needed due to excessive constituents in the runoff.
- Cons: Slightly larger system (more space required), chemical backwashes, more operator involvement, higher capital cost.
- Option 1A – 37,500 gpd (irrigate 3 days per week)
- Option 1B – 75,000 gpd (irrigate 6 days per week)

Option 2 - Particle Filtration

- Pros: Smaller footprint, lower capital cost, less operator involvement.
- Cons: Variable water quality, less process control flexibility, no physical barrier to prevent particulate from making it through filtration like what a membrane offers.
- Option 2A – 37,500 gpd (irrigate 3 days per week)
- Option 2B – 75,000 gpd (irrigate 6 days per week)

Treatment System Size and Planning Level Cost

Option	Shelter Footprint (SF)	Cost ⁽¹⁾
1A	140	\$430,000
1B	150	\$480,000
2A	120	\$220,000
2B	130	\$260,000

1. Costs are for the treatment system only. Shelter, pump, forcemain, cistern, permitting and design are not included.

FILTRATION OPTIONS

Several filtration system options were evaluated including new basin areas and filtration benches on existing pond areas. Some of the systems evaluated and discarded were:

- TH 5 Pond Filtration Bench – discarded due to elevation constraints that limited the ability to route the filter system tile outlet and existing slopes around the basin would require slopes steeper than 3:1 to add a filter bench in the desired areas.
- Pond East of Market Boulevard – discarded filter bench options for this area due to elevation and routing limitations and due to the area being a wetland mitigation area.
- Market Street Parking Area passive filtration – discarded due to limited contributing drainage area and limited pollutant removals compared to the active filtration alternative for the same location.

Two areas for filter systems were advanced to more detailed evaluations. In all cases, the filter systems are assumed to be iron enhanced or spent lime filters that would achieve a higher level of pollutant removal than a standard sand-compost filter mix. These systems do not provide true volume (abstraction) credit.

- 79th Street Parking Area - Active Filtration BMP. Figure 9 shows the concept for a new filter system graded in the available area along 79th Street. The proposed active filtration system utilizes the space currently occupied by an existing MnDOT filtration basin and additional City right-of-way. The project would expand the existing filtration BMP and create the active (pumped) connection to the regional wet pond. By expanding the existing basin, the City would take over maintenance of the BMP, which would remain functional to treat MnDOT stormwater via the passive existing system.
- Market Street Parking Area - Active Filtration BMP. See Figure 10 for BMP footprint. The active filtration system treats water pumped from the TH 5 regional wet pond and recycles it back to the regional wet pond.

4.4 Recommended Improvements

Recommended regional features include all three of the systems described above including:

- The reuse system for irrigation of City Hall and School fields, with the ability to expand the system for use as irrigation water for 78th Street and future development projects in the area.
- Market Street active filter. This will require discussions with the private landowner to confirm availability of the property and what level of credits may need to be allocated to their planned or future project needs. Depending on the extent of space remaining after the treatment system building is located on the west side of Market Boulevard, this system may accommodate two separate treatment cells, one on each the east and west sides of Market Boulevard.
- 79th Street active filter including expansion to include the MnDOT BMP area. This will require discussions with MnDOT to confirm agreement for use of the area and what level of credits may need to be allocated to the previous MnDOT project.

In addition to the regional practices described in the previous sections, we anticipate that each public or private project may develop smaller scale, individual project practices that offset some of the credit each may

otherwise use from the planned volume and pollutant load banks. These individual site BMPs could be rainwater gardens, above or below ground filter systems, tree trenches, or other systems.

While rate control may be a requirement for each individual project, this was not evaluated as part of this study. None of the projects identified in this study are expected to increase impervious cover so they would not likely result in an increase discharge rate. It is anticipated that rate control analyses would be required for each project at the time they are going through the permitting process, even if they are proposing to use banked regional volume or pollutant removal credits. The City's 24-01 Streets project and the Civic Campus project have submitted rate control analyses as part of their individual permit applications.

5.0 IMPLEMENTATION PLAN

5.1 Watershed District Approval

Section 4 of the RPBCWD stormwater rules addresses the requirements for Regional Stormwater Management. The rule states that a regional plan must provide stormwater management that meets or exceeds the criteria for rate, volume and water quality established in the rule. The regional plan must provide for an annual accounting to the District of treatment capacity created and utilized by projects or land-disturbing activities within the drainage and treatment area to which the plan pertains.

District approval of a regional plan will be based on a determination that:

- a. The use of a regional facility in place of onsite stormwater management is not reasonably likely to result in adverse impacts to local groundwater or natural resources, including, for example, reduced water quality, altered wetland hydrology, changes to stream velocities or base flow, erosion or reduced groundwater recharge; and
- b. The plan incorporates onsite BMPs where necessary to mitigate impacts and provide local benefits not provided by the regional facility.

The framework credit accounting process for this regional stormwater plan was discussed with the Board in a work session meeting on January 25, 2024. The process will include the following steps:

1. The City will submit a permit application for the first project (City Project 24-01 Street Rehabilitation) that proposes to use credits from the regional treatment system bank with a specified level of volume, TSS and TP credits to be used from the bank. The application will include computations and supporting documentation for the estimated amount of credits available based on this report and any updates to the regional BMP design.
2. The City will work with District staff through the review process to define the level of treatment credits the project will use from the bank. The City will complete additional technical analyses and stormwater system design changes required as part of the permit review process. Based on the required changes, if any, the City will provide updates to Table 2 in the regional framework to document the actual credits used from the bank for each project.
3. If applicable, the City and District staff may exempt a project-specific rate control analysis if the project:
 - a. is using regional treatment credits under this plan; and

- b. the project will not result in an increase in impervious area and will not create a higher discharge capacity leaving the site (i.e., not increasing the outlet pipe size). If a project increases impervious or the capacity of an outlet pipe from the project limits, the project will be required to complete a rate control analysis.
4. The Board will take action on the individual permit application.
5. The final regional facility design will be completed and the system will be constructed in conjunction with the Market Boulevard Reconstruction Project scheduled for 2025 construction. With the final design, the City will finalize the credits generated by the regional facility and will account for any prior removals from the bank to determine the balance of credits remaining. Any remaining credits available may be used by the City for future projects or may be made available to developers for purchase. All projects using banked credits shall be located within the subwatershed and are subject to approval by the District.
6. The City will submit an annual report on the amount of credits used in that year and the remaining available credits until all banked credits have been used. The City's annual report will include an assessment of the functionality of the regional BMPs based on irrigation pumping records, regional pond water levels and any testing completed on the BMPs.

5.2 Implementation Framework

The overall goal of establishing an implementation framework is to provide for the structure of what the District needs for annual accounting of treatment capacity created and utilized by projects. The basic structure of the framework is to first confirm the ability to implement one or more of the practices discussed in Section 4 and refine the estimated volume and treatment credits available in each BMP.

The framework will include the estimated regional volume and treatment credits until each BMP is implemented through final design, permitting review and construction. The estimates provided in this study are preliminary and intended to assess the order of magnitude of the benefits and potential credit available relative the project needs in the area.

REGIONAL BMP CREDIT ACCOUNTING

An initial framework for the structure of the accounting for BMP credits created and used is shown in Tables 2A, 2B and 2C. Assuming all three BMPs discussed previously are implemented, the estimated total available credit for each factor (volume, TSS and TP) is recorded in the accounting tables. Table 2A uses an assumed 1.0" per week irrigation depth for the reuse system, Table 2B uses an assumed 1.65" per week irrigation depth and Table 2C uses an assumed 2.0" per week irrigation depth. These depth values represent the maximum irrigated rate, with MIDs calculation also providing an average achieved irrigation rate for each scenario of 0.95", 1.57" and 1.9", respectively. As projects are moving through the permitting process, they are able to request use of available banking credits and the approved credits to be used are entered in the lower half of the table.

As shown in the framework summary tables, it is likely that the first two City projects could use all available volume credit, leaving only TSS and TP credits for use on other projects if the irrigation depth is 1" per week. If the irrigation depth achieved is on the order of 1.65" or 2.0" per week, there would be excess credits for each parameter, TP, TSS and volume. The framework allows for additional BMPs to be added to the extent

they support the overall regional treatment framework and goals. Individual project BMPs such as small raingardens, filtration swales, filter systems, etc. would not be added in the upper half of table 2 as they would be specific to each individual project. These individual site BMPs, would however, reduce the magnitude of credit used by a given project in the lower half of table 2.

The City fully intends to maximize the use of the reuse irrigation system to achieve a level of volume credit approaching the values listed in Table 2C (2" per week), and at a minimum the values listed in Table 2B (1.65" per week). Because the actual level of irrigation volume will not be known until several years of recording the data have been completed, the actual net credits available for the first three projects and potential future projects will not be known. For the purposes of this working regional framework document, the City is requesting the District approve the values listed in Table 2B, using a maximum irrigation rate of 1.65" per week.

The City bases this goal and request, in part, on the historic rate of irrigation conducted on the same irrigation areas dating back to 2009 (see Appendix C for a summary of these data). The city irrigated a depth of approximately 0.7" per week in the year from 2009 to 2013 prior to implementing water conservation measures and upgrading to an automated control system compared to manual operation. Recognizing that the city's goal when using potable municipal water was to use only enough water to support the needs of the vegetation. This opportunity to convert irrigation water to reused stormwater, will allow the city to shift its goal to using as much volume as the land will accept while maintaining the areas in a usable condition for planned and programmed activities. These data indicate that the goal on the order of twice what the pre-conservation irrigation rates were is reasonable when also factoring in the soil test results showing higher infiltration rates than anticipated as discussed in Section 3.5 of this report.

Table 2A. Credit Accounting Framework (1"/week Reuse)

Description	TP (lb/yr)		TSS (lb/yr)		Volume (CF)	
	Created /Used	Balance	Created /Used	Balance	Created /Used	Balance
BMPs Implemented						
A - Reuse - Irrigation System	8.6	8.6	1,571	1,571	19,809	19,809
B – City/MnDOT Active Filter	13.6	22.2	2,872	4,443	0	19,809
C – 79th Street Active Filter	11.1	33.3	2,346	6,789	0	19,809
D – Future BMP						
Total Credits Created	-	33.3	-	6,789	-	19,809
Projects Using Bank						
24-01 Street Rehabilitation	-4.0	29.3	-1,099	5,690	-6,729	13,080
Civic Campus	-5.1	24.2	-1,387	4,303	-19,486	-6,406
Market Boulevard	-3.8	20.4	-1,203	3,100	-7,187	-13,593
Project 4 - TBD						

Table 2B. Credit Accounting Framework (1.65"/week Reuse)

Description	TP (lb/yr)		TSS (lb/yr)		Volume (CF)	
	Created /Used	Balance	Created /Used	Balance	Created /Used	Balance
BMPs Implemented						
A - Reuse - Irrigation System	15.3	15.3	2,784	2,784	33,595	33,595
B – City/MnDOT Active Filter	13.6	28.9	2,872	5,656	0	33,595
C – 79th Street Active Filter	11.1	40.0	2,346	8,002	0	33,595
D – Future BMP						
Total Credits Created	-	40.0	-	8,002	-	33,595
Projects Using Bank						
24-01 Street Rehabilitation	-4.0	36.0	-1,099	6,903	-6,729	26,866
Civic Campus	-5.1	30.9	-1,387	5,516	-19,486	7,380
Market Boulevard	-3.8	27.1	-1,203	4,313	-7,187	193
Project 4 - TBD						

Table 2C. Credit Accounting Framework (2"/week Reuse)

Description	TP (lb/yr)		TSS (lb/yr)		Volume (CF)	
	Created /Used	Balance	Created /Used	Balance	Created /Used	Balance
BMPs Implemented						
A - Reuse - Irrigation System	17.8	17.8	3,230	3,230	40,992	40,992
B – City/MnDOT Active Filter	13.6	31.4	2,872	6,102	0	40,992
C – 79th Street Active Filter	11.1	42.5	2,346	8,448	0	40,992
D – Future BMP						
Total Credits Created	-	42.5	-	8,448	-	40,992
Projects Using Bank						
24-01 Street Rehabilitation	-4.0	38.5	-1,099	7,349	-6,729	34,263
Civic Campus	-5.1	33.4	-1,387	5,962	-19,486	14,777
Market Boulevard	-3.8	29.6	-1,203	4,759	-7,187	7,590
Project 4 - TBD						

6.0 CONCLUSION

The City of Chanhassen is committed to completing the projects described in this framework report. The City will fund and construct the regional facilities identified in this framework in conjunction with the Market Boulevard and Civic Campus projects and be responsible for long-term operation and maintenance of the systems. The City may pursue additional funding from available grant programs.

The City recognizes that this is the first regional treatment project that would be permitted by the District and that there are items that will require ongoing coordination and review as the permitting process proceeds and as we learn from the operation of the reuse and active filter systems. The City's goal is to optimize and maximize the stormwater treatment capacity for this challenging area and is seeking partnership and flexibility from the District to execute a regional treatment facility that will have a significant positive long-term impact on the local water resources. The City is excited that this approach provides benefits on multiple levels (surface water quality, potable water conservation and educational opportunities) and represents a strategic approach to water resources management.

APPENDIX A – FIGURES

K:\TWC_Civil\City\CHANHASSEN\MARKET BOULEVARD\CAD\Plan Sheets\Layouts\MarketBlvd-Proposed Geometry Layout.dwg February 08, 2024 - 4:29pm

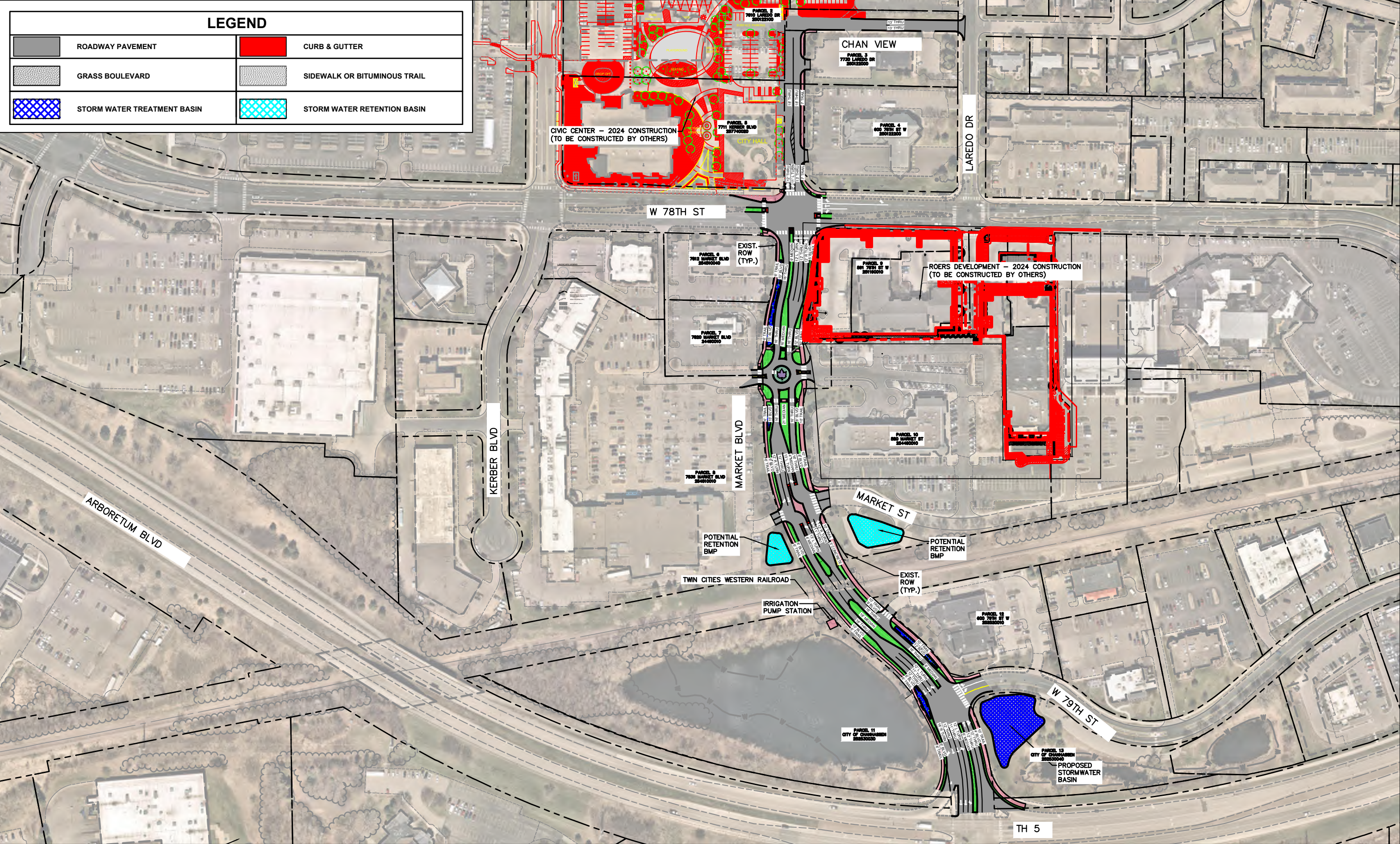

LEGEND			
	ROADWAY PAVEMENT		CURB & GUTTER
	GRASS BOULEVARD		SIDEWALK OR BITUMINOUS TRAIL
	STORM WATER TREATMENT BASIN		STORM WATER RETENTION BASIN

MARKET BOULEVARD IMPROVEMENTS

FIGURE 3 - MARKET BOULEVARD IMPROVEMENTS PRELIMINARY LAYOUT

February 2024



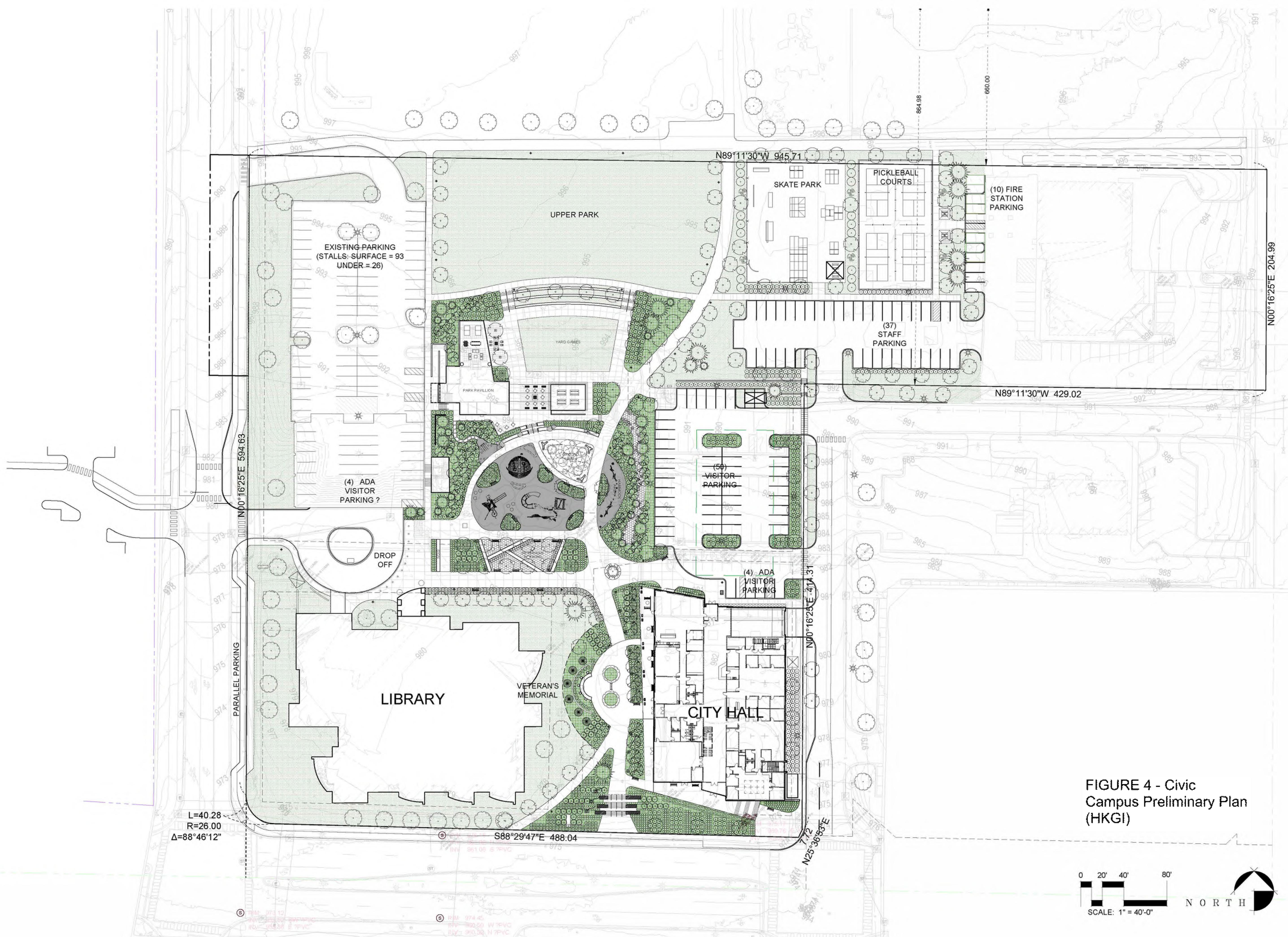
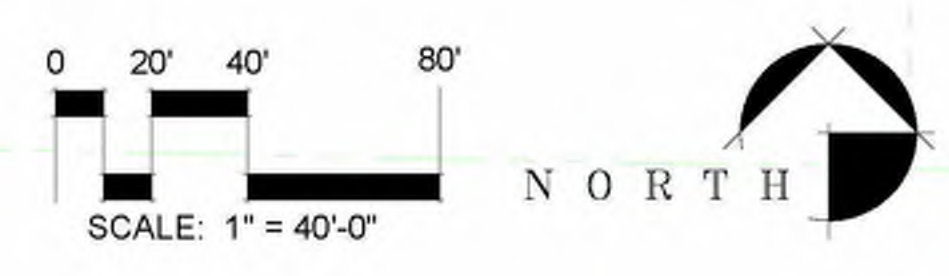

FIGURE 4 - Civic Campus Preliminary Plan (HKGI)



K:\TWC_Civil\City\CHANHASSEN\MARKET BOULEVARD\CAD\Plan Sheets\Exhibits\07102023_Market_Bld-IrrigationInvestigation\Exhibit.dwg August 28, 2023 - 11:57am







IRRIGATION AREA

CITY OF CHANHASSEN:
2.5 AC

IND SCHOOL DIST 112:
4.9 AC

Legend

Soil Sample pts		Each soil sample pt has or will have its own infiltration testing performed at that specific point. If soil sample points are within one of the polygons listed to the left, those points make up soil subsample points of a composite sample (ex: ChanDTSW5 contains three points where soil subsamples were taken to make a composite sample). All soil samples were analyzed by Cornell University's Soils Lab.
ChanDTSW5		
ChanDTSW6		
ChanDTSW7		

K:\TWC_Civil\City\CHANHASSEN\MARKET BOULEVARD\CAD\Plan Sheets\Exhibits\03082024_Market_Bld-IrrigationExhibit.dwg March 08, 2024 - 9:40am

IRRIGATION AREA

CITY OF CHANHASSEN:
2.5 AC

IND SCHOOL DIST 112:
4.9 AC

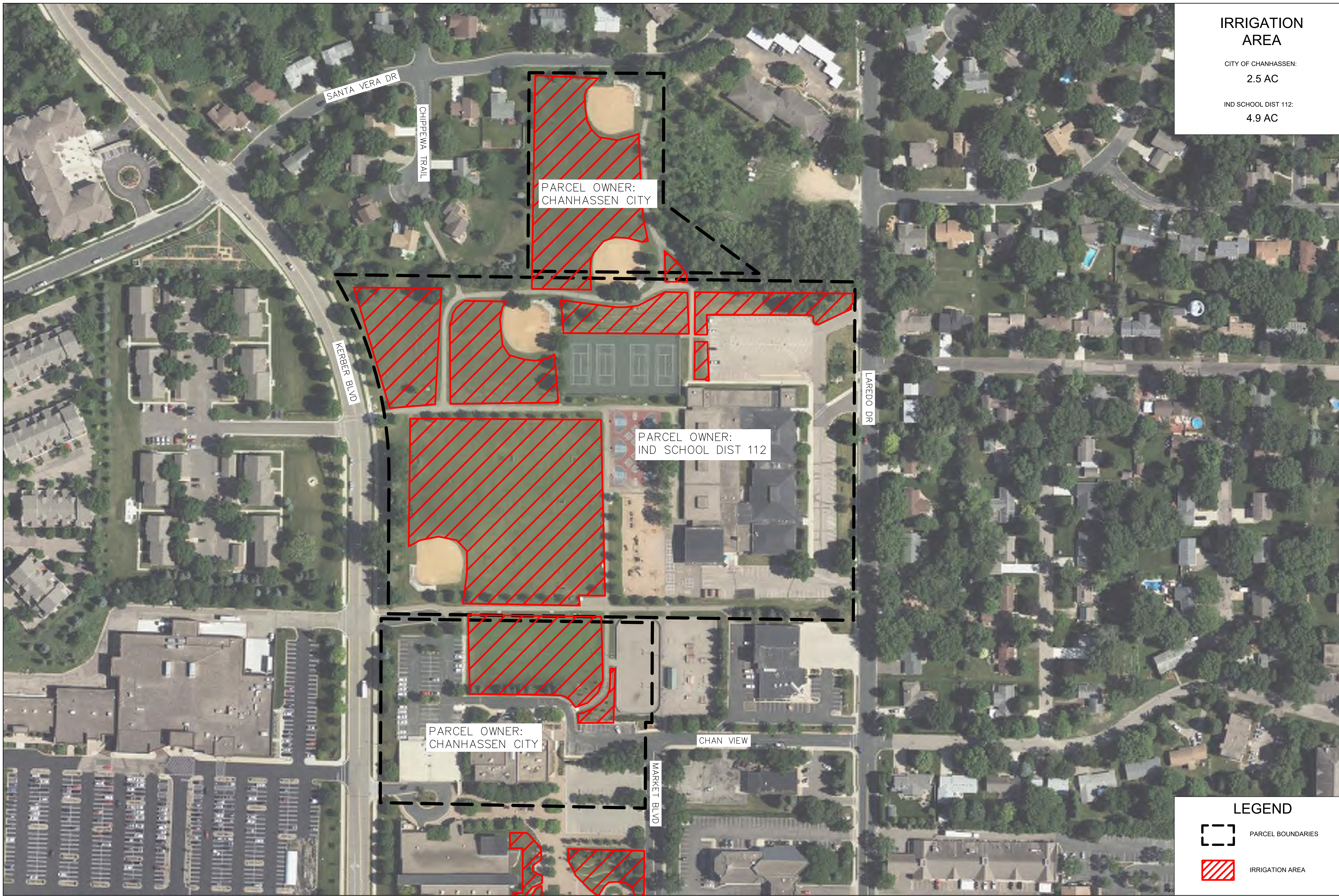



PARCEL OWNER:
CHANHASSEN CITY

PARCEL OWNER:
IND SCHOOL DIST 112

PARCEL OWNER:
CHANHASSEN CITY

LEGEND

-  PARCEL BOUNDARIES
-  IRRIGATION AREA

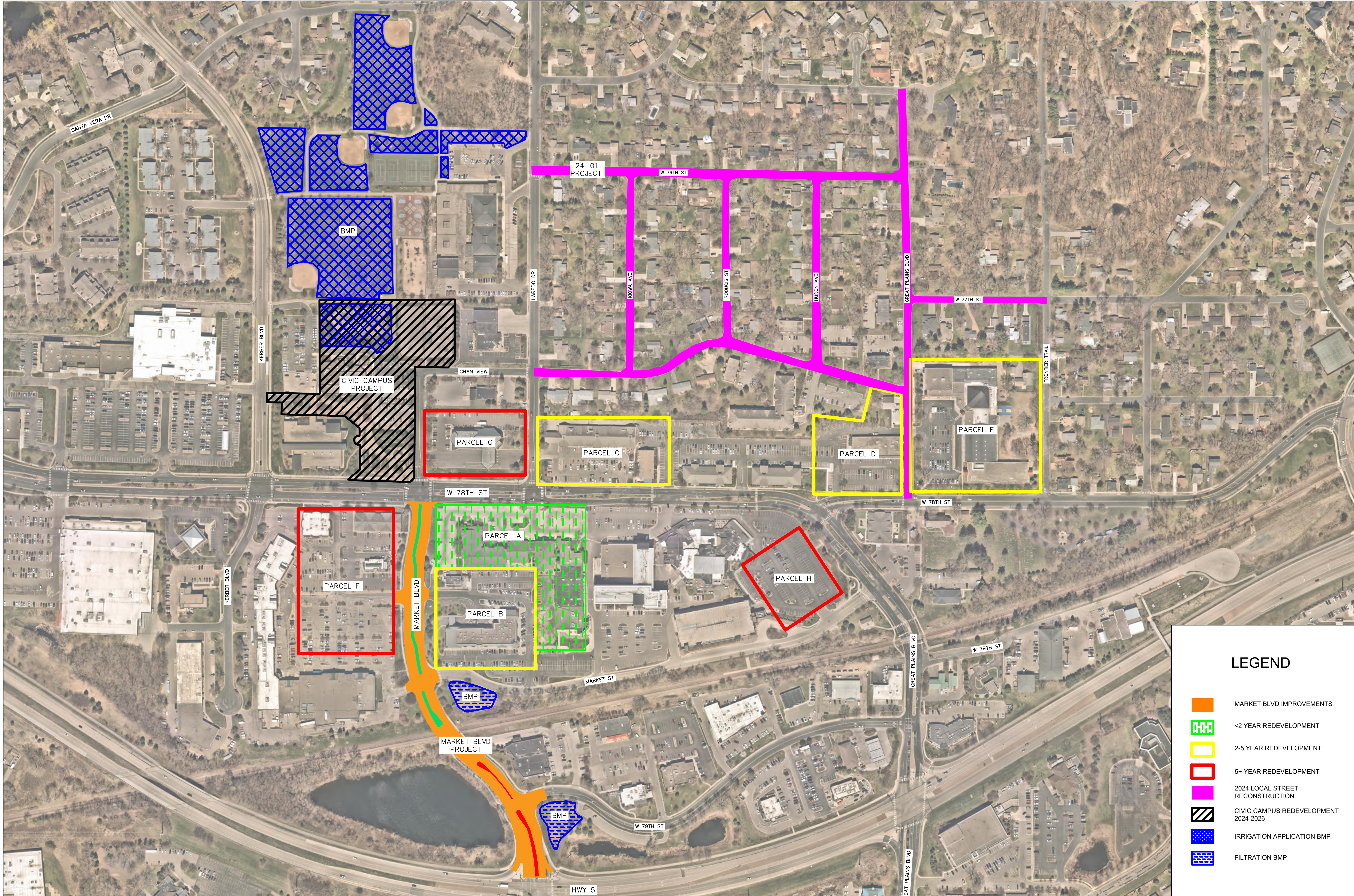

LEGEND

-  MARKET BLVD IMPROVEMENTS
-  <2 YEAR REDEVELOPMENT
-  2-5 YEAR REDEVELOPMENT
-  5+ YEAR REDEVELOPMENT
-  2024 LOCAL STREET RECONSTRUCTION
-  CIVIC CAMPUS REDEVELOPMENT 2024-2026
-  IRRIGATION APPLICATION BMP
-  FILTRATION BMP

K:\TWC_Civil\Civil\CHANHASSEN\MARKET BOULEVARD\DESIGN\BRAINAGE\Stormwater_Study\CAD\MTOPD.dwg March 08, 2024 - 8:27am

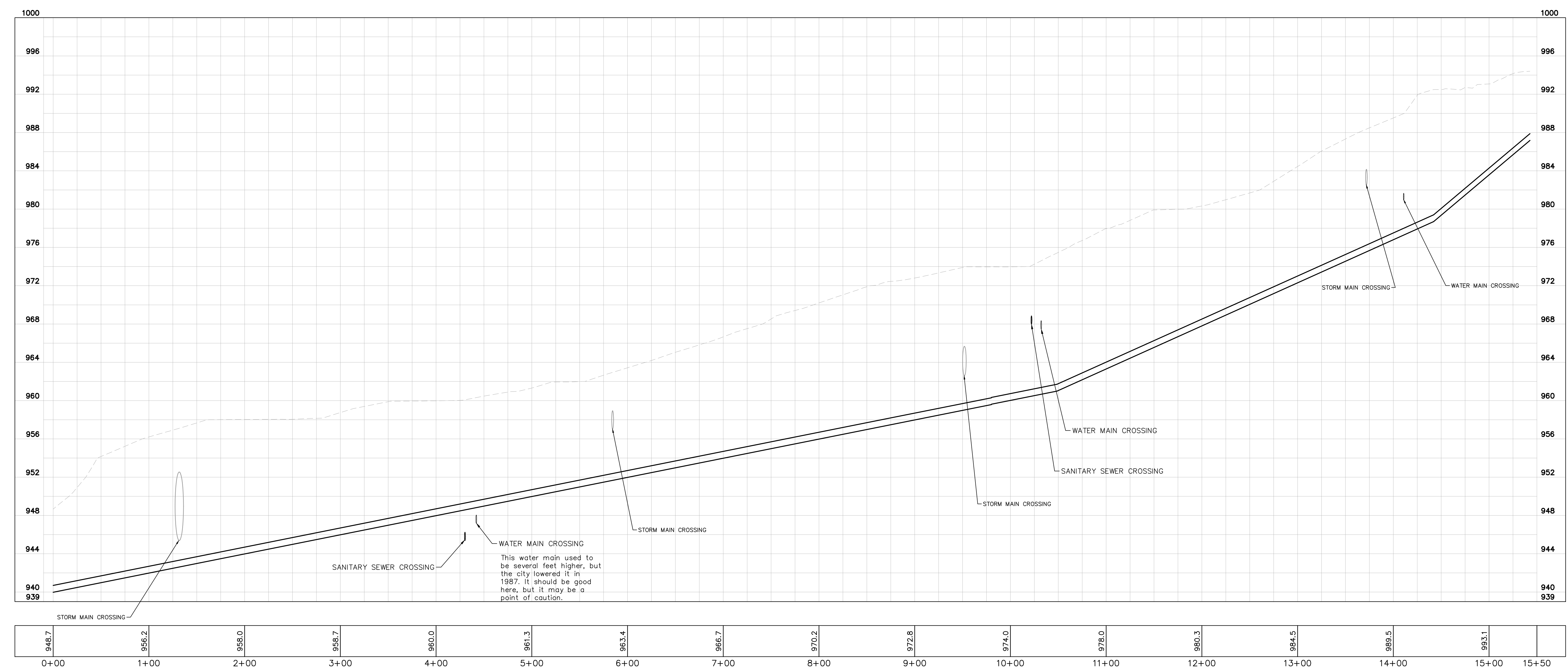

LEGEND

- ▶— PROPOSED FORCE MAIN
- EXIST. STORM SEWER
- EXIST. WATER MAIN
- EXIST. WATER LATERAL
- EXIST. SANITARY SEWER
- PARCELS

K:\TWC_Civil\City\CHANHASSEN\MARKET BOULEVARD\CAD\Plan Sheets\Exhibits\03082024_Market_Bldv-FitBasinExhibit.dwg March 08, 2024 - 9:49am









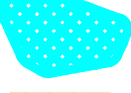

RM_5
DETENTION
POND

W 79TH ST

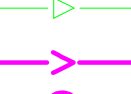
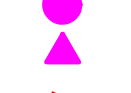
MARKET BLVD

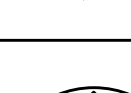
T.H. 5

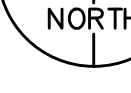
LEGEND

-  PARCEL BOUNDARIES
-  PROPOSED FILTRATION BASIN
-  MARKET BLVD DRAINAGE AREA
-  PARKING LOT DRAINAGE AREA
-  EXISTING WATER MAIN
-  EXISTING SANITARY SEWER
-  PROPOSED STORM INLET
-  PROPOSED F.E.S.
-  EXISTING STORM SEWER
-  EXISTING STORM INLET
-  FLOW DIRECTION ARROW

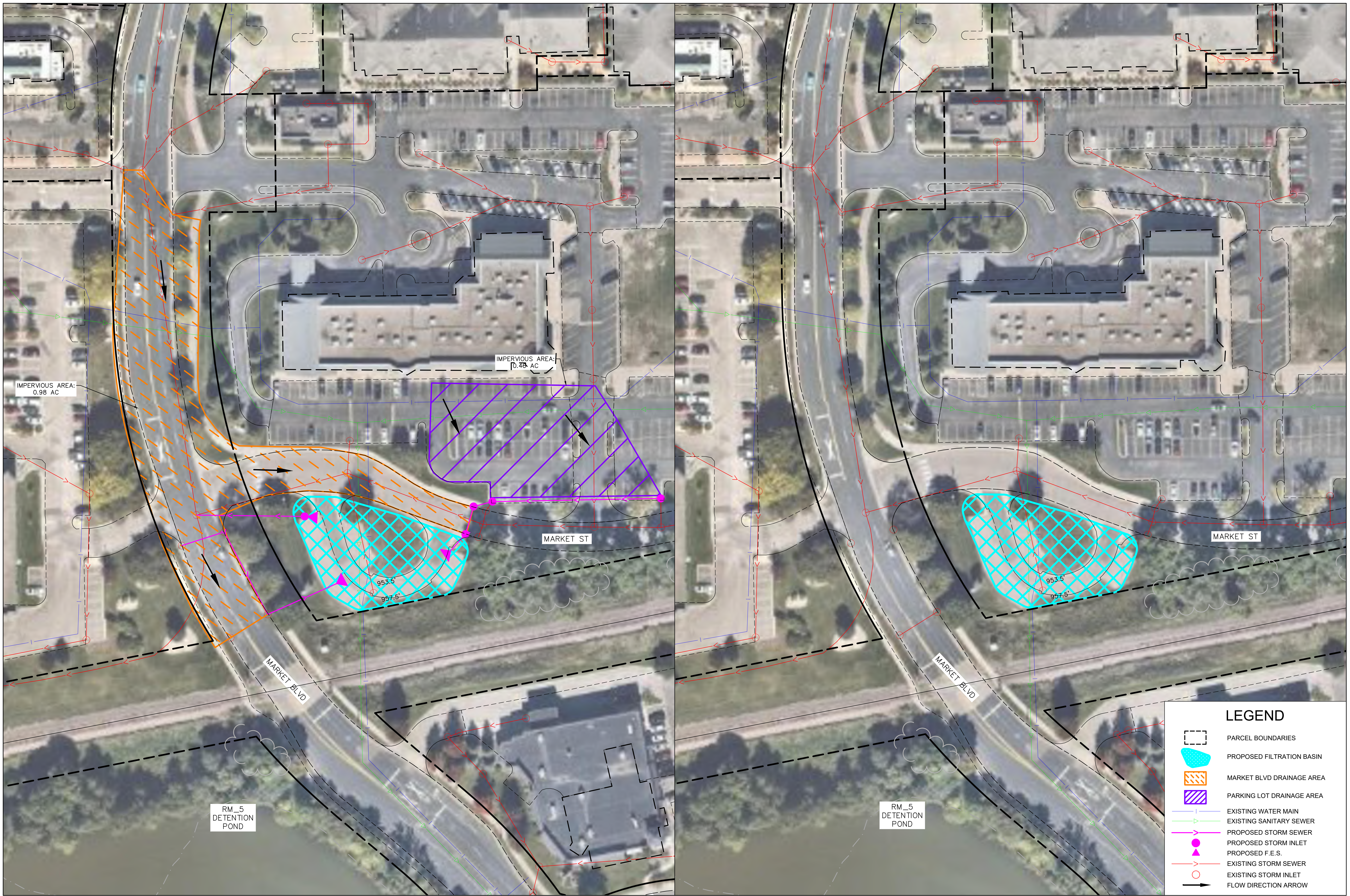

LEGEND

- PARCEL BOUNDARIES
- PROPOSED FILTRATION BASIN
- MARKET BLVD DRAINAGE AREA
- PARKING LOT DRAINAGE AREA
- EXISTING WATER MAIN
- EXISTING SANITARY SEWER
- PROPOSED STORM INLET
- PROPOSED F.E.S.
- EXISTING STORM INLET
- EXISTING STORM SEWER
- EXISTING STORM INLET
- FLOW DIRECTION ARROW

APPENDIX B – SOIL TESTING SUMMARY

ChanDTSW_2023 - 2023 - Chanhassen DT City Center

K_{sat} best-fit site average: 44 mm/hr or 1.71 in/hr

GPS Infiltration Test Site Map



Map Pin #	Test #	Test Name	Ksat (mm/hr)	Ksat (in/hr)	C (mm)	RMS Error of Regression (s)	Normalized RMS
1	25254	ChanDTSW1	23	0.894	-303.7	26	0.4%
2	25255	ChanDTSW1	10	0.405	-366.2	36	0.3%
3	25256	ChanDTSW1	35	1.38	-195.7	34	0.7%
4	25257	ChanDTSW2	176	6.95	-25.6	23	1.2%
5	25258	ChanDTSW2	310	12.2	-27.1	15.5	1.6%
6	25259	ChanDTSW2	409	16.1	-1.7	18.1	1.9%
7	25260	ChanDTSW3	11	0.434	13.5	249	1.5%
8	25261	ChanDTSW3	28	1.10	-59.8	82	0.8%
9	25262	ChanDTSW3	11	0.425	-156.5	91	0.5%
0	25308	ChanDTSW4	NULL	NULL	NULL	NULL	NULL
1	25309	ChanDTSW4	NULL	NULL	NULL	NULL	NULL

Map Pin #	Test #	Test Name	Ksat (mm/hr)	Ksat (in/hr)	C (mm)	RMS Error of Regression (s)	Normalized RMS
2	25310	ChanDTSW4	NULL	NULL	NULL	NULL	NULL
3	25311	ChanDTSW4 2	0.16	0.006	-104,492.4	528	20%
4	25312	ChanDTSW4 2	NULL	NULL	NULL	NULL	NULL
5	25313	ChanDTSW4 2	NULL	NULL	NULL	NULL	NULL
6	25314	ChanDTSW7 2	5.2	0.204	-221.3	194	1.0%
7	25315	ChanDTSW7 2	NULL	NULL	NULL	NULL	NULL
8	25316	ChanDTSW7 2	NULL	NULL	NULL	NULL	NULL
9	25317	ChanDTSW7 1	59	2.31	22.7	55	0.6%
0	25318	ChanDTSW7 1	16	0.616	-478.0	52	0.9%
1	25319	ChanDTSW7 1	72	2.82	-96.9	17.8	0.5%

** NULL tests were removed from the site average calculation

ChanDTSW_2023 - 2023 - Chanhassen DT City Center

This report summarizes the results of a set of Modified Philip Dunne (MPD) Infiltrometer tests performed at the above referenced site. RPBCWD personnel performed the field tests. The software used to compute saturated hydraulic conductivity (K_{sat}) and generate this report assumes that the field personnel used infiltrmeters manufactured by Upstream Technologies Inc. and followed the procedures outlined in "Manual – Modified Philip - Dunne Infiltrometer" by Ahmed, Gulliver, and Nieber.

The following paragraphs describe the individual tests, input values used in the analysis, and methods used to compute the K_{sat} value.

After individual K_{sat} values were calculated, the method used to determine the overall site K_{sat} value ($K_{best-fit}$) is described in "Effective Saturated Hydraulic Conductivity of an Infiltration-Based Stormwater Control Measure" by Weiss and Gulliver 2015, "A relationship to more consistently and accurately predict the best-fit value of saturated hydraulic conductivity used a weighted sum of 0.32 times the arithmetic mean and 0.68 times the geometric mean."

METHOD USED TO COMPUTE K_{sat}

The MPD Infiltrometer software uses the following procedure described in "The Comparison of Infiltration Devices and Modification of the Philip-Dunne Permeameter for the Assessment of Rain Gardens" by Rebecca Nestigen, University of Minnesota, November 2007.

The steps are as follows:

1. For each measurement of head, use the following equation to find the corresponding distance to the sharp wetting front.

$$[H_0 - H(t)]r_1^2 = \frac{\theta_1 - \theta_2}{3} [2\{R(t)\}^3 + 3\{R(t)\}^2 L_{max} - L_{max}^3 - 4r_0^3]$$

2. Estimate the change in head with respect to time and the change in wetting front distance with respect to time by using the backward difference for all values of $R(t)$ equal to or greater than the distance

$$\sqrt{r_1^2 + L_{max}^2}$$

3. Make initial guesses for K and C .

4. Solve the following equations for $\Delta P(t)$ at each incremental value of t .

$$\Delta P(t) = \frac{\pi^2}{8} \left\{ \theta_1 - \theta_0 \frac{[R(t)]^2 + \{R(t)\}L_{max}}{K} \frac{dr}{dt} - 2r_0^2 \right\} \frac{\ln \left[\frac{R(t)[r_0 + L_{max}]}{r_0[R(t) + L_{max}]} \right]}{L_{max}}$$

$$\Delta P(t) = C - H(t) - L_{max} + \frac{L_{max}}{K} \frac{dh}{dt}$$

5. Minimize the absolute difference between the two solutions found in Step 4 by adjusting the values of K and C .

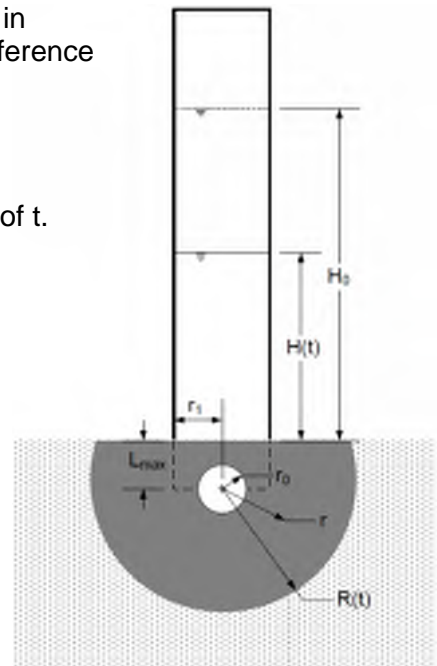

Parameters for Equations

Θ_0 = volumetric water content of soil before MPD test

Θ_1 = volumetric water content of soil after MPD test